

VL-ST60 Product Specifications

Parameter	Value	Units	
Configuration & Physical Parameters			
Motor	Animatics SmartMotors Size 23	-	
Coupling	Beam	-	
Ball Screw Leads	6, 12	mm/rev	
Position Sensors	consult factory	-	
Stroke Lengths	50-600mm in 50mm steps + 700mm	mm	
Overall Length	Stroke + 156 + motor	mm	
Over-Travel	Approx 10	mm	
Unit Mass	1.3349 + (stroke, mm)*0.0039	kg	
Performance			
Unidirectional Repeatability	20	µm	
Bi-directional Reapeatability	40	µm	
Accuracy	0.021/300	mm/mm	
Max Velocity	250 -1000 (stroke dependant)	mm/s	
Max Acceration	0.3	G	
Leads	6	12	mm/rev
Payload Mass	13	10	kg
Rated Velocity	200	400	mm/s
Lifetime*	15000	hr	
Load Rating, Dynamic* (Static)			
Max Continuous Thrust	491	245	N
Max Peak Thrust	788	394	N
M.a, Carriage Moment	11.47 (58)	9 (58)	N*m
M.b, Carriage Moment	3.57 (25)	2.75 (25)	N*m
M.b, Carriage Moment	3.57 (25)	2.75 (25)	N*m

* Based on operating at an average speed of the rated velocity at the given payload. The Lifetime will be significantly reduced operating above the Rated Velocity and/or given payload

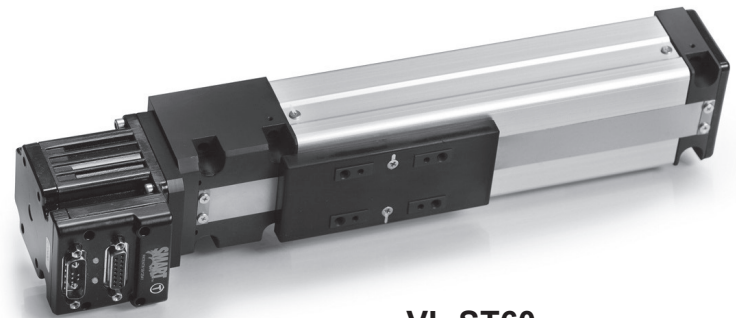

VL-ST60

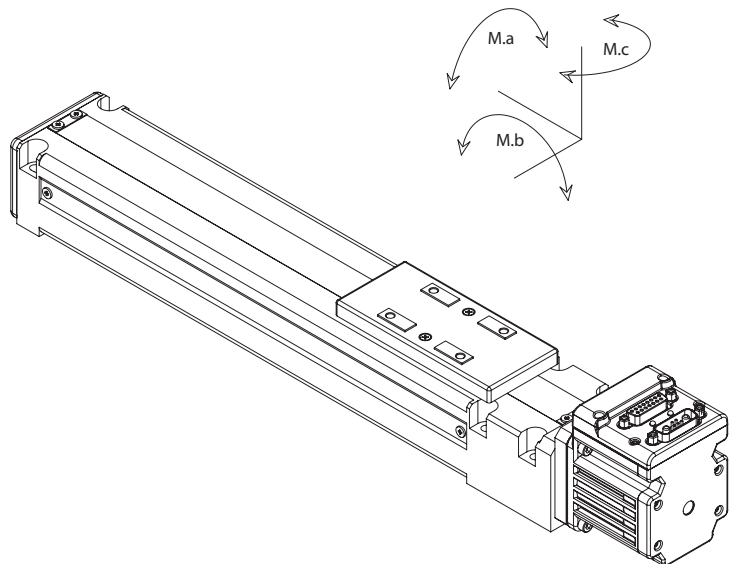

WARNING: Do not exceed these limits

VL-ST60 - Maximum Permissible Carriage Velocity

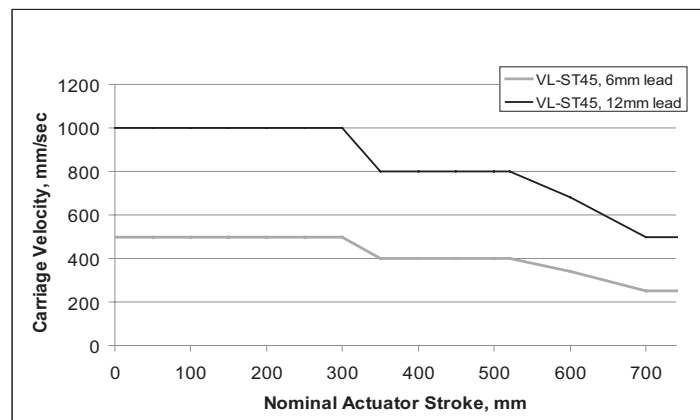

VL-ST series - Maximum Permissible Screw Speed

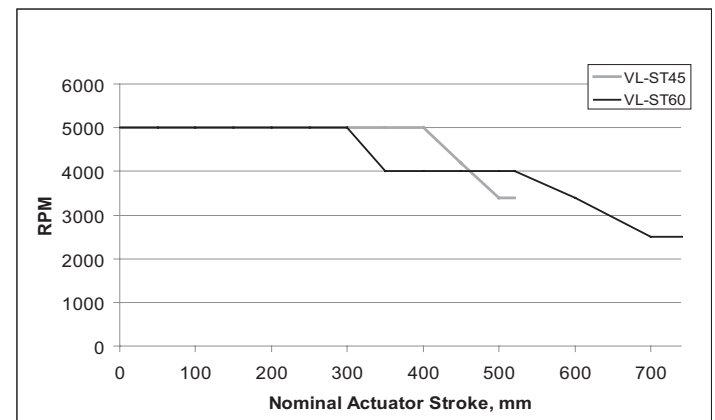

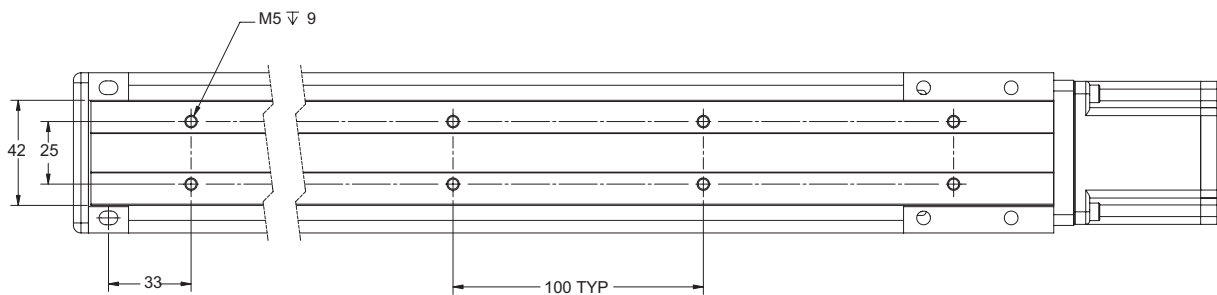
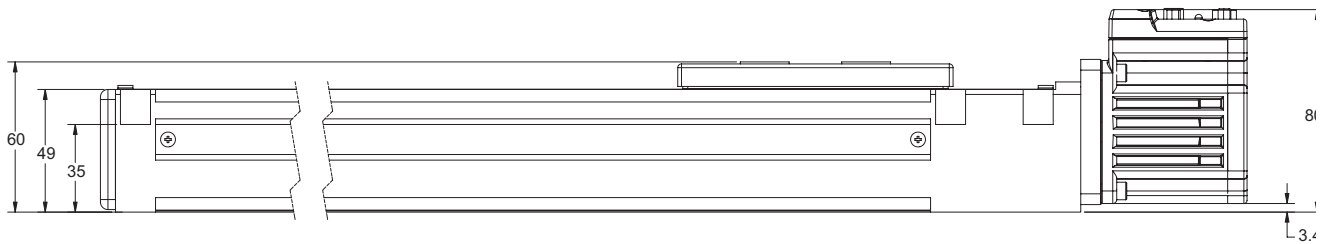
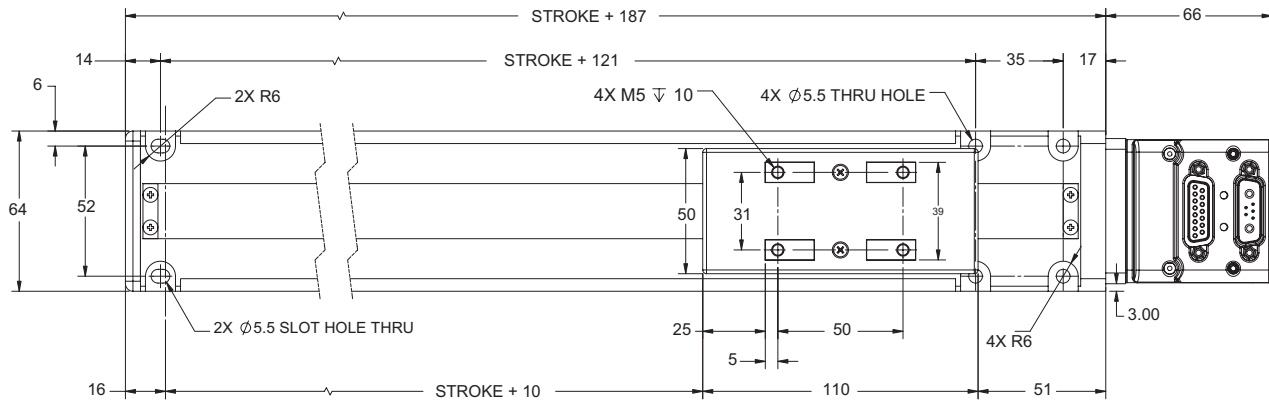

Dimensions in millimeters

Note: For part numbers please refer to our Website at www.oemynamics.com

Thrust Curve performance data in following section on pages 109-126.