

REV.	DESCRIPTION	ZONE	ECO	DATE	APPROVED
0	Initial release				MT
1	Add 5mm to length of flange for new coupling. Add rod end details.	B3	10503	1-28-09	GS

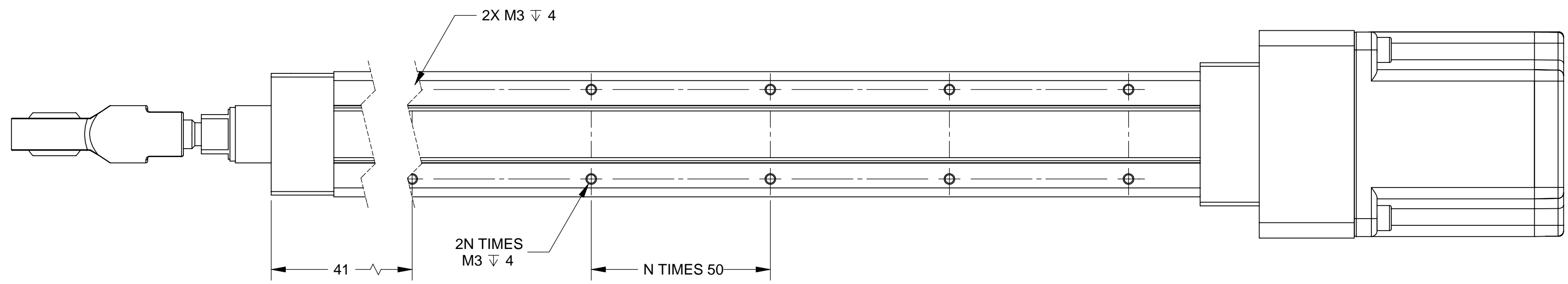
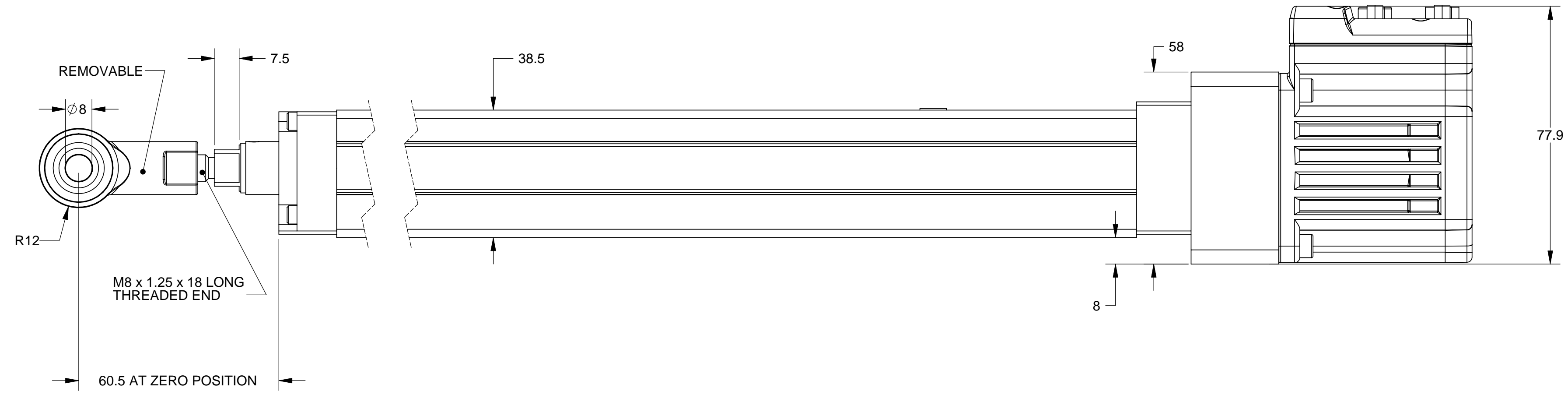
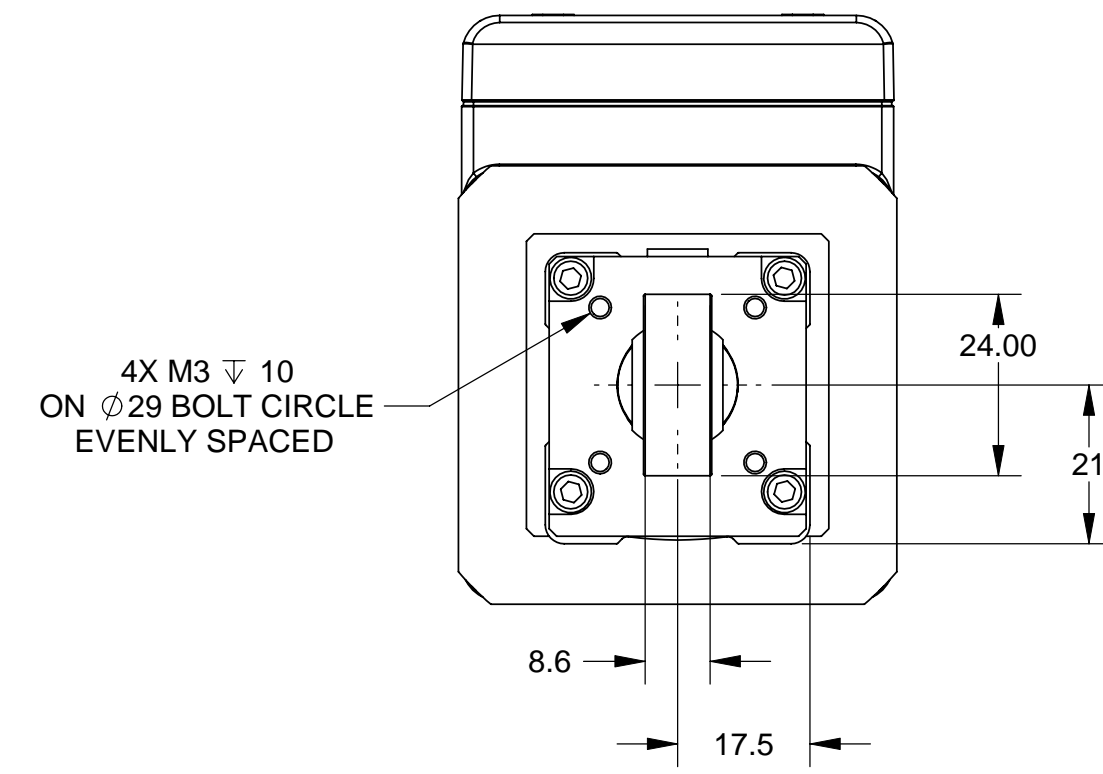
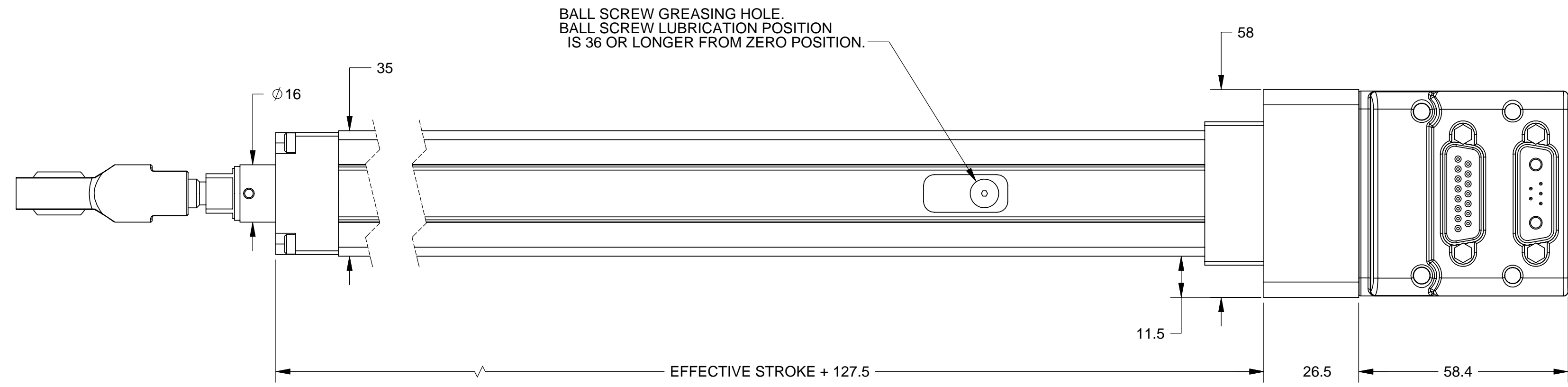

THIS DOCUMENT AND ENTIRE INFORMATION HEREON ARE PROPRIETARY TO OEM DYNAMICS AND SHALL NOT BE USED IN ANY WAY DETRIMENTAL TO OEM DYNAMICS INTEREST NOR REPRODUCED WHATSOEVER WITHOUT EXPRESS CONSENT		DRAWN M.TRAN DATE 2/11/08		California, USA www.OEMDynamics.com	
MATERIAL /	FINISH /	ENGR M.TRAN	DATE 2/11/08	TITLE SPECIFICATION DRAWING VL-CT35	
<b>METRIC</b> THIRD ANGLE PROJECTION UNLESS OTHERWISE SPECIFIED: DIMENSIONS ARE MILLIMETERS AND TOLERANCES ARE: DECIMALS: .XX ± NA .XX ± NA <sup>-</sup> ANGLES: .X ± NA .X ± NA <sup>-</sup> INTERPRET DIMENSIONS AND TOLERANCES PER ASME Y14.5M - 1994. ALL DIMENSIONS, TOLERANCES AND ROUGHNESS APPLY AFTER FINISHING, WHEN APPLICABLE. NO BURRS ALLOWED. BREAK SHARP EDGES 3 MAX. SURFACE ROUGHNESS Ra 0.8 MICROMETERS.		SIZE D DWG NO VLCT35-XXXX-XXXX-XXX-XXXXX4X REV 1 DO NOT SCALE DRAWING SCALE 1:1 SHEET 1 OF 1			