

The Class 6 Industrial Ethernet SmartMotor™, which is available in both standard servo (shown) and hybrid servo versions, represents the next step in the evolution of the SmartMotor integrated motor design. The Class 6 motor lineup includes PROFINET®, EtherCAT® and EtherNet/IP™ versions.

These motors are designed for maximum performance and connectivity. They incorporate a high-end, high-speed processor for exceptional performance, data update rates are as fast as 1 millisecond. There are dual industrial Ethernet ports onboard (no hub or switch required), as well as connections for RS-485 and USB. Additionally, they provide plenty of I/O, with the option to add more through an external expander, for easy integration into any system.



Key Features and Benefits

- Simplify wiring, reduce cost through the onboard dual-port Ethernet switch
- Optionally program, configure and get live diagnostics through the USB interface
- Optionally communicate with the motor through the RS-485 half-duplex port, which provides access as a Modbus Remote Terminal Unit (RTU) Slave
- Easily access SmartMotor programmable autonomous control features in slave mode, which allows special user-programmed functions
 - Reduce limit switch wiring and PLC programming through adaptable distributed control
 - Accurately capture position for high-speed registration applications
 - Quickly reduce costs and improve reliability through use of programmable homing and limits
 - Precisely define motion profiles with local cam execution
 - Easy configuration and status monitoring of Industrial Ethernet and field buses
 - Actively monitor/troubleshoot each motor through local error reporting and diagnostic codes
- Local/standalone benefits (see manual for details):
 - Simplify programming and calculate 32-bit precision motion parameters on the fly with floating-point math and trigonometric functions
 - Govern a move by running it on top of a gearing or camming relationship using the dual trajectory generators
 - Create precise spooling/winding shapes and control tension through advanced gearing (supports preset traverse/take-up parameters)
 - Create complex patterns through advanced camming (with cubic spline interpolation and dynamic frequency/amplitude)
 - Highly configurable local I/O for motion control and general-purpose use in user programs:
 - Drive enable input, fault output, travel limits, registration and position capture
 - External encoder input supporting A-quad-B or Step-and-Direction
 - Total of 7 configurable inputs
 - High-current outputs with external brake-control function



Class 6 EtherCAT® Fieldbus

Industry standard CiA 402 motion profile supports:

- PP, PV, HM, TQ, CSP, CSV, and CST modes
- Dynamic mapping of process data objects (cyclic data exchanges)
- Real time coordinated control using Distributed Clock (DC)



Class 6 PROFINET® Fieldbus

- PROFINET RTC - Real Time Cyclic transfers
- Class 1 and 2 (certified) - unsynchronized
- Class 3 (certification pending) - synchronized SmartMotor clocks
- PROFINET RTA – Real Time Acyclic protocol
- DCP, LLDP, SNMP, MIB-II, and LLDP MIB support



Class 6 EtherNet/IP™ Fieldbus

Easily integrates as a position controller (10 h) device, for:

- Access to unique SmartMotor commands and parameters
- Improved uptime with optional redundant cabling through Device Level Ring (DLR)
- Optimal performance ensured through Quality of Service (QoS)
- Simplified, modular programming through Add On Instructions (AOI)
- Direct access to SmartMotor native commands and parameters through TCP/IP

Overview

Software

C5 D-Style

C5 M-Style

C6 M-Style

C6 Low-Cost

Cables, Etc.

Actuators

Gearheads

Power Supplies

Overview

Software

C5 D-Style

C5 M-Style

C6 M-Style

C6 Low-Cost

Cables, Etc.

Actuators

Gearheads

Power Supplies

| SmartMotor™ Series | SM23166MT-EXX | |
|-------------------------------|---------------|------------------------------------|
| Continuous Torque at 48 volts | 68 | oz-in |
| | 0.48 | N-m |
| Peak Torque | 128 | oz-in |
| | 0.90 | N-m |
| Nominal Continuous Power | 189 | watts |
| Nominal Peak Power | 213 | watts |
| No Load Speed | 4,700 | rpm |
| Voltage Constant | 9.08 | V/kRPM |
| Winding Resistance | 0.7 | Ohms |
| Encoder Resolution | 4,000 | counts/rev |
| Rotor Inertia | 0.00103 | oz-in-sec ² |
| | 7.27 | 10 ⁻⁶ kg-m ² |
| Weight | 1.7 | lb |
| | 0.77 | kg |
| Shaft Diameter | .375 | in |
| | 9.53 | mm |
| Shaft, Radial Load | 15.0 | lb |
| | 6.80 | kg |
| Shaft, Axial Thrust Load | 3.00 | lb |
| | 1.36 | kg |
| EtherCAT Available | Yes | |
| PROFINET Available | Yes | |
| EtherNet/IP Available | Yes | |

SM23166MT-EXX



Maximum temperature: 85°C at electronics, 130°C at windings.
 Recommended ambient temperature range: 0°C – 50°C.
 Storage temperature range: -10°C – 85°C.
 Relative humidity: maximum 90%, noncondensing.

| SmartMotor™ Series | SM23216MH-EXX | |
|-------------------------------|---------------|------------------------------------|
| Continuous Torque at 48 volts | 165 | oz-in |
| | 1.17 | N-m |
| Peak Torque | 300 | oz-in |
| | 2.12 | N-m |
| Nominal Continuous Power | 60 | watts |
| Nominal Peak Power | 115 | watts |
| No Load Speed | 2,250 | rpm |
| Encoder Resolution | 4,000 | counts/rev |
| Rotor Inertia | 0.0065 | oz-in-sec ² |
| | 4.59 | 10 ⁻⁵ kg-m ² |
| Weight | 2.79 | lb |
| | 1.27 | kg |
| Shaft Diameter | .375 | in |
| | 9.53 | mm |
| Shaft, Radial Load | 16.86 | lb |
| | 7.65 | kg |
| Shaft, Axial Thrust Load | 3.37 | lb |
| | 1.53 | kg |
| EtherCAT Available | Yes | |
| PROFINET Available | Yes | |
| EtherNet/IP Available | Yes | |

SM23216MH-EXX



Maximum temperature: 85°C at electronics, 130°C at windings.
 Recommended ambient temperature range: 0°C – 50°C.
 Storage temperature range: -10°C – 85°C.
 Relative humidity: maximum 90%, noncondensing.

*For other data, please consult the factory.

SM23166MT-EXX Torque Curves

SM23166MT-EXX motor Torque vs. Speed, 48 volts, MDE commutation, 25°C ambient (curves are derated at higher ambient)

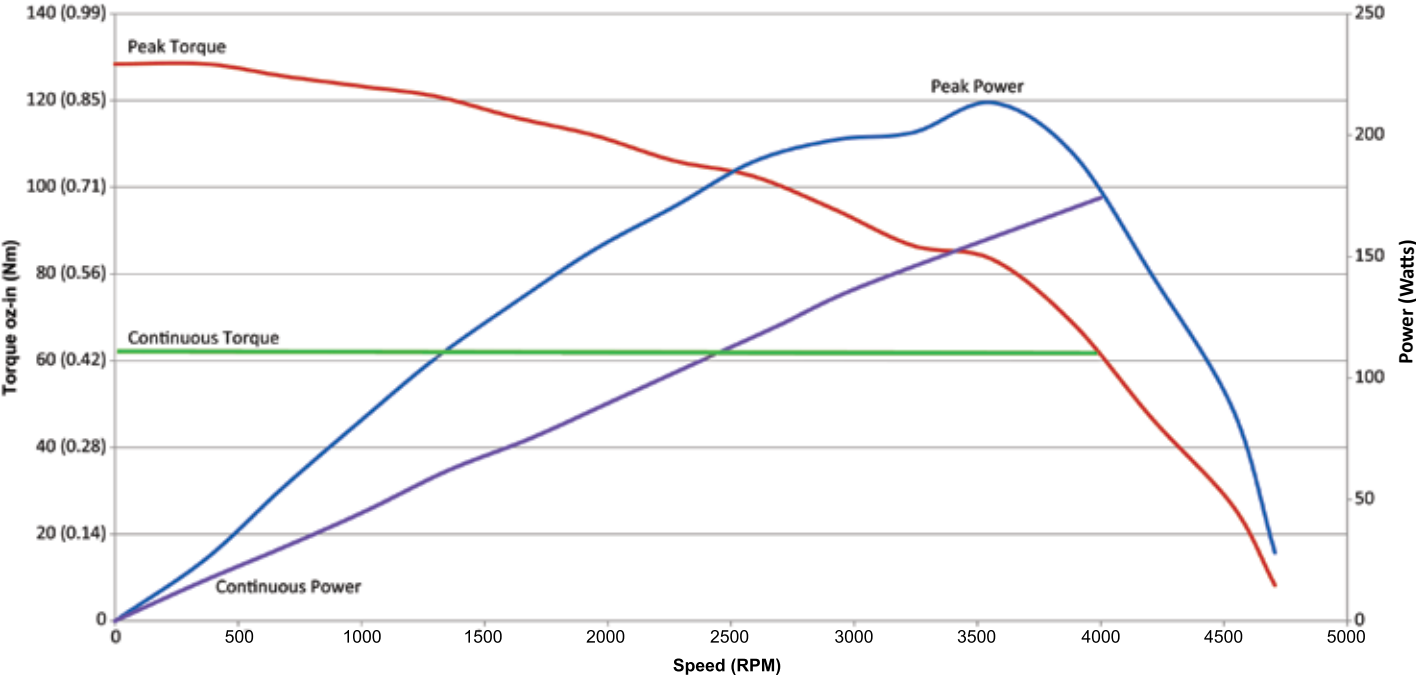

Continuous rating based on 25°C ambient temperature, motor mounted to a 6x6x¼ inch aluminum heat sink, and electronics/windings below maximum temperature. Peak torque is available for 3 seconds at a 10% duty cycle.

SM23216MH-EXX Torque Curves

SM23216MH-EXX motor Torque vs. Speed, 48 volts, MDC commutation, 25°C ambient (curves are derated at higher ambient)

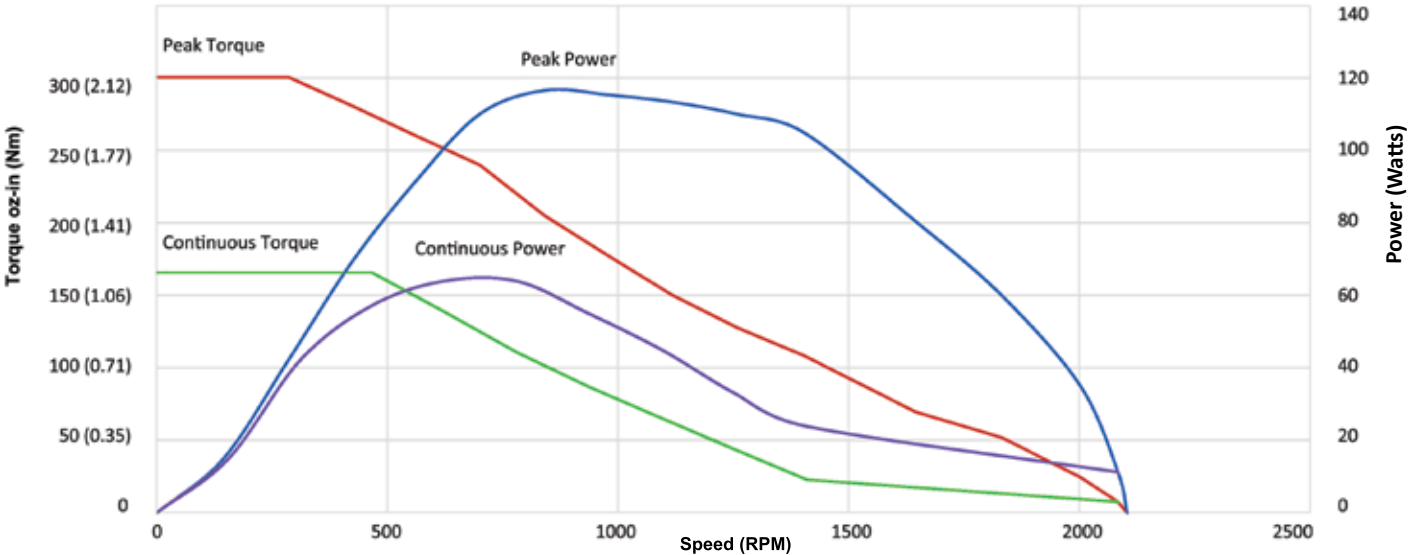

Continuous rating based on 25°C ambient temperature, motor mounted to a 6x6x¼ inch aluminum heat sink, and electronics/windings below maximum temperature. Peak torque is available for 3 seconds at a 10% duty cycle.

Overview

Software

C5 D-Style

C5 M-Style

C6 M-Style

C6 Low-Cost

Cables, Etc.

Actuators

Gearheads

Power Supplies

SM23166MT-EXX

NOTES:

1. INTERPRET DRAWING PER ASME Y14.100 AND ASME Y14.5.
2. KESEAT SHOWN IS ANSI 303 PER ANSI B17.2-1967, R1978

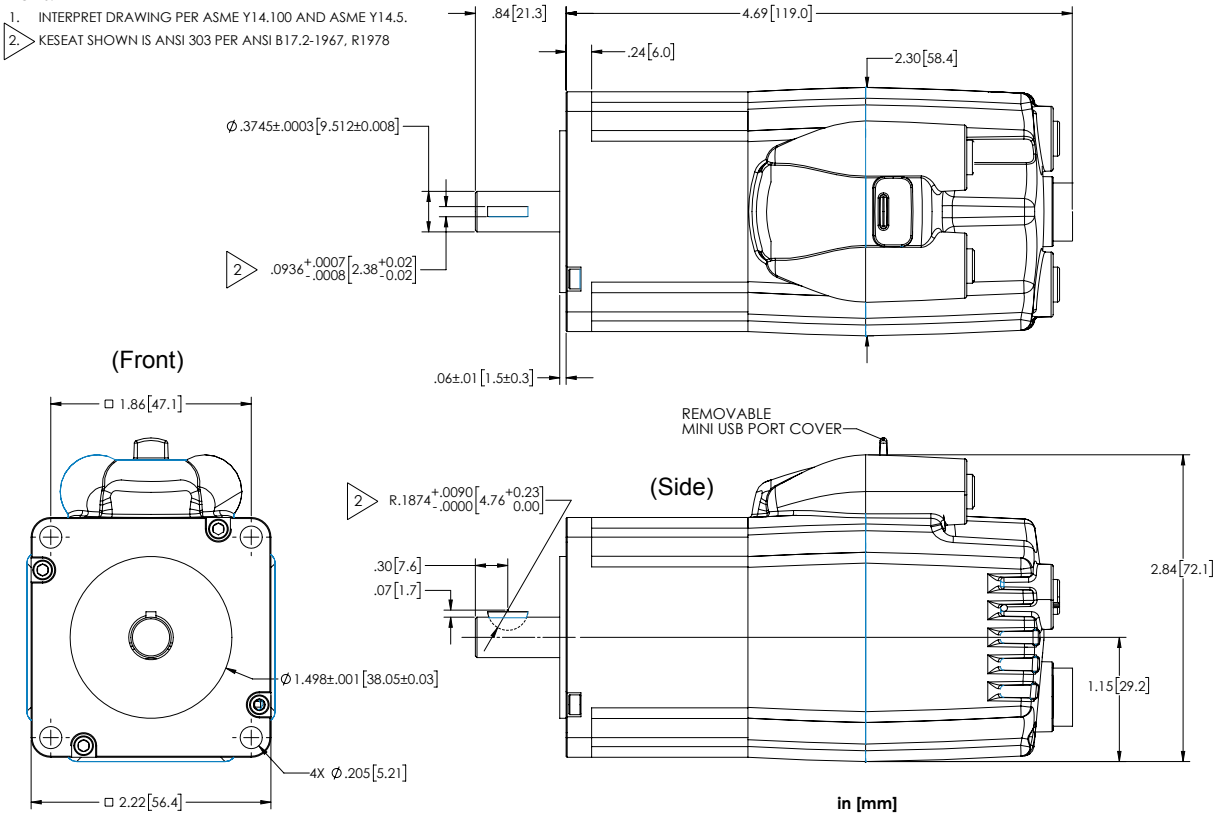

SM23216MH-EXX

NOTES:

1. INTERPRET DRAWING PER ASME Y14.100 AND ASME Y14.5.

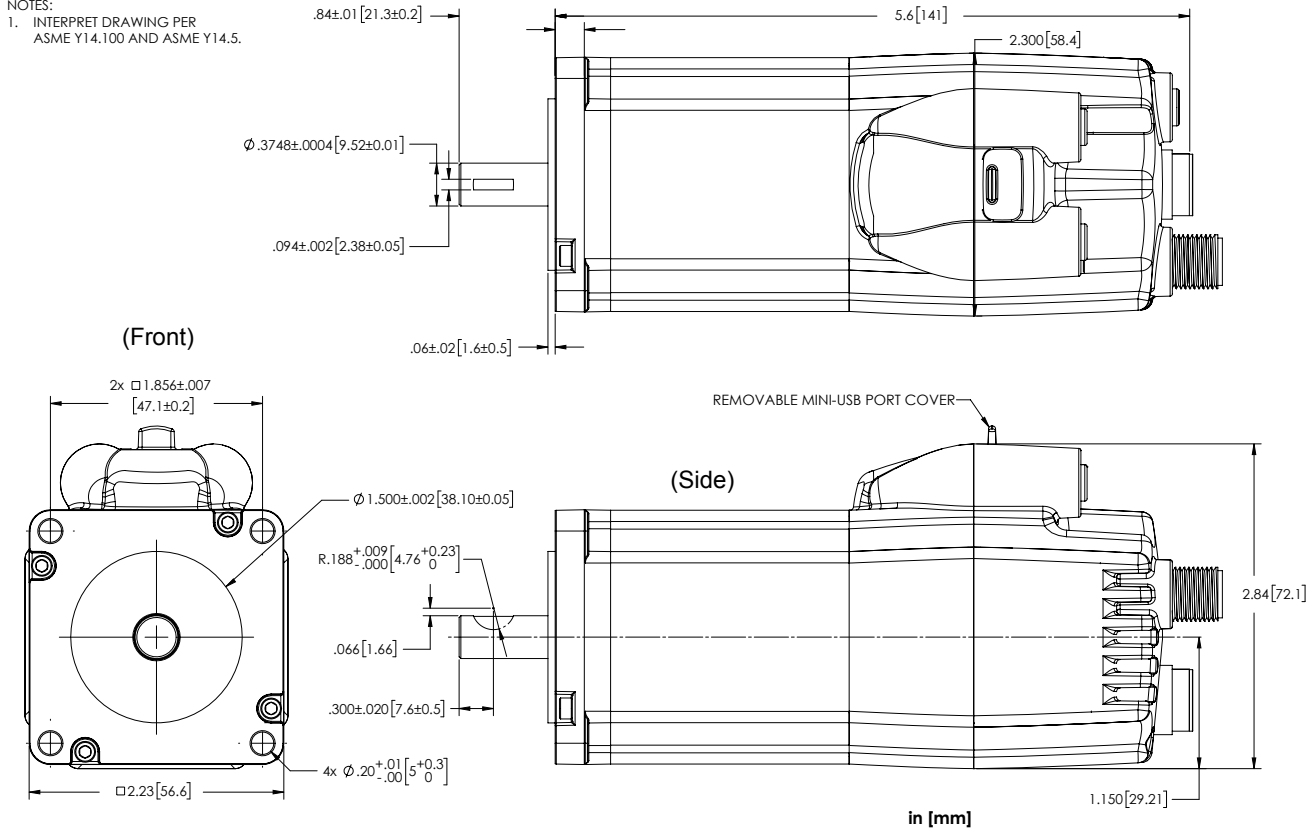

Overview

Software

C5 D-Style

C5 M-Style

C6 M-Style

C6 Low-Cost

Cables, Etc.

Actuators

Gearheads

Power Supplies

Class 6 M-Style Connector Pinouts

The following table shows the pinouts for the connectors on the Class 6 M-style SmartMotors.

| PIN | Main Power | Specifications | Notes | P1 | |
|-----|-----------------------------------------|------------------------------------------|---------------------------------------------------------------------------------------------------------------------------------------------------------------|------------------------------|---------------------------------------------------------|
| 1 | Control Power In | +24V ($\pm 20\%$), 32V Max. | Also Supplies I/O | | |
| 2 | Chassis Ground | Chassis Ground Only | Not Connected to Common | | |
| 3 | Control, Com, I/O and Amplifier Ground | Common Ground (Req'd. Ground) | Nonisolated | | |
| 4 | Amplifier Power In | +24V Min., 48V Max. | Powers Amplifier Only | | |
| PIN | Communications Connector | Specifications | Notes | P2 | |
| 1 | Control, Com, I/O and Amp Ground | Common Ground | Nonisolated | | |
| 2 | RS-485 B, Com ch. 0 | 115.2 KBAud Max. | | | |
| 3 | RS-485 A, Com ch. 0 | 115.2 KBAud Max. | | | |
| 4 | Encoder A+ Input/Output | 125 KHz Individual Line Frequency | Configurable as Encoder Output | | |
| 5 | Encoder B- Input/Output | 125 KHz Individual Line Frequency | Configurable as Encoder Output | | |
| 6 | Encoder A- Input/Output | 125 KHz Individual Line Frequency | Configurable as Encoder Output | | |
| 7 | +5V Out | 50 mA Max. | | | |
| 8 | Encoder B+ Input/Output | 125 KHz Individual Line Frequency | Configurable as Encoder Output | | |
| PIN | 24V I/O Connector | Specifications | Notes | P3 | |
| 1 | IN0 GP, Discrete or Analog Input | Inp Impedance > 10 kohm | For Inputs: 7 Configurable Inputs Low Lvl Thld: 3.6V Max. High Lvl Thld: 5.0V Min. Inp Hysteresis: 1.0V Min. Analog Input Scale: 10V FS | | |
| 2 | IN1 GP, Discrete or Analog Input | Inp Impedance > 10 kohm | | | |
| 3 | IN2 Pos Limit or GP | Inp Impedance > 10 kohm | | | |
| 4 | IN3 Neg Limit or GP | Inp Impedance > 10 kohm | | | |
| 5 | IN4 GP or Ext. Enc. Index Capture | Inp Impedance > 10 kohm | | | |
| 6 | IN5 GP or Int. Enc. Index Capture | Inp Impedance > 10 kohm | | | |
| 7 | IN6 GP, G Cmd, or Homing Inp (EtherCAT) | Inp Impedance > 10 kohm | | | |
| 8 | IN7 Drive Enable | Inp Impedance > 10 kohm | | | |
| 9 | OUT8 Brake or GP | 250 mAmps Max. | | | For Outputs: Do Not Exceed 500 mAmps Combined |
| 10 | OUT9 NOT FAULT | 250 mAmps Max. | | | |
| 11 | +24 VDC Out (Supplied from P1, Pin 1) | 12.5V Min., 23V Max. Load 2 Amps Max. | | | |
| 12 | Ground Common | Common Ground | Nonisolated | | |
| PIN | Industrial Ethernet Connectors | | Specifications | Notes | P4 |
| | EtherNet/IP, EtherCAT | PROFINET | 10/100BASE-T | Shield tied to motor housing | |
| 1 | +TX | +TD | EtherCAT=100BASE-TX | EtherCAT=Input(L), Output(R) | |
| 2 | +RX | +RD | | | |
| 3 | -TX | -TD | | | |
| 4 | -RX | -RD | | | |

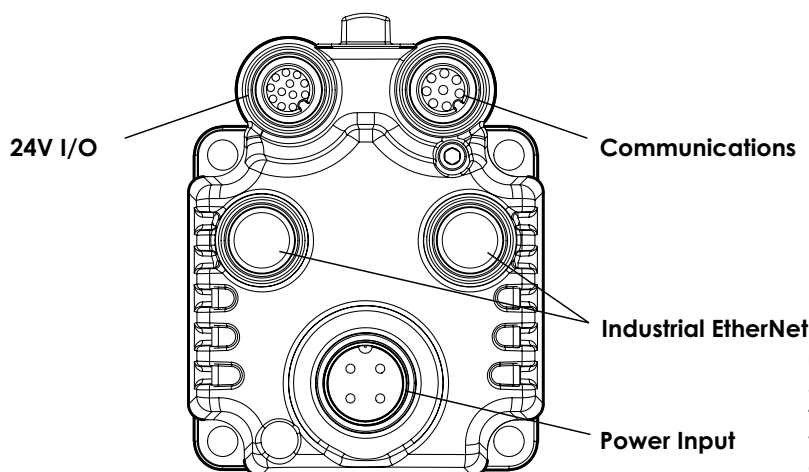

CAUTION: Exceeding 32 VDC into control power on any of the +24V pins may cause immediate damage to the internal electronics. Exceeding a sustained voltage of 48V to pin 4 of the P1 Power Input may cause immediate damage to the internal electronics. Exceeding these voltage limits will void the warranty.