

## CBLI052-5M Cable for the D-Style SmartMotor™



### Application Note

Revised: 09/28/2022

# Copyright Notice

Copyright © 2022, Moog Inc.

Application Note: CBLI052-5M Cable for the D-Style SmartMotor™, Revised: 09/28/2022.

This document, as well as the software described in it, is furnished under license and may be used or copied only in accordance with the terms of such license. The content of this manual is furnished for informational use only, is subject to change without notice and should not be construed as a commitment by Moog Inc., Animatics. Moog Inc., Animatics assumes no responsibility or liability for any errors or inaccuracies that may appear herein.

Except as permitted by such license, no part of this publication may be reproduced, stored in a retrieval system or transmitted, in any form or by any means, electronic, mechanical, recording, or otherwise, without the prior written permission of Moog Inc., Animatics.

The programs and code samples in this manual are provided for example purposes only. It is the user's responsibility to decide if a particular code sample or program applies to the application being developed and to adjust the values to fit that application.

Moog Animatics and the Moog Animatics logo, SmartMotor and the SmartMotor logo, Combitronic and the Combitronic logo are all trademarks of Moog Inc., Animatics. Other trademarks are the property of their respective owners.

Please let us know if you find any errors or omissions in this manual so that we can improve it for future readers. Such notifications should contain the words "Application Note: CBLI052-5M Cable for the D-Style SmartMotor™" in the subject line and be sent by e-mail to: [animatics\\_marcom@moog.com](mailto:animatics_marcom@moog.com). Thank you in advance for your contribution.

Contact Us:

**Americas - West**

Moog Animatics  
2581 Leghorn Street  
Mountain View, CA 94043  
USA

**Americas - East**

Moog Animatics  
1995 NC Hwy 141  
Murphy, NC 28906  
USA

Tel: 1 650-960-4215

Support: 1 (888) 356-0357

Website: [www.animatics.com](http://www.animatics.com)

Email: [animatics\\_sales@moog.com](mailto:animatics_sales@moog.com)

---

# Table Of Contents

<b>Introduction</b> .....	<b>4</b>
Purpose .....	5
Overview .....	5
Equipment Required .....	5
Hardware .....	5
Software .....	5
Safety Symbols .....	5
Additional Documents .....	6
Related Guides .....	6
Other Documents .....	6
Additional Resources .....	7
<b>Technical Information</b> .....	<b>8</b>
Dimension Drawing and Pinouts .....	9
SmartMotor Interface .....	10
DE Control Power Input Rating .....	11
Internal Connector Head Schematic .....	11
<b>Application Information</b> .....	<b>12</b>
Application Wiring .....	13
Application Program .....	14
I/O Commands .....	16
<b>Revision History</b> .....	<b>17</b>

# Introduction

This chapter provides information on the purpose of this document. It also provides information on safety, and where to find related documents and additional resources.

<b>Purpose</b> .....	<b>5</b>
<b>Overview</b> .....	<b>5</b>
<b>Equipment Required</b> .....	<b>5</b>
Hardware .....	5
Software .....	5
<b>Safety Symbols</b> .....	<b>5</b>
<b>Additional Documents</b> .....	<b>6</b>
Related Guides .....	6
Other Documents .....	6
<b>Additional Resources</b> .....	<b>7</b>

## Purpose

This document provides mechanical drawings, internal schematics and application information for the CBLI052-5M cable.

**NOTE:** The CBLI052-5M cable supports all legacy I/O cable part numbers.

## Overview

The CBLI052-5M cable connects directly into the SmartMotor's DB 15 I/O connector on 17-, 23- and 34-frame D-style motors. The cable has the ability to support up to five inputs and two outputs OR four inputs and three outputs. That feature is enabled through pin 7, I/O 6, which can be either an input OR output but not both simultaneously. Additionally, if the connecting SmartMotor has the DE option, then leads 14 and 15 of the cable should be connected, which brings 24 VDC or 48 VDC to the motor's controller on pins 14 and 15. Refer to the next figure for details.

**NOTE:** The DE option allows the user to turn off power to the motor while keeping the controller power on.

## Equipment Required

The CBLI052-5M cable requires this equipment:

### Hardware

- Class 5 D-style SmartMotor with appropriate power supply
- A personal computer running the Windows operating system

### Software

- Moog Animatics SMI software

## Safety Symbols

The document uses the following safety symbols:



**CAUTION:** This symbol indicates a potentially minor hazard, where failure to comply with the instructions could result in slight injury to the operator or minor damage to the equipment.

---

**NOTE:** Notes are used to emphasize non-safety concepts or related information.

For additional safety information and resources, refer to the Installation and Startup Guide for your SmartMotor.

## Additional Documents

The Moog Animatics website contains additional documents that are related to the information in this manual. Please refer to these lists.

### Related Guides

- Moog Animatics SmartMotor™ Installation & Startup Guides  
<http://www.animatics.com/install-guides>
- *SmartMotor™ Developer's Guide*  
<http://www.animatics.com/smartmotor-developers-guide>
- *SmartMotor™ System Best Practices Application Note*  
<http://www.animatics.com/system-best-practices-application-note>

In addition to the documents listed above, guides for fieldbus protocols and more can be found on the website: <https://www.animatics.com/support/downloads.manuals.html>

### Other Documents

- SmartMotor™ Certifications  
<https://www.animatics.com/certifications.html>
- *SmartMotor Developer's Worksheet*  
(interactive tools to assist developer: Scale Factor Calculator, Status Words, CAN Port Status, Serial Port Status, RMODE Decoder and Syntax Error Codes)  
<https://www.animatics.com/support/downloads.knowledgebase.html>
- *Moog Animatics Product Catalog*  
<http://www.animatics.com/support/moog-animatics-catalog.html>

## **Additional Resources**

The Moog Animatics website contains useful resources such as product information, documentation, product support and more. Please refer to these addresses:

- General company information:  
<http://www.animatics.com>
- Product information:  
<http://www.animatics.com/products.html>
- Product support (Downloads, How-to Videos, Forums and more):  
<http://www.animatics.com/support.html>
- Contact information, distributor locator tool, inquiries:  
<https://www.animatics.com/contact-us.html>
- Applications (Application Notes and Case Studies):  
<http://www.animatics.com/applications.html>

## Technical Information

This chapter provides technical information about the CBLI052-5M cable (e.g., connector pinouts, wire colors, specifications and ratings, etc.).

Dimension Drawing and Pinouts .....	9
SmartMotor Interface .....	10
DE Control Power Input Rating .....	11
Internal Connector Head Schematic .....	11



## Dimension Drawing and Pinouts

The next figure shows a dimension drawing and pin assignments for the CBLIO52-5M cable. It is up to the user to determine how many inputs and outputs are needed for their application.

**NOTE:** Any unneeded wires can be trimmed by the user.

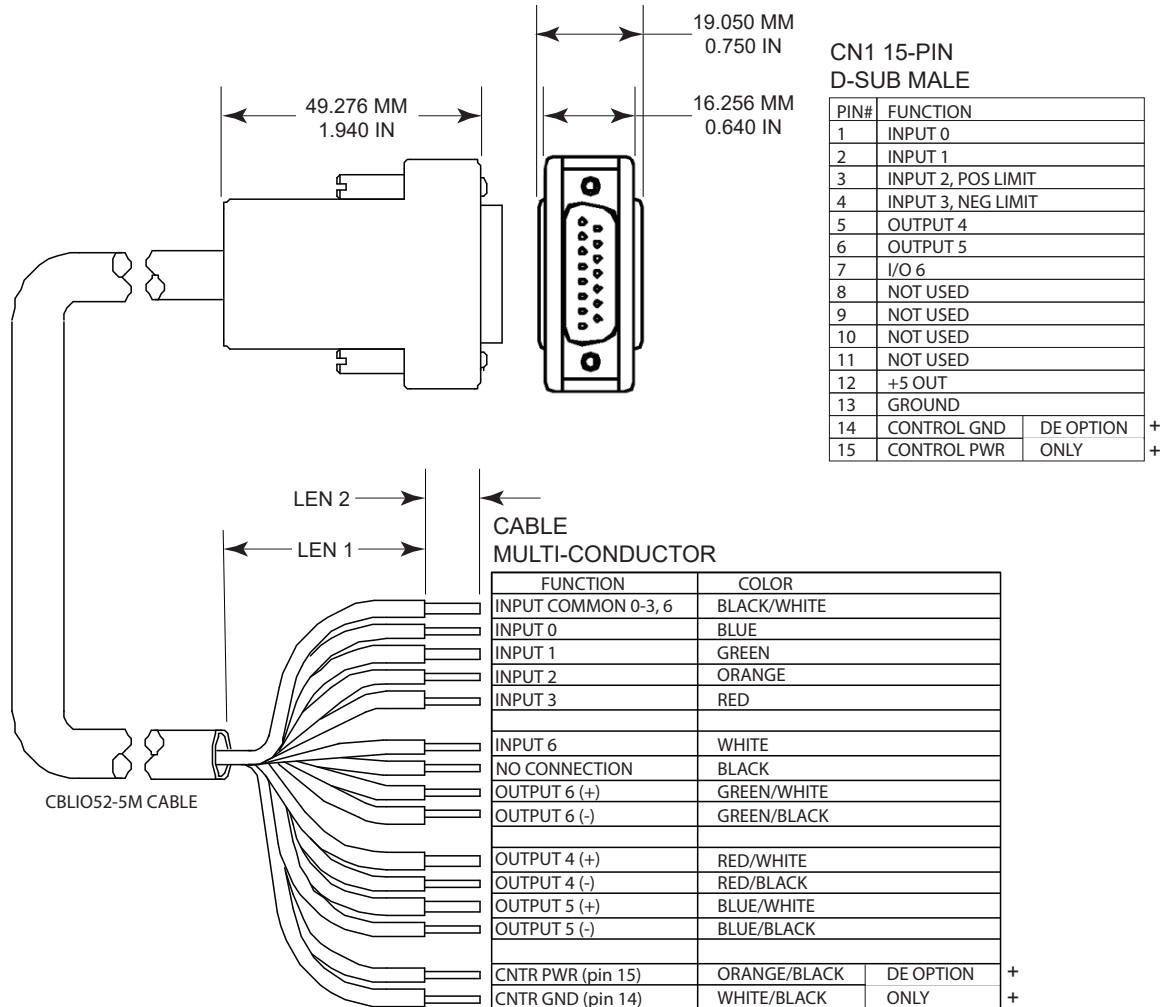

OUTPUT CONNECTIONS CAN BE WIRED IN A SINKING OR SOURCING CONFIGURATION:  
 FOR SOURCING THE (+) IS TIED TO 24V, AND THE SIGNAL IS THE (-).  
 FOR SINKING THE (-) IS TIED TO GROUND, AND THE SIGNAL IS THE (+).

INPUT COMMON CAN BE CONNECTED TO +24V OR GND. INPUTS ARE TRIGGERED WITH PLUS OR MINUS 24V BETWEEN THEM AND THE INPUT COMMON.

+TO BE USED WITH DE OPTION SMARTMOTORS FOR KEEPING CONTROLLER ALIVE DURING E-STOP. INPUT VOLTAGE RANGES FROM 24 VDC TO 48 VDC, DO NOT EXCEED 48 VDC.

PART NUMBER	CABLE LEN	LEN 1	LEN 2
CBLIO52-5M	5 M 16.4 FT	76.2 MM 3.0 IN	12.7 MM 0.5 IN

**MULTICONDUCTOR CABLE**

HOOD COLOR: BLACK  
 JACKET COLOR: GRAY  
 CONDUCTORS: 20-26 AWG  
 OUTSIDE DIAMETER: 0.276 IN, 7.010 MM  
 MIN. BEND RADIUS: 3.312 IN, 84.125 MM

Inputs 0 - 3 and 6 can be set to either all sourcing inputs or all sinking inputs. Outputs 4, 5, and 6 are wired independently, so they can either be sourcing or sinking.



**CAUTION:** Damage may occur if the maximum ratings are exceeded.

INPUT	Min voltage	19 VDC
	Max voltage	30 VDC
	Min current	5 mA
	Max current	8 mA
OUTPUT	Max voltage	30 VDC
	Max current	100 mA at 50° C ambient

## SmartMotor Interface

The CBLI052-5M cable uses I/O pins on the SmartMotor's P2 DB-15 D-sub connector. The next table provides a brief description of the corresponding pins.



**CAUTION:** Pins 14 and 15 are intended for use with a DE option SmartMotor for control power only.

PIN	SIGNAL	DESCRIPTION
1	Input 0	Digital input 0 / Encoder input A / Step input (input frequency 50 kHz)
2	Input 1	Digital input 1 / Encoder input B / Direction input (input frequency 50 kHz)
3	Input 2	Digital input 2 / Positive Limit
4	Input 3	Digital input 3 / Negative Limit
5	Output 4	Digital output 4
6	Output 5	Digital output 5
7	Input/Output 6	Digital input/output 6
12	+5 VDC	+5 VDC output
13	GND	Signal Ground
14	CNTR GND	For SmartMotor with DE option, Control GND
15	CNTR PWR	For SmartMotor with DE option, Control POWER

For a detailed description of the P2 connector pins and the other D-style SmartMotor connectors, see the Installation and Startup Guide for your SmartMotor.

## DE Control Power Input Rating

The next table contains information on the minimum and maximum DE Control Power input.



**CAUTION:** Damage may occur if the maximum ratings are exceeded.

INPUT	Min voltage	20 VDC	Min current	60 mA
	Max voltage	48 VDC	Max current	100 mA

## Internal Connector Head Schematic

The next figure shows a schematic diagram of the circuitry within the CBLI052-5M cable connector head.

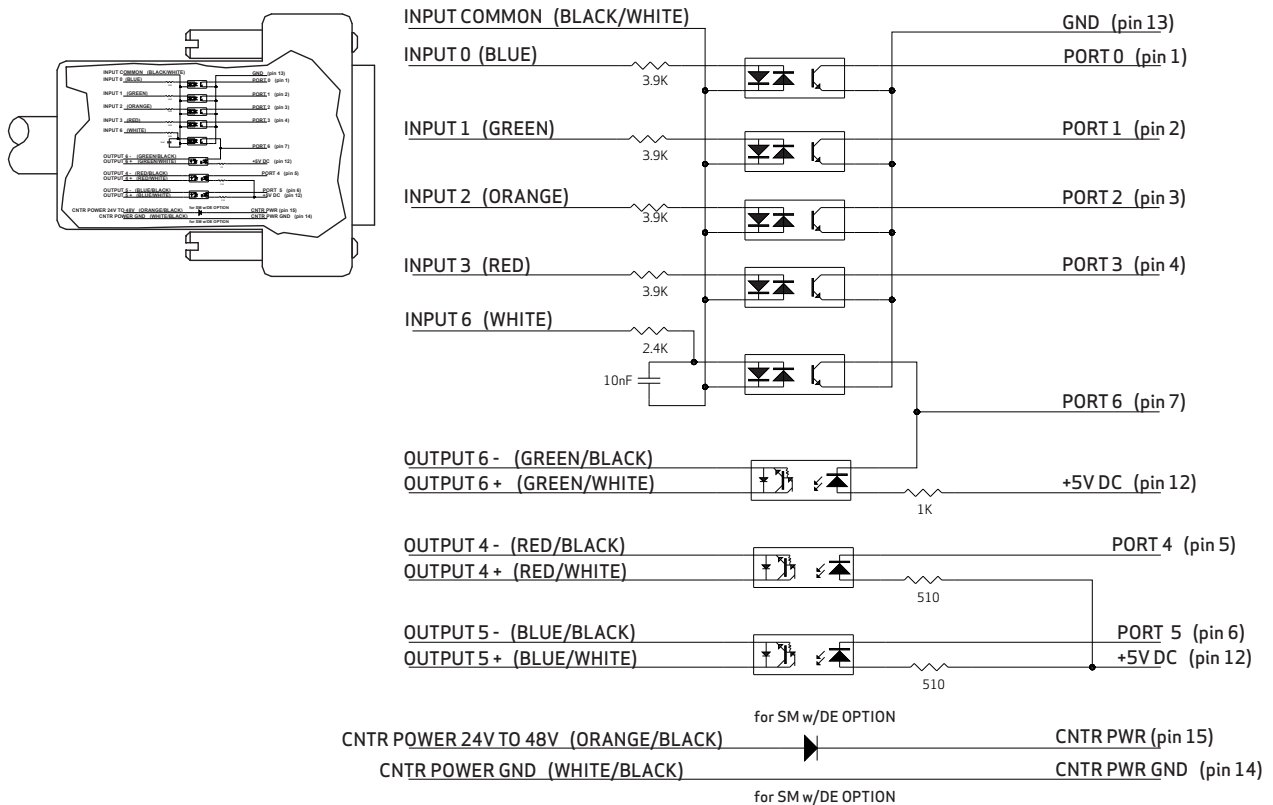

## Application Information

This chapter provides a wiring diagram, example code and other details for using the CBLI052-5M cable in an application.

Application Wiring .....	13
Application Program .....	14
I/O Commands .....	16

## Application Wiring

The CBLI052-5M cable is used to interface the SmartMotor with a PLC and some coil relays. A sample application wiring is shown in the next figure.

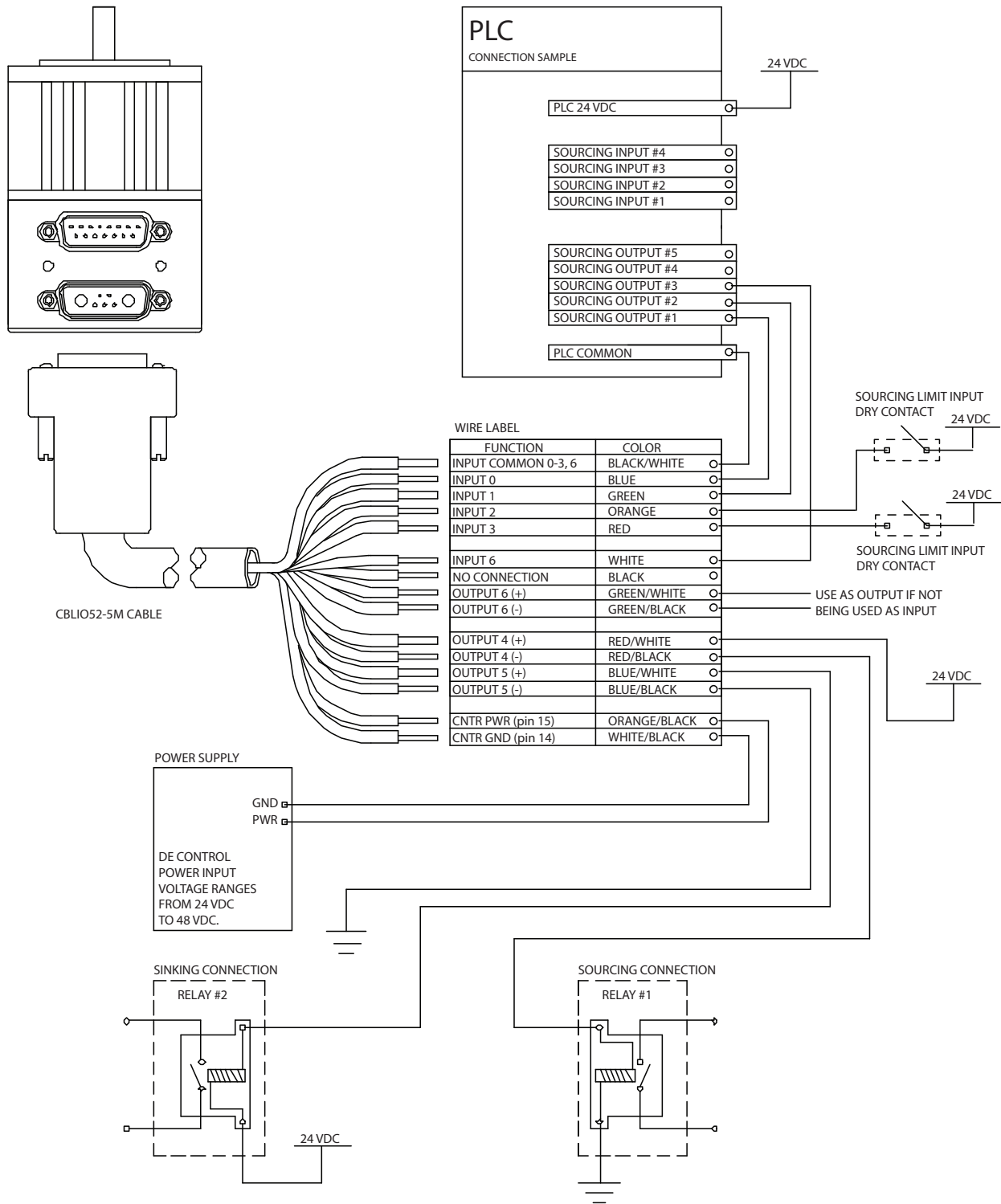

## Application Program

The previous figure is an example of using the CBLI052-5M cable to interface the SmartMotor with a PLC. The sample program below reads output signal from the PLC to determine which predefined profile to run. After a move completed, the SmartMotor will signal back to the PLC. Also, the SmartMotor will set the fault signal high and send a message to the terminal if an error occurs.

**NOTE:** The outputs and inputs shown in the next code example are correct. The logic is reversed by the CBLI052-5M cable.

```

1. 'SAMPLE PROGRAM USING I/O
2. 'INPUT 0 to 2 for PLC profile selection
3. 'INPUT 3 for read ready
4. 'OUTPUT 6 motor signal PLC after motion completed
5. 'OUTPUT 4 and 5 to turn on/off pump and valve
6. '
7. 'initialize I/O ports
8. EIGN(0)      'initialize port 0 as input, signal input bit 0
9. EIGN(1)      'initialize port 1 as input, signal input bit 1
10. EILP        'initialize port 3 as RT Limit input
11. EILN        'initialize port 4 as LT Limit input
12. OUT(4)=1    'set output 4 off
13.             'initialize port 4 as output, trajectory
14.             'start(high)/ended(low)
15. OUT(5)=1    'set output 5 off
16.             'initialize port 5 as output, fault(high)
17. EIGN(6)     'initialize port 6 as input, read ready trigger
18. 'set acceleration/velocity
19. MP          'set motor to Mode Position
20. ADT=8*100   'set acceleration
21. VT=32212*30 'set velocity
22. WHILE 1    'infinite WHILE LOOP
23.   WHILE IN(6)==1 LOOP 'gate, waiting for PLC read ready signal
24.   OUT(5)=1   'reset the fault output if any
25.   ab[0]=IN(0) 'if input 0 triggered, IN(0) will read 0,
26.               ' otherwise ab[0] is 1
27.   ab[1]=IN(1)*2 'if input 1 triggered, IN(1) will read 0,
28.               ' otherwise ab[1] is 2
29.   a=ab[0]+ab[1] 'summing up the binary values
30.   SWITCH a      'comparing each binary value with the
31.               ' SWITCH/CASE
32.               ' statement
33.   CASE 0        'CASE 0 when 1 0 triggered ( 0 0)
34.     PRINT("CASE 0 move to PT=8000",#13)
35.     PT=8000    'set position value
36.     GOSUBO     'GO to SUBroutine C0 to start motion and
37.               ' error handling
38.   BREAK        'BREAK out of SWITCH statement
39.   CASE 1        'CASE 1 when 1 _ triggered ( 0 1)
40.     PRINT("CASE 1 move to PT=10000",#13)
41.     PT=10000   'set position value
42.     GOSUBO     'GO to SUBroutine C0 to start motion and
43.               ' error handling
44.   BREAK

```

```

45.     CASE 2           'CASE 2 when _ 0 triggered ( 1 0 )
46.     PRINT("CASE 2 move to PT=-8000",#13)
47.     PT=-8000       'set position value
48.     GOSUBO         'GO to SUBroutine C0 to start motion and
49.                     ' error handling
50.     BREAK
51.     CASE 3           'CASE 3 when __ triggered ( 0 0 )
52.     PRINT("CASE 3 move to PT=-10000",#13)
53.     PT=-10000      'set position value
54.     GOSUBO         'GO to SUBroutine C0 to start motion and
55.                     ' error handling
56.     BREAK
57.     ENDS           'ENDS for closing SWITCH statement
58. LOOP              'LOOP for closing WHILE statement
59. END               'END marks end of program
60.
61. C0                'Label for subroutine C0
62. OUT(4)=0          'output high, trajectory started
63. G                 'start trajectory (motion)
64. TWAIT            'wait until trajectory ends (motion stopped)
65. OUT(4)=1          'reset signal to RESET MOTION (low) signal to PLC
66. IF Be            'checking excessive position error bit
67.     PRINT("Excessive position error occurred",#13) 'print
68.                 ' to terminal window
69.     OUT(5)=0      'set fault signal (high)
70. ENDIF
71. IF Bp            'checking RT limit bit
72.     PRINT("RT limit reached",#13) 'print to terminal window
73.     OUT(5)=0      'set fault signal (high)
74. ENDIF
75. IF Bm            'checking LT limit bit
76.     PRINT("LT limit reached",#13) 'print to terminal window
77.     OUT(5)=0      'set fault signal (high)
78. ENDIF
79. IF Bh            'checking over temperature bit
80.     PRINT("Overtemperature occurred",#13) 'print to terminal window
81.     OUT(5)=0      'set fault signal (high)
82. ENDIF
83. RETURN           'RETURN to main program

```

As noted, the motor is reading the signal as low when a high signal is being sent to the CBLI052-5M cable. If you prefer the motor to read the signal as high when a high signal is being sent to the cable, you can mask the input value by using this command:

```

a=EIGN(0)==0      'this sets a to 1 if EIGN(0) is true, which in this case
                  ' if EIGN(0) is 0 (low)

```

## I/O Commands

This section shows examples of some I/O commands. For more details on I/O commands, see the *SmartMotor Developer's Guide*, available at: <http://www.animatics.com/smartmotor-developers-guide>.

**NOTE:** The outputs and inputs shown in the code example are correct. The logic is reversed by the CBLI052-5M cable.

```
EIGN(0)    'initialize port 0 as input
EIGN(1)    'initialize port 1 as input
EIGN(2)    'initialize port 2 as input
EIGN(3)    'initialize port 3 as input
EILP      'initialize port 2 as Right Limit (Port 2 is right/pos limit by default)
EILN      'initialize port 3 as Left Limit (Port 3 is left/neg limit by default)
EIGN(6)    'initialize port 5 as input (port 6 can only be used as either
           'an input OR output, but not both simultaneously)
'initialize port 6 as output or input
OUT(6)=1   'set output 6 off (output line open)
OUT(6)=0   'set output 6 on (output line close)
'initialize port 4 as output or input
OUT(4)=1   'set output 4 off (output line open)
OUT(4)=0   'set output 4 on (output line close)
'initialize port 5 as output or input
OUT(5)=1   'set output 5 off (output line open)
OUT(5)=0   'set output 5 on (output line close)

d=IN(2)    'store the input state value of port 2 into variable d

IF IN(0)==1 'using with IF statement, true => IN(0) is 1
ENDIF

IF IN(0)==0 'using with IF statement, true => IN(0) is 0
ENDIF
```



## Revision History

2022-09-28

- Initial release

# TAKE A CLOSER LOOK

Moog Animatics, a sub-brand of Moog Inc. since 2011, is a global leader in integrated automation solutions. With over 30 years of experience in the motion control industry, the company has U.S. operations and international offices in Germany and Japan as well as a network of Automation Solution Providers worldwide.

Americas - West  
Moog Animatics  
2581 Leghorn Street  
Mountain View, CA 94043  
United States

Americas - East  
Moog Animatics  
1995 NC Hwy 141  
Murphy, NC 28906  
United States

Europe  
Moog GmbH  
Memmingen Branch  
Allgaeustr. 8a  
87766 Memmingerberg  
Germany

Asia  
Moog Animatics  
Kichijoji Nagatani City Plaza 405  
1-20-1, Kichijojihoncho  
Musashino-city, Tokyo 180-0004  
Japan

Tel: +1 650-960-4215  
Email: [animatics\\_sales@moog.com](mailto:animatics_sales@moog.com)

Tel: +49 8331 98 480-0  
Email: [info.mm@moog.com](mailto:info.mm@moog.com)

Tel: +81 (0)422 201251  
Email: [mcg.japan@moog.com](mailto:mcg.japan@moog.com)

For Animatics product information, visit [www.animatics.com](http://www.animatics.com)

For more information or to find the office nearest you, email [animatics\\_sales@moog.com](mailto:animatics_sales@moog.com)

Moog is a registered trademark of Moog Inc. and its subsidiaries.  
All trademarks as indicated herein are the property of Moog Inc. and its subsidiaries.  
©2022 Moog Inc. All rights reserved. All changes are reserved.

Moog AnimaticsCBLI052-5M Cable for the D-Style SmartMotor™, Revised: 09/28/2022