

APPLICATION NOTE FOR

FULLY INTEGRATED SERVO MOTORS

SYSTEM BEST PRACTICES FOR
CLASS 5 AND 6 SMARTMOTOR™ WITH
COMBITRONIC™ TECHNOLOGY



Revised: 06/23/2022

DESCRIBES THE BEST PRACTICES FOR
OPTIMUM PERFORMANCE WHEN BUILDING
SMARTMOTOR™ SYSTEMS

Copyright Notice

Copyright © 2016-2022, Moog Inc.

Moog Animatics System Best Practices Application Note, Revised: 06/23/2022.

This document, as well as the software described in it, is furnished under license and may be used or copied only in accordance with the terms of such license. The content of this manual is furnished for informational use only, is subject to change without notice and should not be construed as a commitment by Moog Inc., Animatics. Moog Inc., Animatics assumes no responsibility or liability for any errors or inaccuracies that may appear herein.

Except as permitted by such license, no part of this publication may be reproduced, stored in a retrieval system or transmitted, in any form or by any means, electronic, mechanical, recording, or otherwise, without the prior written permission of Moog Inc., Animatics.

The programs and code samples in this manual are provided for example purposes only. It is the user's responsibility to decide if a particular code sample or program applies to the application being developed and to adjust the values to fit that application.

Moog Animatics and the Moog Animatics logo, SmartMotor and the SmartMotor logo, Combitronic and the Combitronic logo are all trademarks of Moog Inc., Animatics. Other trademarks are the property of their respective owners.

Please let us know if you find any errors or omissions in this manual so that we can improve it for future readers. Such notifications should contain the words "System Best Practices Application Note" in the subject line and be sent by e-mail to: animatics_marcom@moog.com. Thank you in advance for your contribution.

Contact Us:

Americas - West

Moog Animatics
2581 Leghorn Street
Mountain View, CA 94043
USA

Tel: 1 650-960-4215

Americas - East

Moog Animatics
1995 NC Hwy 141
Murphy, NC 28906
USA

Tel: 1 610-328-4000 x3842

Fax: 1 540-557-6509

Support: 1 (888) 356-0357

Website: www.animatics.com

Email: animatics_sales@moog.com

Table Of Contents

Introduction	7
Purpose	8
Safety Information	9
Safety Symbols	9
Other Safety Considerations	9
Motor Sizing	9
Environmental Considerations	10
Machine Safety	10
Documentation and Training	11
Additional Equipment and Considerations	11
Safety Information Resources	11
Additional Documents	13
Related Guides	13
Other Documents	13
Additional Resources	14
Grounding, Shielding and Noise Reduction	15
Causes of Noise	16
Ground Loops	16
Avoid Communications Ground Loops	16
Avoid I/O Ground Loops	17
Star Grounding	18
Shielded Cables	19
Drain Wire	20
Ferrite Beads (Chokes)	20
Noise Filtering	21
Communications	22
RS-232 Communications	23
RS-485 Communications	23
RS-422 Communications	23
CAN Bus Communications	23
PROFIBUS Communications	25
Ethernet Communications	25
USB Communications	25

I/O	26
Logic Level (5V TTL)	27
24V and Variations	27
AD1 Option	27
Higher Current Capacity I/O	28
Protections for I/O	28
External	28
Process, Power-Up Timing Methods	28
Analog Considerations	29
Encoder I/O, Single-Ended, Differential	29
Power-Up Management and E-Stop	30
Power Supply	31
Compute the Required Current	31
Fuse the Connection	31
Select the Proper Supply Type	31
Operate at or below 48 VDC	32
Other Considerations	32
Comparison between Linear and Switching supplies	32
What concerns are there with maximizing voltage on the supply?	34
How do I size power supplies?	34
Changing Input Voltage on Open Frame Power Supplies	35
Bus Voltage Fluctuations	36
Causes	36
Protections	36
External Devices	36
Process, Power-Up Timing Methods	36
Disconnecting Power	37
Control Power Switch	37
E-Stop Switches	37
Using Separate Drive and Control Power	37
DE Power Option	38
Shunts	40
Why Are Shunts Needed?	40
Back EMF and Regenerative Energy	40
Selecting the Correct Size Shunt	41

Gearheads	43
Non-Captive Gearheads	44
Gearhead Torque Notes	44
Mounting Procedure for Non-Captive Gearhead	44
Gearhead Sizing Example	46
Mechanical Considerations	47
Torque Curves	48
Understanding Torque Curves	48
Peak Torque	48
Continuous Torque	48
Ambient Temperature Effects on Torque Curves and Motor Response	49
Supply Voltage Effects on Torque Curves and Motor Response	49
Example 1: Rotary Application	50
Example 2: Linear Application	50
Dyno Test Data vs. the Derated Torque Curve	50
Proper Sizing and Loading of the SmartMotor	51
Motor Sizing	53
Friction	53
Vertical Load	53
Acceleration	53
Inertia	53
Motor Shaft Loading	54
Axial Force	54
Radial Force	54
Moment of Inertia	54
Matching Motor to Load	54
Improving the Moment of Inertia Ratio	55
Gear Reduction Example	55
Application Sizing Equations	55
Calculating Power—The Real Story	55
Formula for Power to Torque:	56
Typical Friction Coefficients	56
Equation Symbol Definitions	57
Sizing Equations	58
Motor Mounting	59
Procedure	59
Cable Flex	62

Environmental Considerations	63
Thermal	64
Temperature Considerations	64
Heat Sinking	64
Humidity	65
IP Sealing	65
Clean Room	67
Clean Air Purge and Vacuum	67
Clean Room Classifications	67
High Altitude	67
Vacuum	68
FAQs	69
Downloading and Uploading Programs	69
I/O Handling	69
Power Supplies	70
Back EMF	70
Communications	71
Success Checklist	73
Glossary	75
Revision History	82

Introduction

This chapter provides an overview of the purpose of this document. It also provides information on safety, and where to find related documents and additional resources.

Purpose	8
Safety Information	9
Safety Symbols	9
Other Safety Considerations	9
Motor Sizing	9
Environmental Considerations	10
Machine Safety	10
Documentation and Training	11
Additional Equipment and Considerations	11
Safety Information Resources	11
Additional Documents	13
Related Guides	13
Other Documents	13
Additional Resources	14

Purpose

This document describes system installation best practices for the Moog Animatics SmartMotor™. The purpose is to highlight the basic points that system builders should keep in mind when integrating a SmartMotor into the design. Because system design is quite complex, this document focuses on only those items that directly affect the integration and performance of the SmartMotor.

NOTE: This document is not intended to be a tutorial on system design. It is provided as a supplement to the installation and programming information described in the SmartMotor installation, developer and fieldbus guides. It is the responsibility of the system designer to read and follow the documentation for the selected SmartMotors.

Safety Information

This section describes the safety symbols and other safety information.

Safety Symbols

The manual may use one or more of these safety symbols:



DANGER: This symbol indicates a potentially lethal electrical hazard for the operator, where failure to comply with the instructions could result in operator death.



DANGER: This symbol indicates a potentially lethal mechanical hazard for the operator, where failure to comply with the instructions could result in operator death.



WARNING: This symbol indicates a potentially nonlethal electrical hazard, where failure to comply with the instructions could result in serious injury to the operator or major damage to the equipment.



WARNING: This symbol indicates a potentially nonlethal mechanical hazard, where failure to comply with the instructions could result in serious injury to the operator or major damage to the equipment.



CAUTION: This symbol indicates a potentially minor hazard, where failure to comply with the instructions could result in slight injury to the operator or minor damage to the equipment.

NOTE: Notes are used to emphasize non-safety concepts or related information.

Other Safety Considerations

The Moog Animatics SmartMotors are supplied as components that are intended for use in an automated machine or system. As such, it is beyond the scope of this manual to attempt to cover all the safety standards and considerations that are part of the overall machine/system design and manufacturing safety. Therefore, this information is intended to be used only as a general guideline for the machine/system designer.

It is the responsibility of the machine/system designer to perform a thorough "Risk Assessment" and to ensure that the machine/system and its safeguards comply with the safety standards specified by the governing authority (for example, ISO, OSHA, UL, etc.) for the site where the machine is being installed and operated. For more details, see Machine Safety on page 10.

Motor Sizing

It is the responsibility of the machine/system designer to select SmartMotors that are properly sized for the specific application. Undersized motors may: perform poorly, cause excessive downtime or cause unsafe operating conditions by not being able to handle the loads placed on them. The *System*

Best Practices document, which is available on the Moog Animatics website, contains information and equations that can be used for selecting the appropriate motor for the application.

Replacement motors must have the same specifications and firmware version used in the approved and validated system. Specification changes or firmware upgrades require the approval of the system designer and may require another Risk Assessment.

Environmental Considerations

It is the responsibility of the machine/system designer to evaluate the intended operating environment for dust, high-humidity or presence of water (for example, a food-processing environment that requires water or steam wash down of equipment), corrosives or chemicals that may come in contact with the machine, etc. Moog Animatics manufactures specialized IP-rated motors for operating in extreme conditions. For details, see the *Moog Animatics Product Catalog*.

Machine Safety

In order to protect personnel from any safety hazards in the machine or system, the machine/system builder must perform a "Risk Assessment", which is often based on the ISO 13849 standard. The design/implementation of barriers, emergency stop (E-stop) mechanisms and other safeguards will be driven by the Risk Assessment and the safety standards specified by the governing authority (for example, ISO, OSHA, UL, etc.) for the site where the machine is being installed and operated. The methodology and details of such an assessment are beyond the scope of this manual. However, there are various sources of Risk Assessment information available in print and on the internet.

NOTE: The next list is an example of items that would be evaluated when performing the Risk Assessment. Additional items may be required. The safeguards must ensure the safety of all personnel who may come in contact with or be in the vicinity of the machine.

In general, the machine/system safeguards must:

- Provide a barrier to prevent unauthorized entry or access to the machine or system. The barrier must be designed so that personnel cannot reach into any identified danger zones.
- Position the control panel so that it is outside the barrier area but located for an unrestricted view of the moving mechanism. The control panel must include an E-stop mechanism. Buttons that start the machine must be protected from accidental activation.
- Provide E-stop mechanisms located at the control panel and at other points around the perimeter of the barrier that will stop all machine movement when tripped.
- Provide appropriate sensors and interlocks on gates or other points of entry into the protected zone that will stop all machine movement when tripped.
- Ensure that if a portable control/programming device is supplied (for example, a hand-held operator/programmer pendant), the device is equipped with an E-stop mechanism.

NOTE: A portable operation/programming device requires *many* additional system design considerations and safeguards beyond those listed in this section. For details, see the safety standards specified by the governing authority (for example, ISO, OSHA, UL, etc.) for the site where the machine is being installed and operated.

- Prevent contact with moving mechanisms (for example, arms, gears, belts, pulleys, tooling, etc.).
- Prevent contact with a part that is thrown from the machine tooling or other part-handling equipment.
- Prevent contact with any electrical, hydraulic, pneumatic, thermal, chemical or other hazards that may be present at the machine.
- Prevent unauthorized access to wiring and power-supply cabinets, electrical boxes, etc.

- Provide a proper control system, program logic and error checking to ensure the safety of all personnel and equipment (for example, to prevent a run-away condition). The control system must be designed so that it does not automatically restart the machine/system after a power failure.
- Prevent unauthorized access or changes to the control system or software.

Documentation and Training

It is the responsibility of the machine/system designer to provide documentation on safety, operation, maintenance and programming, along with training for all machine operators, maintenance technicians, programmers, and other personnel who may have access to the machine. This documentation must include proper lockout/tagout procedures for maintenance and programming operations.

It is the responsibility of the operating company to ensure that:

- All operators, maintenance technicians, programmers and other personnel are tested and qualified before acquiring access to the machine or system.
- The above personnel perform their assigned functions in a responsible and safe manner to comply with the procedures in the supplied documentation and the company safety practices.
- The equipment is maintained as described in the documentation and training supplied by the machine/system designer.

Additional Equipment and Considerations

The Risk Assessment and the operating company's standard safety policies will dictate the need for additional equipment. In general, it is the responsibility of the operating company to ensure that:

- Unauthorized access to the machine is prevented at all times.
- The personnel are supplied with the proper equipment for the environment and their job functions, which may include: safety glasses, hearing protection, safety footwear, smocks or aprons, gloves, hard hats and other protective gear.
- The work area is equipped with proper safety equipment such as first aid equipment, fire suppression equipment, emergency eye wash and full-body wash stations, etc.
- There are no modifications made to the machine or system without proper engineering evaluation for design, safety, reliability, etc., and a Risk Assessment.

Safety Information Resources

Additional SmartMotor safety information can be found on the Moog Animatics website; open the topic "Controls - Notes and Cautions" located at:

<https://www.animatics.com/support/downloads/knowledgebase/controls---notes-and-cautions.html>

OSHA standards information can be found at:

<https://www.osha.gov/law-regs.html>

ANSI-RIA robotic safety information can be found at:

<http://www.robotics.org/robotic-content.cfm/Robotics/Safety-Compliance/id/23>

UL standards information can be found at:

<http://ulstandards.ul.com/standards-catalog/>

ISO standards information can be found at:

<http://www.iso.org/iso/home/standards.htm>

EU standards information can be found at:

http://ec.europa.eu/growth/single-market/european-standards/harmonised-standards/index_en.htm

Additional Documents

The Moog Animatics website contains additional documents that are related to the information in this manual. Please refer to these lists.

Related Guides

- Moog Animatics SmartMotor™ Installation and Startup Guides
<http://www.animatics.com/install-guides>
- *SmartMotor™ Developer's Guide*
<http://www.animatics.com/smartmotor-developers-guide>
- *SmartMotor™ Homing Procedures and Methods Application Note*
<http://www.animatics.com/homing-application-note>
- *SmartMotor™ System Best Practices Application Note*
<http://www.animatics.com/system-best-practices-application-note>

In addition to the documents listed above, guides for fieldbus protocols and more can be found on the website: <https://www.animatics.com/support/downloads/manuals.html>

Other Documents

- SmartMotor™ Certifications
<https://www.animatics.com/certifications.html>
- *SmartMotor Developer's Worksheet*
(interactive tools to assist developer: Scale Factor Calculator, Status Words, CAN Port Status, Serial Port Status, RMODE Decoder and Syntax Error Codes)
<https://www.animatics.com/support/downloads/knowledgebase.html>
- *Moog Animatics Product Catalog*
<http://www.animatics.com/support/moog-animatics-catalog.html>

Additional Resources

The Moog Animatics website contains useful resources such as product information, documentation, product support and more. Please refer to these addresses:

- General company information:
<http://www.animatics.com>
- Product information:
<http://www.animatics.com/products.html>
- Product support (Downloads, How-to Videos, Forums and more):
<http://www.animatics.com/support.html>
- Contact information, distributor locator tool, inquiries:
<https://www.animatics.com/contact-us.html>
- Applications (Application Notes and Case Studies):
<http://www.animatics.com/applications.html>

Grounding, Shielding and Noise Reduction



DANGER: The design/implementation of grounding, shielding and other noise-reduction methods will be driven by the Risk Assessment and the safety standards specified by the governing authority (for example, ISO, OSHA, UL, etc.) for the locale where the machine is being installed and operated. For more information, see Safety Information on page 9.

This section provides information on proper grounding, shielding and noise reduction best practices.

Causes of Noise	16
Ground Loops	16
Avoid Communications Ground Loops	16
Avoid I/O Ground Loops	17
Star Grounding	18
Shielded Cables	19
Drain Wire	20
Ferrite Beads (Chokes)	20
Noise Filtering	21

Causes of Noise

There are various ways that noise can get into the system. For example, unshielded or improperly shielded cables, bundling signal cables alongside high power cables, running signal cables near electrically "noisy" equipment, improper grounding techniques, etc.

The remaining topics in this chapter describe design techniques used to reduce or eliminate any unwanted noise from the system.

Additionally, watch the following video on our YouTube channel:

SmartMotor Hardware, Medical Apps and Electrical Interference

<https://www.youtube.com/watch?v=Ny0ztLiOGSI>

Ground Loops

Ground loops are caused by points in an electrical circuit that are connected by a conductor, and should be at the same electrical potential but are not. The difference in the electrical potential can induce unwanted noise (interference) into the system. In the case of a motion system, the unwanted noise can produce erratic or unpredictable behavior.

Avoid Communications Ground Loops

When multiple devices exist within the same system, they often need to communicate with each other. For signal connections to be made, it is often necessary for the devices to also share ground connections. This can create problems when these devices are operating from different power supplies and those supplies are connected to power sources referenced to differing potentials. Current can actually flow from one ground connection to another, which causes the resistance in the wiring to allow the current to flow and voltage to drop.

Isolation is the solution to these problems. Power can be isolated with transformers and signals can be protected with, among other things, opto-isolators. For example:

- Isolating the ground prong of the host PC for a single motor application is the simplest way to avoid a ground loop and associated damage. Unfortunately, this requires that the application has only a single axis. In a multiple-axis application, the issue of isolating each axis from the other still exists.
- Isolating the motor's power supply for a single motor application is another way to avoid ground loops.

NOTE: This only applies to very simple applications. Most power supplies either completely isolate the output from the input, or at least offer that provision.

If isolation is done, it is necessary to directly connect the host device to the SmartMotor. For example, avoid taking Transmit and Receive from the motor, but ground from the power supply. This mistake would expose the host computer to voltage spikes across the SmartMotor's power supply ground wire. If the motor's power is isolated, it should be enough to run the host device's Transmit, Receive and Ground wires directly to the associated pins on the SmartMotor's main connector.

- Using a communication isolation product to protect each axis in multiple axis applications is one of the best solutions. Moog Animatics has these devices available; they are designed to be very simple and effective solutions. More information is available on the Moog Animatics website at: <http://www.animatics.com>.

- Operating small wattage SmartMotors, such as a size 17 or 23 frame, at low power can eliminate ground "bounce". If this is the case, then interfering electrical noise, one of the two problems associated with isolation, is averted. The other problem with a ground loop is that two devices connected to the loop may be at different potentials. For example, if a host PC is connected to a power source that exists, for whatever reason, at a different level than the SmartMotor's power supply, large currents will flow through the ground wires.

NOTE: A warm or melted RS-232 cable is a sure sign that this problem exists!

Isolating the host device or power supply can solve this issue. Further, the fact that the motors are small and don't draw much current can solve the issue of electrical noise without isolating each and every axis. Greater success with this approach can be achieved by using very heavy gauge (-14) ground wire from motor to motor.

NOTE: Operating without isolation in the communications when using small motors, but at maximum torques, will probably not work reliably.

- Using no serial communications makes isolation of the communications a moot point.

Avoid I/O Ground Loops

The SmartMotor's I/O is TTL level (0 to 5V) and can be damaged if not used properly. Each I/O point has multiple functions. All I/O points enter the CPU in two places: one as a digital input, and another as an analog input. This means that no matter how you are using the I/O point, you can read back the analog value and learn a lot about how it is performing. For example, if the Class 5 D-style inputs 5 and 6 are being used as an RS-485 port, the analog reading capability can reveal whether the signals are properly biased when inactive. Refer to the following Class 5 D-style internal port schematic to predict how that SmartMotor's I/O may influence external circuits.

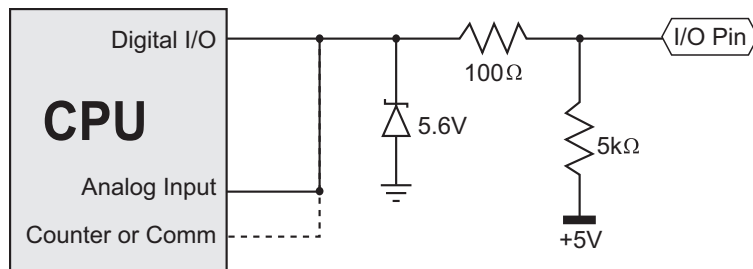

Knowing the SmartMotor's internal schematic can be useful when designing external interfaces. SmartMotor I/O is logic 0 for voltages below 1.2V and logic 1 for voltages above 3.0V. Note that logic states for voltages between these are unpredictable.

NOTE: For the Class 5 D-style SmartMotor, this schematic diagram applies to ports 0-3 and 6; ports 4 and 5 do not use the 100 ohm resistor.

Input impedance for these Class 5 D-style ports is 5 kohms. Input impedance for Class 5 M-style, Class 6 M-style and Class 6 D-style is 10 kohms. Refer to the corresponding Connector Pinout table in the *Moog Animatics SmartMotor™ Installation Guide*.

- For the Class 5 D-style SmartMotor, using the main or 5V power at the motor to operate any sensors is the best way to eliminate ground loops from I/O. That is why the power is there. If power goes from the SmartMotor's I/O connector to the sensor and the signal comes back, then there are no ground loop issues. In rare applications where the sensor cable travels a long distance through an electrically noisy environment, there may be a noise issue to contend with. Even still, proper shielding would most likely address this issue without engaging further circuitry for the purpose of isolating the signal. If the sensor requires 24 Volts rather than 5 Volts and a 5 Volt alternative is not available, then this can be solved by operating the SmartMotor at 24 Volts and pulling power for the sensor at the motor. When that option is not available, another one must be selected.

NOTE: If a signal is coming from another motor or PLC instead of a sensor, then that solution does not apply.

- Using an opto-coupler to interface to the inputs or outputs involves a few parts, but solves the problems of ground loops and electrical noise.
- Using an I/O isolation product is a simple and clean way of solving the problem of isolation.

NOTE: The Moog Animatics OPTO2 isolating I/O product can be found in the Product Catalog. It offers the additional benefit of interfacing 24 Volt I/O to the SmartMotor's I/O.

- Operating size 17 or short-stack 23 motors at low power can create an environment where the TTL signals of the SmartMotor's I/O connector are adequate. The I/O signals can travel short distances, ten feet or less, from motor to motor without a problem, provided the cables are thoroughly shielded. Greater success with this approach can be achieved by using very heavy gauge (-14 gauge) ground wire from motor to motor.

NOTE: Operating without I/O isolation when using small motors at maximum torques will likely not work reliably.

- Using no I/O connections removes the need for isolation.

Star Grounding

Star grounding (also called single-point grounding) is a common technique for minimizing ground loops and system noise. In this method, all equipment is tied to a common ground point. Refer to the following figure.

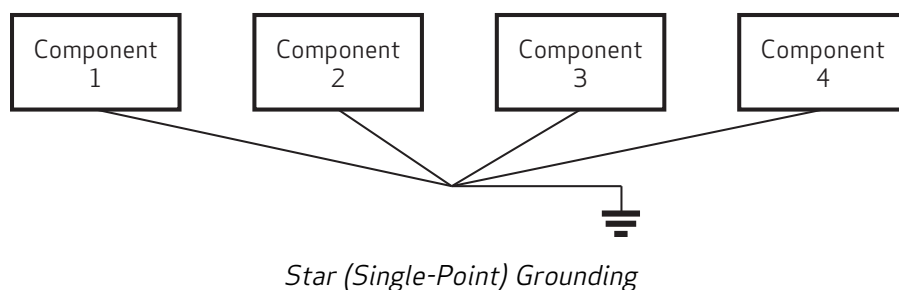

In some applications, where it is not practical to run individual ground wires directly to the common point, a bus bar can be used to carry the ground of several components to the common ground point. Refer to the following figure.

Shielded Cables

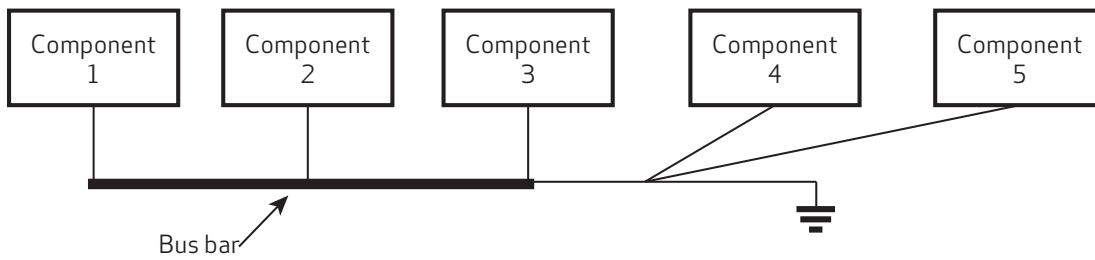

Star Grounding with Bus Bar



DANGER: For applications where the component's chassis must be grounded, there should only be one ground connection. DO NOT use the chassis as a ground conductor.

Shielded Cables

To minimize the possibility of electromagnetic interference (EMI), all communication lines should use shielded cables. The shield must fully encapsulate the internal signal wires, as shown in the following figure. The shield is typically at the outermost layer of the cable's internal components, located just under the cable jacket.

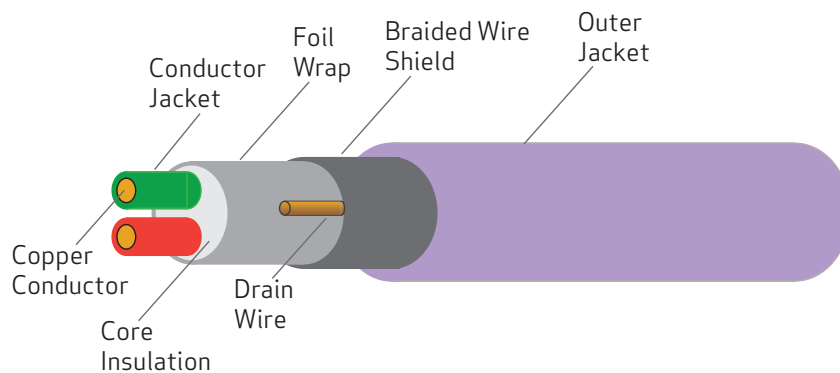

Cross-Section of a PROFIBUS Signal Cable

In low-frequency applications such as I/O or encoder signals or RS-232/485 or even CAN, (i.e., <1 MBaud), the "shield" is meant to protect the center conductors from outside interference. This is unlike coaxial (high frequency) cables, where the difference between the shield and center single conductor is actually part of the overall signal being transmitted.

NOTE: PROFIBUS goes beyond 1 MBaud and up to 12 MBaud. As a result, those installations must use coaxial cable, and shields are carried through and used as part of the signal path with the drain wire connected at both ends. The purpose of this is to shield lower-frequency signals.

In contrast, shield techniques change when you go to very high frequencies such as cable TV and cable internet. In those cases, shields are tied to ground at each end, and the cable is essentially a long coaxial capacitor. The signal is transmitted as a voltage across the capacity and sensed by receivers at any point on that capacitive cable.

Shields should be around the actual signal pair of conductors. The pair is most often twisted pair. The reason for the twist is to give equal opportunity for noise emissions to act on both conductors, so that the differential voltage between them remains the same regardless of that noise. The shield is to protect against excessive noise beyond which any inner conductors could handle.

NOTE: Any induced noise onto a conductor will produce some amount of current flow, which causes either addition or subtraction to the actual signal current flow.

By shielding the inner conductors from the induced noise, the noise produces current flow only onto the shield. This current then needs to be drained off to ground, but only to one end of the shield, not both. Otherwise, induced noise may spuriously flow to and from each end causing uncommon current flow induction into the inner conductors— they would then carry that noise with the signal, and the signal integrity would be lost. Refer to the following example figures.

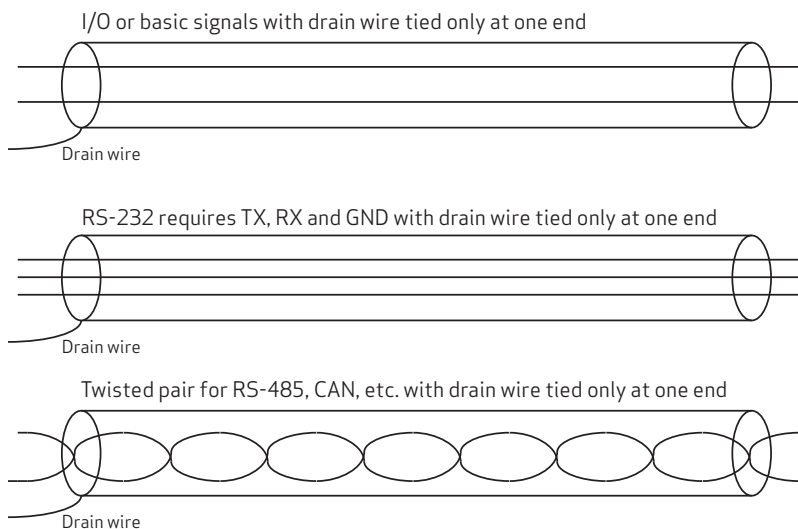

Shielding and Drain Wire for Different Signal Types

Drain Wire

The shielded cable should have its drain wire (see the previous figure) tied to the ground point at the end of the cable nearest to the signal source or power-supply source only. This helps to minimize switching regulator noise from the motor or switch-mode power supply.

NOTE: All frequencies related to the installation and operation of the SmartMotor are relatively low frequencies, which have less-stringent requirements.

For SmartMotor applications using RS-232, RS-485, and CAN, which are low frequency (limited to 1 MBaud), the drain wire is only needed to "drain" noise off to one end, not carry it through to the other end as a coaxial cable would. Refer to Shielded Cables on page 19.

NOTE: PROFIBUS goes beyond 1 MBaud and up to 12 MBaud. As a result, those installations must use coaxial cable, and shields are carried through and used as part of the signal path with the drain wire connected at both ends. The purpose of this is to shield lower-frequency signals.

Ferrite Beads (Chokes)

For certain types of signal wires, such as signal cables for computers and other sensitive equipment, ferrite beads (or chokes) are useful for reducing RF and digital noise. Refer to the following figure.

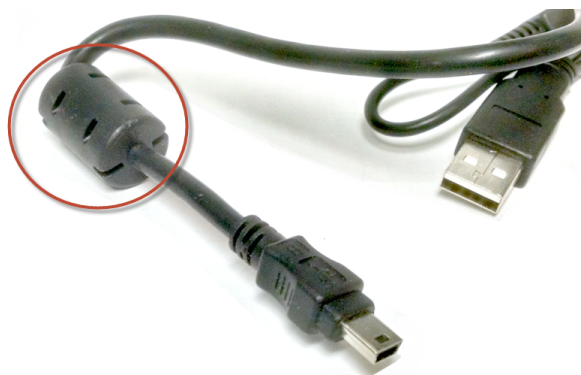

Ferrite Bead (Choke) on Mini-USB Cable

Typically, off-the-shelf cables that require a ferrite bead have it molded in (see the previous figure). However, snap-on and clamp-on ferrite beads are also available for use on custom cables, or if required as an add-on due to a specific application.

When selecting a ferrite bead, consideration must be given to the:

- Condition being corrected (transmission or reception),
- Frequencies that need to be attenuated,
- Size of the bead, and
- Materials used in the bead construction.

Noise Filtering

The following bullets describe scenarios where noise filtering may be needed to ensure a robust and reliable system. These examples refer to the Class 5 D-style SmartMotor.

NOTE: On the Class 5 D-style SmartMotor, ports 0, 1, 2, 3 and 6 are all classified as high-speed inputs.

- **Ports 0 and 1:** Ports 0 and 1 may be configured as Phase A and B encoder input or Step and Direction input. To ensure proper operation when following external encoders, it is strongly advised to use Line Driver encoders or encoders with true push-pull drive capability. This allows up to 1.5 MHz input frequency. Open Collector output encoders will not work above 20 kHz or so, typically due to the inability to properly drive input capacitance.
- **Ports 2 and 3:** Both Ports 2 and 3 default as Overtravel Limit inputs. They can be triggered by a negative edge transition as fast as 5 microseconds allowing optimum fail-safe detection of overtravel. However, noisy systems may require capacitive filtering to prevent false triggers from static or other induced noise.
- **Port 6:** Port 6 defaults as the “sync” or synchronous trigger input. This means any time it goes low, the processor issues a “G” command. The purpose of this is to allow precondition setup of motion profiles, and then, via hardware input, the user may synchronize multiple motor/axis starts at the exact same time. However, similar to the Overtravel Limit inputs, Port 6 can detect input pulses down to 5 microseconds. To ensure no false triggers, some system installs may require capacitive filtering to avoid false triggers.

In all cases above, typical filtering is done with 10 to 100 picofarad ceramic capacitors tied from the input pin to ground. This is only a recommendation; system characteristics may vary depending on surrounding equipment.

Communications

This chapter discusses the most popular communication methods. Each has its own set of electrical characteristics, which may reflect differently on issues or problems that may need to be addressed in the system design. The purpose of this chapter is not to cover intricacies of these protocols, but to provide awareness of cable issues and/or electrical issues.

Additional information, such as communication cabling and proper termination (when needed), can be found in the installation guide for each type of SmartMotor, the *SmartMotor Developer's Guide*, and also in the fieldbus guide for the corresponding protocol.

RS-232 Communications	23
RS-485 Communications	23
RS-422 Communications	23
CAN Bus Communications	23
PROFIBUS Communications	25
Ethernet Communications	25
USB Communications	25

RS-232 Communications

RS (Recommended Standard) 232, or RS-232, refers to serial ASCII-set bus protocol. It is an older communication method and yet still very reliable. It is a "full duplex" communications standard, meaning you can have a single device separately transmitting and/or receiving at the same time.

The SmartMotor incorporates RS-232 ECHO capability to support daisy chain operations. As a result, each motor brings a "fresh clean" source signal from its transmit port out to the next motor. There is no accumulated effect of parallel buses and no bus biasing is required. True RS-232 is a logic level swing between -12 and +12 VDC. This is up to 24V rail difference between logic states of ASCII data. As a result, RS-232 has been used to transmit over great distances. And, given that it is received by only one receive port, there is very little "buss loading".

RS-232 is quite robust for most applications. However, RS-232 is "single ended", meaning there is only a single-wire conductor referencing the signal to a ground reference that is common to all nodes. For long distances between multiple motors, RS-232 voltages move closer to ground, and ground moves closer to the signal, as distance from the source increases. This may open up system cabling for ground loops. Therefore, care should be taken to avoid non-star-grounded systems. For more information on ground loops and ground methods, see Grounding, Shielding and Noise Reduction on page 15.

RS-485 Communications

RS-485 is a "half duplex" bus and, therefore, cannot transmit and receive at the same time. For any given device, it must either be transmitting or receiving but NO two devices may be transmitting at the same time. Doing so would cause immediate loss of data.

RS-485 is a parallel bus structure employing a differential signal between a "high" and "low" side wire. All SmartMotors or nodes on the bus are in parallel, and logic would tell us they would see the same voltage differential. This is true except in cases where bus loading occurs or ground references shift due to high current draw of motors downstream of the power supply.

RS-485 is a 5V differential logic level. However, the actual voltage differential required is only 400 millivolts. This differential reverses or "flips" to change between logic level zero or 1. For a device or node to be in the "read" state, the high side wire must be ≥ 40 millivolts above the "low side" wire. This is considered an idle state and a state where any device would be listening for incoming data. If proper bus biasing is not used, and the 400 millivolts specification is not met, it could result in loss of data in one or more nodes on the bus.

The following are common causes of issues with RS-485:

- Improper biasing
- Not providing a unique address to each device ahead of time
- Too many devices on the bus (64 or less is best)

RS-422 Communications

RS-422 is essentially two RS-485 busses running together: one is set up to transmit, and the other is set up to receive. In that regard, it acts similar to an RS-232 system because it is full duplex, but it adds the advantage of differential signal. However, RS-422 does require proper biasing per the RS-485 specifications. Therefore, all pros, cons and considerations of RS-485 also apply to RS-422.

CAN Bus Communications

NOTE: Cable length, baud rate, bus layout and terminations are critical for proper CAN Bus communications. For details, see the *Class 5 SmartMotor™ CANopen Guide*.

CAN bus is a parallel bus structure employing a system of dominant and recessive signals. It is not fully differential in the way RS-485 is. This allows for an arbitration mechanism for multiple devices transmitting based on message identifier (which usually includes the CADDR address of the motor).

For proper CAN bus communications, each motor must be set to a unique address using the CADDR command. This will ensure that when two devices attempt to transmit at the same time, one will take priority. It is also essential for each device to have a unique address so that commands are directed to the correct motor.

Further, the baud rate must also match on all devices on the network. The default baud rate is 125000 on the SmartMotors. The motor's current baud rate setting can be checked using the RCBAUD command. It can be changed, if needed, and stored in EEPROM using the CBAUD command.

NOTE: Power should be cycled on the motor after a baud rate change.

CAN must be terminated at both ends of the bus with a terminating resistor between the CAN high and CAN low signals (120 ohms for each, typically). There should be a terminator at each of the two extreme ends of the bus—exactly two—no more, no less. If the layout of the bus cables doesn't accommodate this, then the layout is incorrectly designed.

A star, branch, or tree layout is not recommended for CAN bus communications. While it is possible to function this way, anyone who attempts this does so at their own risk and may experience communication failures depending on the length of branches, location of terminations and baud rate. The most effective thing to do is to maintain a linear single-line bus layout. The Y cables are intended to provide a limited amount of drop cable length to each motor. Do not add length to this drop or branch from it. The total amount of drop lengths can add up and eventually limit network performance.

A minimum cable distance between motors of 0.1 meter (4 inches) is recommended. A shorter distance could cause interference between motors.

For more information, see the *Class 5 SmartMotor™ CANopen Guide*.

PROFIBUS Communications

NOTE: Cable length, baud rate, bus layout and active terminations are critical for proper PROFIBUS communications. For details, see the *Class 5 SmartMotor™ PROFIBUS Guide*.

PROFIBUS is a "half duplex" bus and, therefore, cannot transmit and receive at the same time. For any given device, it must either be transmitting or receiving. NO two devices may be transmitting at the same time, as doing so would cause immediate loss of data. PROFIBUS manages this conflict with a bus controller¹ that directs the transmission of each device so that no two devices are transmitting simultaneously. Further, PROFIBUS requires that each motor is set to a unique address using the CADDR command. It is essential for each device to have a unique address so that commands are directed to the correct motor.

PROFIBUS is a parallel bus structure employing RS-485 differential signal between a "high" and "low" side wire. All SmartMotors or nodes on the bus are in parallel, and logic would tell us they would see the same voltage differential. This is true except in cases where bus loading occurs or ground references shift due to high current draw of motors downstream of the power supply.

As a result, PROFIBUS requires active termination at both ends of the bus. Without proper termination at both ends, there is a high likelihood of losing data packets. PROFIBUS cables often have the option to enable the termination that is built into the connector.

Further, PROFIBUS runs at substantially higher baud rates than RS-232, RS-485 or RS-422. As a result, cable length may be a larger issue. The higher the bus speed, the lower the effective wave length of the signal. If the signal wave length becomes a low harmonic length or longer length than the cable length between nodes, the chance of data loss increases drastically. Therefore, PROFIBUS should not be run at baud rates at or above 1 MBaud with cable lengths less than 1 meter. Doing so will increase the chances of data loss due to wave-length reflections on the cable.

For more information, see the *Class 5 SmartMotor™ PROFIBUS Guide*.

Ethernet Communications

Ethernet is the most reliable cabling system in that the signals are always fresh, point between two nodes only, and are all differential full-duplex signals. As a result, cables are rarely an issue, and proper communication typically comes down to IP and subnet addressing.

For cabling, the primary consideration is to use cables that are rated for the required speed. Cat5e cables are commonly used, low cost, and fully capable of 100Base-T communication speeds.

NOTE: If you have set your PC's network adapter to a fixed IP address for temporary connections to SmartMotors with SMI, remember to return it to DHCP when done to avoid local area network connectivity issues.

USB Communications

Presently, the one series of products that incorporate USB are the Class 6 M-Style SmartMotors. However, the USB port is only used for downloading and uploading programs, and for logging into a single node.

USB does not allow parallel bus. Further, for any given USB node, there must be a specific instance of software communicating with it. As a result, it is not suited for multidrop systems, and no motor-to-motor communications are possible.

¹Moog Animatics has replaced the terms "master" and "slave" with "controller" and "follower", respectively.

I/O

This chapter presents information related to I/O signals and protections.

Logic Level (5V TTL)	27
24V and Variations	27
AD1 Option	27
Higher Current Capacity I/O	28
Protections for I/O	28
External	28
Process, Power-Up Timing Methods	28
Analog Considerations	29
Encoder I/O, Single-Ended, Differential	29

Logic Level (5V TTL)

All 5V I/O is common grounded to system ground for control and drive power. As a result, caution should be taken to avoid voltage transients that could be imposed onto 5V inputs.

Each I/O point has 100 ohm series current limit resistor leading into a 5.6V shunt Zener diode. This helps to prevent overvoltage damage, but it does not prevent sustained spikes of more than 8 to 10 VDC. The result will cause the 5V I/O point to be damaged. All analog input signals route through a 10 kohm resistor to their respective CPU pin analog inputs and dedicated A/D converter. As a result, it is possible to lose digital I/O and yet still maintain the ability to read analog input.

When I/O has a 5 kohm pull-up resistor, it may skew analog input signals to the high side causing nonlinear results. Therefore, it may be necessary to place an external 5K pull-down resistor on the input to help balance the analog signals.

The I/O, when used as outputs, can actively drive 25 mA of current high to 5V or low to ground. As a result, when used as an output, the processor will not see much of a difference. However, if you have a channel assigned as an output and driving a signal into a high impedance input devices, the 5K pull-up resistor may cause leakage current to make the output state appear always high. Therefore, it is best to consider what type of inputs external devices may have. It is best to use those that require sinking to ground to prevent leakage currents from giving false-positive signals.

This same principle may apply to signals coming into a 5 volt channel. When using open, dry-contact switches, they MUST be wired into the motor input as sinking outputs in order to pull down the 5K pull-up resistor biasing in the motor. This means if you buy 5V sensors, they must be NPN (not PNP) type sensors. NPN sensors sink voltage to ground and will work with the 5K pull-up resistor. PNP sensors will not work.

24V and Variations

AD1 Option

This AD1 option currently runs a dedicated 16-channel chip with two sets of six channels run in parallel and the other four as single, direct channels. Each channel is capable of sourcing supply voltage up to 150 mA continuously. Six user channels incorporating parallel channels can source 300 mA continuously. All channels may source to loads at full continuous rating with no issues.



WARNING: The 42V in the following paragraph is a reference value only! It DOES NOT imply that 42V should be applied to an input. Exceeding the specified input voltage will damage the chip set and void the motor warranty.

Internal to the chip set is a single 10-bit A/D multiplexed to all channels of I/O with an internal 42V reference and 5V reference firmware selectable. This allows 10 bits of A/D data over 'zero to 5V' or 10 bits over 'zero to rail' supply voltage with those 10 bits referenced to the internal 42V reference. This also means the A/D *will not* achieve full 10 bit resolution with analog values of less than 42V. Therefore, some calculations must be performed to find the resolvability for the 42V reference.

Suppose an analog pot is feeding in 24 VDC to the I/O. To calculate the maximum A/D resolvability: $24/42 * 1023 = -585$ max raw binary value.

The increments are reported in millivolts (mV) where the "scale of resolvability" is $42000/1024 = 41$ millivolt increments over the total range of analog values. Accounting for noise, expect no better than 80 millivolt resolution over the entire analog range when using the full-range method of reporting voltage.

The RINA command is used to report the mV based on the I/O input volts scale. For example:

Volts Scale	RINA Command**	millivolts (mV) Reported	Resolvability	Noise
*0-24 VDC	RINA(V,16)	0-24000 mV	41 mV	±41 mV
0-5 VDC	RINA(V1,16)	0-5100 mV	6 mV	±36 mV
0-0.6 VDC	RINA(V2,16)	0-610 mV	1 mV	±10 mV

*Recommended scale for greatest range of analog inputs.

**Refer to the RINA command in the *Moog Animatics SmartMotor™ Developer's Guide*

The I/O connector has 12 pins with 2 pins dedicated for supply voltage. It is marketed to and rated for standard 18V to 32V logic systems meeting the requirements of both 28V aviation and military I/O, as well as standard 24V I/O of industrial automation. Each channel incorporates a shunt diode for dealing with inductive loads. There is no pull-up resistor on any channel. All channels incorporate internal overcurrent protection that will result in an I/O fault state that must require power down to reset.



WARNING: At no time should a higher voltage than the specified supply voltage be placed on an input! This could cause immediate damage to the chip set and void the motor warranty.

At no time should a higher voltage than the specified supply voltage be placed on an input! This could cause immediate damage to the chip set. This is important to recognize in systems where sensors may get supply voltage from a separate source than is supplying the AD1 option. As a result, it is highly recommended to common source supplies for all I/O and the AD1 option. This will ensure the inputs would never supply voltage into the chip set while the chip is powered off.

Higher Current Capacity I/O

Class 5 and Class 6 motors with dedicated brake outputs may run brakes with up to 2 amps of current. This should handle any standard fail-safe electric brake within reasonable size for the torque of the associated motor. No external shunt diode is required. The output is fully protected. However, driving the output into a short may cause damage.

Some Class 4 and Class 5 motors have been sold with brake output boards but no brake. These brake outputs source 12 VDC at approximately 1.2 amps continuous. If they were to run into a short, the circuit would fold back to continuous current and could fail if sustained in that situation for very long. The brake output board operates very quickly and is firmware controlled by default. As a result, it may be used for high-speed triggering of external loads.

Protections for I/O

The following are protections for bus voltage fluctuations that can be provided through external devices or other methods.

External

Any inductive loads attached to the AD1 option should employ the use of shunt diodes. Although there are internal diodes at the chip level, they do not have the capacity of larger, fast-trigger, shunt diodes for large inductive loads. Over time, the internal diode may fail and result in loss of an I/O channel.

Process, Power-Up Timing Methods

As stated in the AD1 section, no I/O should supply an input voltage greater than the supply voltage. There may be a situation where timing relays are needed to ensure I/O devices do not receive power

until after the AD1 option connector has power. Otherwise, if a single power supply is used for all I/O devices and is within 18 to 32 VDC, then the system should respond well with no issues.

Analog Considerations

5V I/O has internal pull up resistors that may skew results of an analog input device. It is best to ensure analog signals can sink voltage down against the 5K pull-up resistor. Further, it may be required to add a 5K pull-down resistor to balance the signal.

The AD1-option I/O will lose A-D full-bit resolution across 0-24V or 0-10V analog signals when read as full-analog-input values. This is due to the 42 VDC internal reference. For details, see 24V and Variations on page 27

Encoder I/O, Single-Ended, Differential

The D15IOHSABLIM is an adapter used to accept differential 5V TTL encoder signals and pass them into the motor's single-ended 5V I/O (first two channels for encoder input). It incorporates high-speed HP digital optocouplers for speeds greater than 1 MBaud. As a result, just about any differential 5V quadrature linear or rotary encoder will work well with no noise issues. The adapter also includes two travel-limit inputs for 24V signals. They are also differential and allow for NPN or PNP signals.

Otherwise, if the adapter is not used, a standard push-pull TTL output quadrature encoder may be connected directly to the encoder input. You may chose +A and +B, or -A and -B, if they are true push-pull outputs.

Power-Up Management and E-Stop



DANGER: The design/implementation of barriers, emergency stops (E-stops), power shutoff mechanisms and other safeguards will be driven by the Risk Assessment and the safety standards specified by the governing authority (for example, ISO, OSHA, UL, etc.) for the locale where the machine is being installed and operated. For more information, see Safety Information on page 9.

This section provides information on power-up management, E-stop, and related topics.

Power Supply	31
Compute the Required Current	31
Fuse the Connection	31
Select the Proper Supply Type	31
Operate at or below 48 VDC	32
Other Considerations	32
Comparison between Linear and Switching supplies	32
What concerns are there with maximizing voltage on the supply?	34
How do I size power supplies?	34
Changing Input Voltage on Open Frame Power Supplies	35
Bus Voltage Fluctuations	36
Causes	36
Protections	36
External Devices	36
Process, Power-Up Timing Methods	36
Disconnecting Power	37
Control Power Switch	37
E-Stop Switches	37
Using Separate Drive and Control Power	37
DE Power Option	38
Shunts	40
Why Are Shunts Needed?	40
Back EMF and Regenerative Energy	40
Selecting the Correct Size Shunt	41

Power Supply

Properly selecting the power supply for your SmartMotor™ application is critical. Not having enough voltage and current may hinder the performance of the SmartMotor, resulting in excessive position errors, overcurrent warnings, etc. Having too much current go through the motor can also damage the circuitry. Therefore, it is important to follow these guidelines:

- Compute the Required Current
- Fuse the Connection
- Select the Proper Supply Type
- Operate at or below 48 VDC
 - Use a shunt near the motor, or
 - Add a shunt to a switching power supply, or
 - Operate at 42 VDC or less, and add a shunt for any vertical application

Compute the Required Current

There is a simple way to compute the required current for a given application. This is useful when choosing a power supply for a given application, but it is also useful when attempting to calculate how many motors can be powered from one supply in low-current applications. The peak current can be computed by taking the peak required torque (T_p) and dividing it by the torque constant (K_t) of the motor in question. Example: An engineer has decided on using an SM2337D SmartMotor ($K_t = 5.60$ oz-in/Amp), and has determined that 100 oz-in of peak torque is required for the application in question. The peak required current would be T_p/K_t , or $(100 \text{ oz-in}) / (5.60 \text{ oz-in/Amp})$, which amounts to 17.9 Amps.

Fuse the Connection

Each SmartMotor should have its power separately fused in a single, serviceable location. A slow-blow fuse rated above the continuous current requirement of the application will protect the motor under most circumstances, and yet survive the inrush current that occurs during power-up due to the SmartMotor's internal capacitance.

Select the Proper Supply Type

The SmartMotor is a switching device that uses PWM (Pulse Width Modulation) to regulate the power of the motor. Based on the application needs, the motor may be drawing just a few dozen milliamps one moment, and then a few dozen amps the next. It may even drive current back into the supply when it is decelerating an inertial load or lowering a heavy vertical load. The optimum power supply for a servo system is a simple transformer, rectifier and capacitor design, with no active components trying to regulate the voltage. A shunt may also be necessary, which is discussed later in this chapter.

Many applications benefit, however, from enjoying the smaller form-factor, lighter weight or greater availability of switching power supplies.



WARNING: If a SmartMotor draws an excessive amount of current from a non-regulated supply, the voltage will simply sag. However, if it draws even a bit more than the specification of a switching power supply, the power supply will "crowbar" (basically, completely letting go of the load at a time when power is needed the most). This will not only fail the application, but you might also damage the SmartMotor.

When sizing a switching power supply, you must be sure to size it for the maximum possible peak-current draw of the SmartMotor, not the expected continuous draw as you would with an unregulated supply.

When using a switching power supply, it is most desirable to operate the SmartMotor from a switching power supply that is loaded by many other constant-current devices, where the SmartMotor doesn't overwhelm the total power budget.

Also, it can be even more important to use a shunt (a device that burns off excess power resulting from motor back-drive) with a switching power supply for two reasons. First, because of its tight regulation, you may get a switching supply set to a voltage very near the SmartMotor's limit, leaving little budget for a voltage spike. Second, a switching power supply will not accept current driven back to the supply, so current sent back to the supply from a motor being back-driven will end up pouring charge into its own capacitors, and the small capacitance in the output stage of the supply, driving the supply voltage up beyond the SmartMotor's limit, causing damage.

Therefore, use a transformer-based power supply or pay close attention to properly sizing a switching supply to maximize the SmartMotor's industry leading longevity and performance.

Operate at or below 48 VDC

Overvoltage can occur due to voltage spikes entering the power supply, by abrupt decelerations of the motor with a heavy inertial load or by the back-driving of the motor due to a falling vertical load that changes the motor into a generator. Another common cause of overvoltage arises when the unloaded voltage level of a power supply goes overlooked. It is not uncommon, for example, for an unregulated "48 Volt" power supply to actually put out 55 Volts or more when unloaded, or lightly loaded, as would be the case of a SmartMotor that is not moving or holding. Operating at 42 VDC or less as nominal is an excellent way to help protect the SmartMotor from damage due to inadvertent overvoltage. Having the additional 6 Volts of headroom is usually enough to protect against all of these conditions, except for the falling vertical load.

Using a shunt near the motor provides the best protection for overvoltage arising from virtually any circumstance. The keyword is "virtually". As an example, 10 feet of 14 or 16 gauge wire is "near" the motor. 100 feet of wire, of any gauge, is far away. At this distance, the wire experiences a significant voltage drop when current flows and isolates the SmartMotor from the voltage protection that the shunt is supposed to offer.

Adding a shunt to a switching power supply will prevent at least one of the failure modes known to be associated with the use of switching power supplies in servo applications - back drive or "regeneration".

Operating at 42 VDC or less and adding a shunt for a vertical application is the safest way of handling voltage regulation problems. The added 6 Volts of margin combined with the shunt protection will maximize the reliability of the SmartMotor in an application that due to gravity or other influence, can be back-driven by the load itself.

For more details on shunts, see Shunts on page 40.

Other Considerations

Comparison between Linear and Switching supplies

Which type of power supply is better—Linear or Switching? This is more of an application-specific question.

Linear supplies are better suited for inductive loads. SmartMotor servos are inductive loads. Linear supplies can handle high current surges typically caused by starting and stopping of servo motors. However, linear supplies have what is known as voltage droop. This is characteristic of voltage dropping down with an increase in load. Typically, unregulated toroidal transformer supplies will drop 4 to 7%

and E-Core types (the big square transformers) are >10%. A linear supply only needs to be sized for continuous load. Linear supplies have a large capacitance to supply much higher current surges when needed. Refer to the following figure.

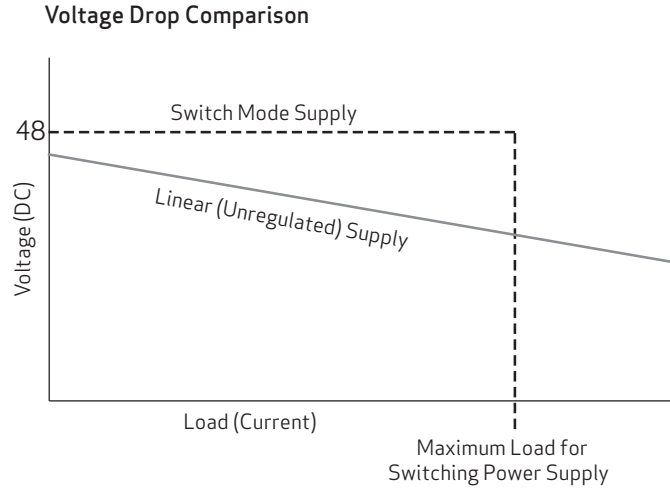

As shown in the previous figure, switching supplies (or switchers) have no voltage droop until they reach maximum load. Then they just drop completely to zero volts. Because they maintain a tight control over voltage up to the trip point, they can typically aid greatly in reaching maximum speed and acceleration of a given servo. However, the switching supply must be sized for the maximum expected peak current draw of the motor.



WARNING: The switcher supplies have an adjustable output trim pot. If used with our shunts, the output voltage **MUST** be adjusted to ≤ 48 VDC to ensure the shunts do not stay gated on.

The following chart gives a brief comparison of the two types of supplies.

Consideration	Linear	Switcher
AC Input	Field selectable (120/240 VAC)	Universal 90-240 VAC
Power Factor Corrected	No	Yes
Relative Size	Big and bulky	Lightweight
Cooling	Ambient convection	Fan cooled
Surge Capacity	400%	5%
Voltage Regulation	15% drop over range	0%, fixed
Shunt Required?	Occasionally, but not typically	In most cases, highly recommended!

What concerns are there with maximizing voltage on the supply?

The higher the voltage, the faster the SmartMotor can move and the faster it can accelerate. This is a good thing. However, in conjunction with this, the higher the voltage, the closer you get to a peak voltage that can cause overvoltage breakdown of the controller. Also, the higher the voltage, the faster a rate of change of current can occur. It is a risk with any application to get faster response by increasing the voltage. Typically speaking, it is the dynamics of sudden changes that increases risk by an "x²" factor; whereas, the continuous load risk is only a direct ratio increase. This is because rate-of-change in current is proportional to acceleration, which is the square of velocity (i.e., x²). For safety, a 42 VDC supply for a 48 VDC system gives good margin with little speed losses.

How do I size power supplies?

The quick answer is "more is better". First, be sure you have the correct SmartMotor for the job. Once that has been done, take the nominal power rating for that motor and you should size a *linear* supply to provide about 10% more power to allow for longer sustained current loads. Any *linear* supply will typically provide more than enough peak current.

However, this is where sizing gets tricky with switching power supplies. "Switchers" typically come with some rated voltage and current. For example, 48 VDC at 6 Amps. And, that is also the problem. In this example, the switcher can provide a steady 48 VDC all the way up to 6 amps; however, if any more current is applied, the power supply will drop out to zero VDC and typically reset. Any time you wish to use switchers, you need to take the peak expected load of the motor and size the switcher's continuous rating for that contingency. As a rule of thumb, any 23 NEMA frame SmartMotor can pull as much as 12 amps instantaneous. Most 23 frame SmartMotor servos will not pull more than about 9 amps instantaneous. A 10 amp switcher can supply any 23 frame SmartMotor for *most* applications. Whereas, a 34 frame SmartMotor will require a 20 amp continuous rating to be sure you will not get a tripped power supply. Keep in mind that a 34 frame SmartMotor can pull as much as 40 amps or more for a few milliseconds. Therefore, as originally stated, "bigger is better," especially when it comes to switchers.

For more information, watch the following video on our YouTube channel:

Sizing Power Supplies with Torque Curves and Efficiency Curves

<https://www.youtube.com/watch?v=eMGkUMyrRo4>

Changing Input Voltage on Open Frame Power Supplies

Moog Animatics offers open frame power supplies that are factory set for either 110/120 VAC or 220/240 VAC input voltage. However, all of the open frame supplies can be converted in the field for the desired input voltage (either 110/120 VAC or 220/240 VAC). Refer to the connector locations and schematics in the following figure for details.

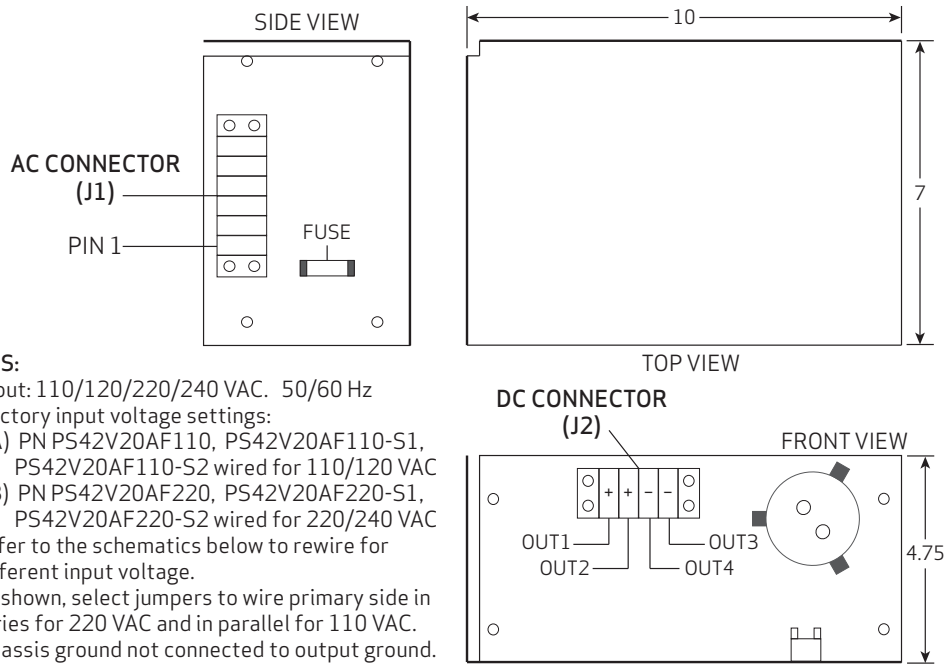

NOTES:

1. Input: 110/120/220/240 VAC. 50/60 Hz
2. Factory input voltage settings:
 2A) PN PS42V20AF110, PS42V20AF110-S1, PS42V20AF110-S2 wired for 110/120 VAC
 2B) PN PS42V20AF220, PS42V20AF220-S1, PS42V20AF220-S2 wired for 220/240 VAC
 Refer to the schematics below to rewire for different input voltage.
 As shown, select jumpers to wire primary side in series for 220 VAC and in parallel for 110 VAC.
3. Chassis ground not connected to output ground.
4. Dimensions are nominal. Units are Inches.
5. Some components omitted for clarity.
6. All mounting holes 10 - 32 thru.

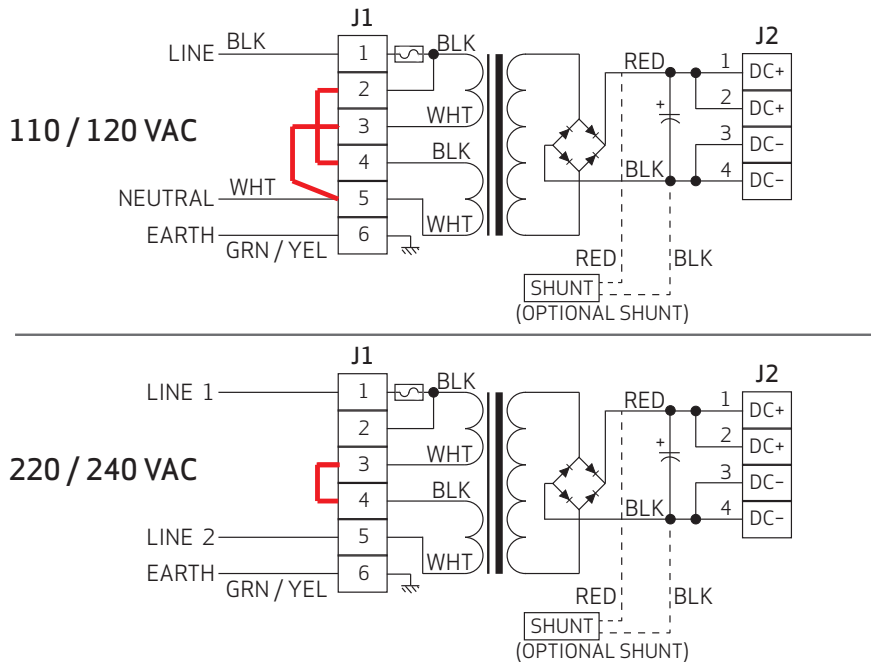

Open Frame Power Supply Connector Locations and Input Voltage Schematics

Bus Voltage Fluctuations

This topic describes problems that occur with bus voltage fluctuations.

When DC bus voltage fluctuates up or down, it may cause adverse effects to the SmartMotors or other equipment on the same bus.

Causes

The following are causes for bus voltage fluctuations:

- Low bus-voltage transients may occur when motors or other devices on the bus suddenly demand more current. If the gauge of the wire between the supply and load is too thin, there could be larger fluctuations due to VOLTAGE DROP
- High bus-voltage transients may occur from Back EMF (BEMF), regenerations, or "inductive kick" from other devices.

Protections

The following are protections for bus voltage fluctuations that can be provided through external devices or other methods.

External Devices

- Parallel bus shunts should be connected in a way that does not isolate them from the motor drive power input when power is disconnected for E-stop or guard door open reasons.
- Shunt diodes should be used for any inductive I/O loads. This includes valve coils, relays, solenoids, contactors or similar loads.

Process, Power-Up Timing Methods

- When separate drive and control power are used, drive power should be applied after control power and removed before control power. This allows proper control of the system for slowing down or stopping motion under E-stop conditions.
- Capacitance in the SmartMotor is NOT high enough to require resistor charge-up time with timing relays. It is not recommended to place any resistors in line with power.
- Under no circumstances should series diodes be placed in line with the drive power input. This would prevent Back EMF from having a means to dissipate power and result in high risk of damage to the motor electronics.
- A shunt diode could be placed in reverse parallel to the bus, but it would do little good because the SmartMotor drive stage already includes that feature.
- E-stop with the desired ability to stop quickly should also include dropping out of the travel limits to allow FSA (Fault Stop Action) options.

Disconnecting Power

This topic describes best practices for disconnecting power from the system. Whether there is separate drive and control power or not, the easiest way to interrupt power is on the AC side of a power supply. For more details, refer to the section Using Separate Drive and Control Power.

The remainder of this topic assumes that power is being interrupted on the DC side. For examples of the methods described here, refer to the DE Power Option Diagram on page 39.

Control Power Switch



CAUTION: When breaking the DC side of a power input, always break the high side of the circuit only! DO NOT break the low (ground) side of the circuit.

Control power switches should be wired to the system in a manner that allows them to break the Control power flow from the high side of the DC circuit. This leaves the low (ground) side of the circuit intact. Refer to the DE Power Option Diagram on page 39 for a schematic showing separate Control power.

E-Stop Switches



CAUTION: When breaking the DC side of a power input, always break the high side of the circuit only! DO NOT break the low (ground) side of the circuit.

Emergency stop switches should be wired to the system in a manner that allows them to break the Drive power flow from the high side of the DC circuit. This leaves the low (ground) side of the circuit intact. For an example E-Stop switch schematic, refer to the DE Power Option Diagram on page 39.

Using Separate Drive and Control Power

It is always best to use SmartMotors with separate Drive and Control power (Class 5 D-style SmartMotors that are equipped with the DE option, Class 5 M-style motors or Class 6 motors). Refer to the DE Power Option Diagram on page 39. If separate drive and control power are not present, then the motor will typically need to be re-homed after an E-Stop has been activated.

Whether there is separate drive and control power or not, the easiest way to interrupt power is on the AC side of the power supply. If there is a problem with the motor still moving as the power drops out, an I/O can be used on the motor to detect that the E-Stop was pushed, and then halt motion by programming an interrupt for that condition.

If it is desired to break power on the DC side, a shunt will need to be wired in the circuit so that the shunt stays with the motor, not the power supply. If there is a high inertia load, or rapid starts and stops, the shunt is recommended, even if the circuit is breaking power on the AC side, to protect the motor from its own Back-EMF (BEMF). For example, refer to the shunt wiring in the DE Power Option Diagram on page 39. Also, refer to the topic Shunts on page 40.

DE Power Option

This topic describes the DE power option, which is available for the Class 5 D-style SmartMotor.

NOTE: All M-style and IP-sealed SmartMotors are designed to always have separate drive and control power. Therefore, no DE designation is available for these SmartMotors.

The DE power option allows the controller and drive-amplifier to be powered from separate 24-48 VDC power supplies (see the following figure).

- Position will not be lost on loss of drive-power
- No need to re-home
- Load surges will not cause power surge on controller
- Standard battery options are made simpler

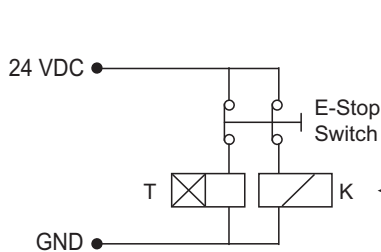
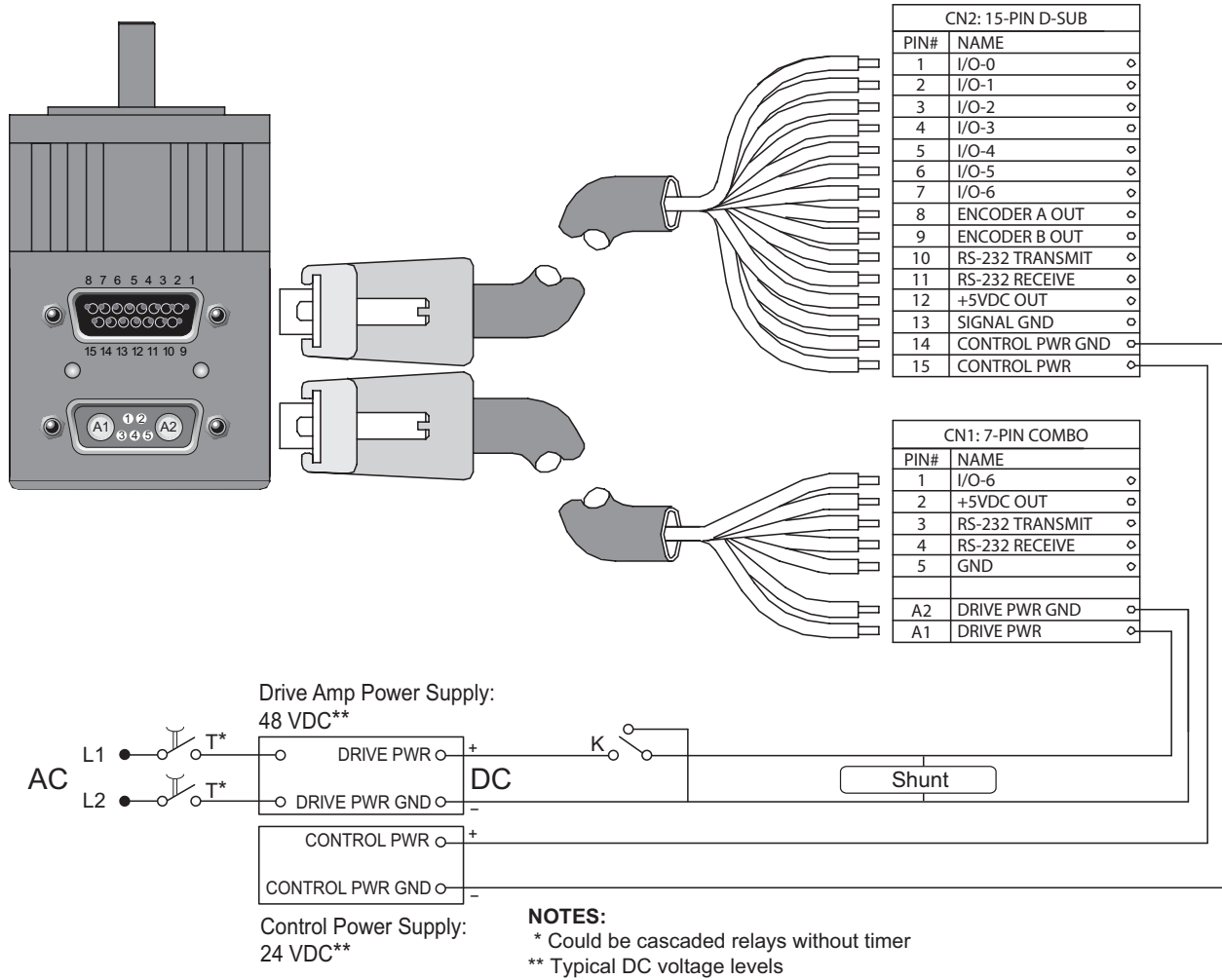

Protective shunt should be placed between E-stop and motor drive power input to suppress Back EMF.

Optional shorting of motor input on dropped drive power provides the most protection against Back EMF, and unintended freewheel motion, by employing dynamic braking to stop the motor.

Relay T is time-delay open; relay K is immediate open; relay K must close before relay T to avoid any damage to relay K from SmartMotor in-rush currents.

This circuit is recommended for smoother startup of large switch-mode supplies where surge currents may cause noise issues.

DE Power Option Diagram



WARNING: As shown, protective shunts should be placed between E-stop and motor drive power input to suppress back EMF!

Also, note that the above diagram is a suggestion for possible wiring of the DE option SmartMotor. The circuit shown is recommended to allow easier start-up of large switch-mode supplies where surge currents may cause noise issues. There are other ways to achieve this. However, keep in mind the following:

- The power supply MUST have an E-stop interrupt on the DC Link supply side or the AC side.
- Relay T is time-delay open; relay K is immediate open. Relay K must close before relay T to avoid any damage to relay K from SmartMotor in-rush currents.
- The E-stop immediately opens and shuts DC side, but the timer relay is a delay-on that causes AC to come up *after* DC. This allows the switch mode supplies that are not good at bringing on sudden load changes to come up slowly on their own, and bringing the load up with them.
- As shown, a protective shunt should be used between the E-stop and motor drive power input to suppress back EMF.

For more information, watch the following video on our YouTube channel:

DE Recommended Option for SmartMotors

<https://www.youtube.com/watch?v=DrMCJNP7Zwk>

Shunts

Moog Animatics offers several shunt options for use with DC input servo motors. This topic gives an overview of why shunts should be used in the machine design.

Why Are Shunts Needed?

Shunts are needed to protect the servo controller and drive stages from overvoltage. Overvoltage sources originate from the following:

- Regenerative energy
- Back EMF (or Counter EMF)
- Sudden or hard decelerations
- Hard stop crashes (immediate deceleration to zero speed)
- Vertical load drops

The shunts actually add an additional load to the DC bus automatically when voltage exceeds the trigger level by connecting large load resistors across the bus. Trigger voltage is typically 49.5 VDC. As a result, the shunts will work with any of the supplies offered by Moog Animatics.



WARNING: The switcher supplies have an adjustable output trim pot. If used with our shunts, the output voltage MUST be adjusted to ≤ 48 VDC to ensure the shunts do not stay gated on.

Back EMF and Regenerative Energy

Generally speaking, back EMF (BEMF), also referred to as counter EMF (CEMF), is the voltage generated in a motor when it spins. This voltage is typically proportional to speed. However, this is a general rule. The truth is that the BEMF voltage is proportional to the rate of change of magnetic flux in the windings of the stator. As a result, constant speeds produce constant and predictable voltages.

Further, when the motor's drive stage is opposing the mechanical energy (spinning inertia load) and decelerating the motor (and load) with opposing current, the mechanical energy is converted into electrical energy, which is generated or even forced onto the power supply. If this energy is not absorbed with bus capacitance or shunted away, it can cause serious failures of battery, power supplies, and most likely the SmartMotor.

Selecting the Correct Size Shunt

Also, a sudden dramatic drop in speed, for example, a hard-stop crash, causes an immediate change in magnetic flux or even a total instantaneous collapse. As a result, voltages can go 5 to 10 times higher than spinning the motor at its maximum speed. For this reason alone it is highly recommended to use a shunt in all vertical load applications or any case where the motors could be stopped quickly or back driven suddenly. Again, a shunt is needed to protect the motor and power supply.

Moog Animatics offers both open frame and enclosed shunts in 100 Watt and 200 Watt capacities. Refer to the following figure. The shunts are all automatic and get their power from the DC bus they are attached to. They simply need to be placed in parallel with the DC bus in order to protect both the motor and power supply.

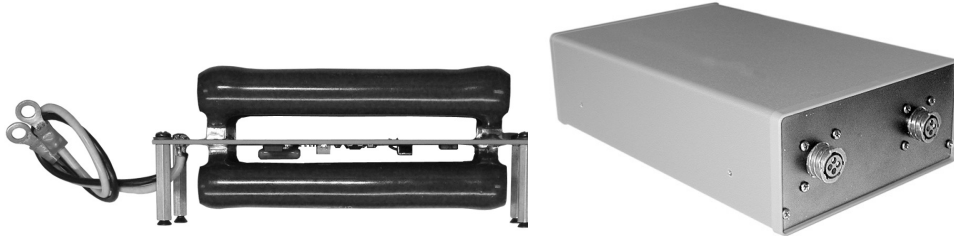

Open Frame and Enclosed Shunts



WARNING: Shunts should always be placed between the motor input and any disconnect or E-stop relay to ensure protection of the motor when power is not applied or E-stop relay contacts are open.

Having said all of that, BEMF and regenerative energy are not all bad. For example, for winding applications, Moog Animatics advises customer to use trajectory overshoot braking (TOB), which takes into account both BEMF and regeneration.

When TOB engages, it is due to the crossing point from BEMF over to regeneration. At that point, the SmartMotor engages a dynamic braking form of commutation in order to use regeneration to slow the overshoot in trajectory. It is easily detectable because it occurs at the point where the sign of the following error crosses zero. This is a very useful means to more accurately control the winding.

Selecting the Correct Size Shunt

Moog Animatics offers shunts in open and closed frame designs—both are available in 100 Watt and 200 Watt versions. In order to select the proper size, you must know the peak wattage of the motor, which is found on the motor's power curve chart.

For example, the SM23165D motor's power curve is shown in the following figure. From that, we see that the Peak Power is approximately 187 Watts. Therefore, you would need to select the 200 Watt version of the desired shunt type (open versus closed frame).

Also, as noted in the previous section, if you are using a switching power supply, you must adjust the output trim pot so the maximum output voltage is ≤ 48 Volts.

SM23165D at 48 VDC at rise to 85°C

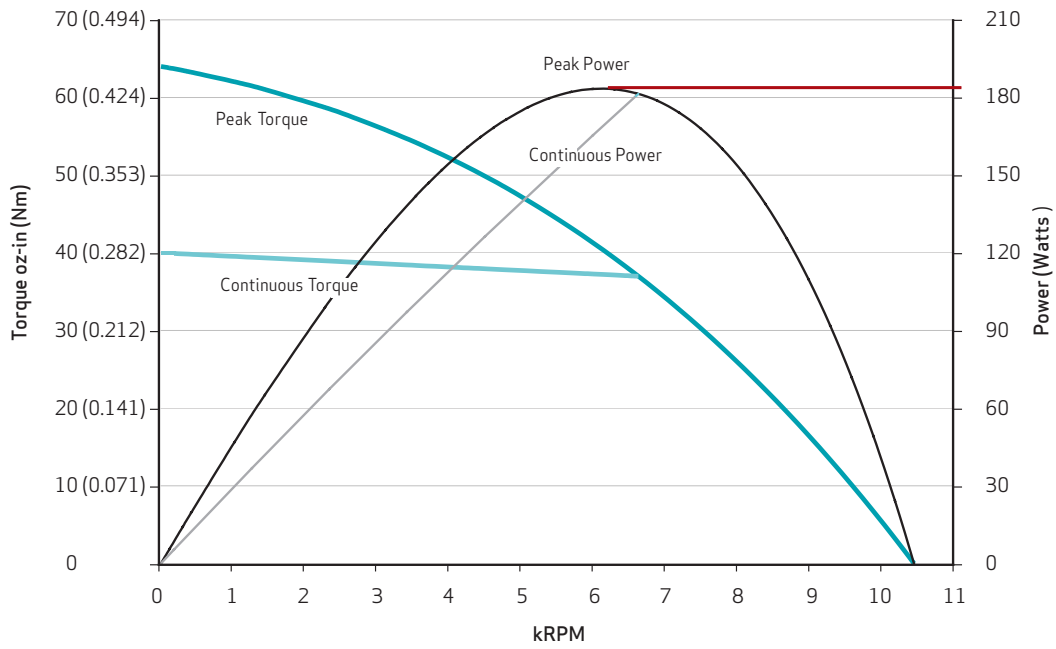

Gearheads

This chapter describes the non-captive gearheads, and provides general mounting procedure for any gearhead to prevent stress on the motor shaft.

Non-Captive Gearheads	44
Gearhead Torque Notes	44
Mounting Procedure for Non-Captive Gearhead	44
Gearhead Sizing Example	46

Non-Captive Gearheads

All Moog Animatics gearheads have a non-captive input pinion gear. This means that the pinion is mounted onto the motor shaft and the gearhead is then mounted onto the motor flange. See the following figure.

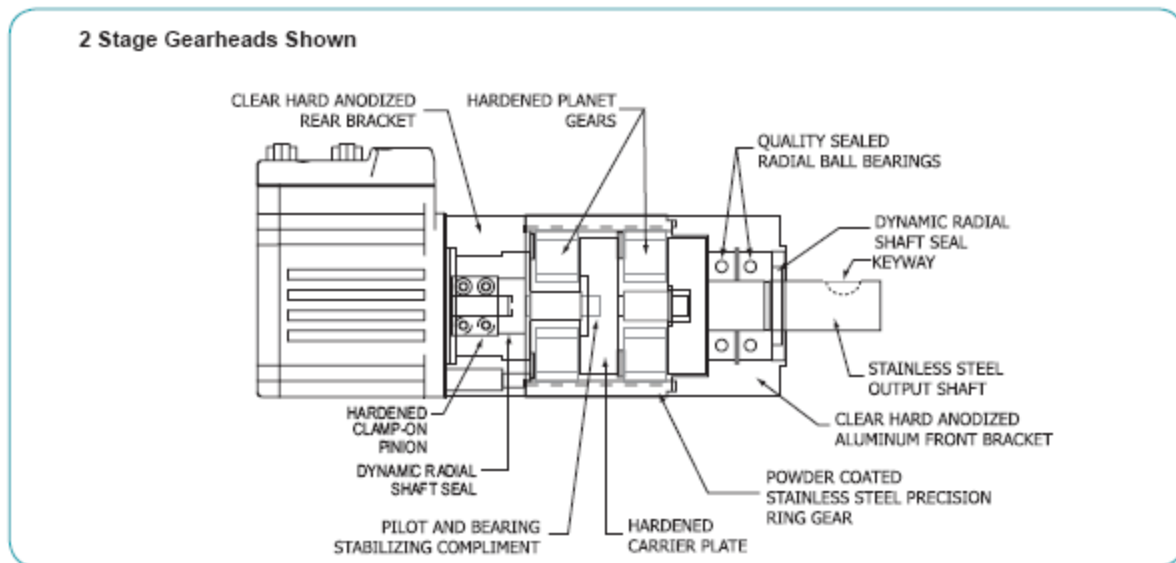

Gearhead Torque Notes

- Torque throughput on inline (straight) gearheads is limited by input pinion diameters.
- Typically, the 7:1 ratio single-stage and 28:2 ratio two-stage gearheads have higher torque ratings. Whereas, 10:1 and 100:1 gearhead input pinions are very small and have lower torque rating. Therefore, great care should be taken not to exceed maximum torque ratings for the latter gear ratios.

Mounting Procedure for Non-Captive Gearhead

The following items are included with your Moog Animatics gearhead:

- 1 pinion
- 1 or 2 hex wrenches
- 1 key
- 4 mounting screws
- 1 feeler gauge (optional)

Following the steps below, you will clamp the pinion to the motor shaft, then fasten the gearhead to the motor.

1. Remove the pinion or plug from the gearhead's input seal
2. Place the motor on a level surface if possible.

3. Insert the pinion onto the motor shaft. See the following figure. Space it according to the dimension "A" shown below.

Motor Size	Dimension "A"	Tolerance
NEMA17	1.50	+/- 0.025
NEMA23	1.44	+/- 0.025
NEMA34	2.01	+/- 0.025

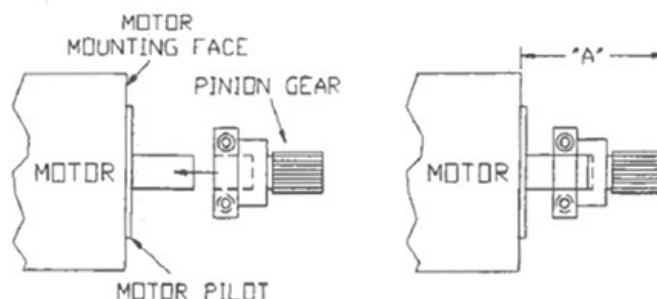

Mounting the Pinion Gear to the Motor Shaft

4. Tighten the pinion's clamping screws to the specifications listed in the following table.

Screw size (alloy steel)	Recommended torque (in-lbs)	Tolerance +/- (in-lbs)
4	15	3
6	25	5
8	45	10
10	66	13
1/4	115	15
5/16	175	20
3/8	250	25

5. Pick up the gearhead and very slowly and carefully insert it onto the pinion.



CAUTION: Keep the gearhead centered and parallel with the motor output shaft while assembling the gearhead to the motor.

NOTE: It may be difficult to get the gear teeth to line up and slip into place. DO NOT move the gearhead radially back and forth. If you are having difficulty sliding the gearhead onto the pinion, try turning the gearhead's output shaft back and forth. Keep the gearhead centered and parallel with the motor's output shaft.

6. Insert the gearhead mounting screws (thread locker is recommended), but do not tighten. With the mounting screws loose, turn the gearhead's output shaft. This helps the pinion center itself within the gearhead. Five to ten revolutions should be enough.
7. Tighten down the mounting screws to the specifications listed in the previous table.

Gearhead Sizing Example

Assume a customer has an application that needs 485 oz-in's at 223 RPM at the load. He wants to get the most effective use of a motor-gearhead combination.

First, maximize RPM into the sweet spot of any given motor:

- Run the gearhead at maximum continuous RPM input speeds
- Most gearheads are rated for ~4000 RPM

Therefore: $4000 \text{ RPM} / 223 \text{ RPM} = 17.9$

This means a 17.9:1 reduction would be ideal. However, most gearheads are available with reductions of either 16:1 or 20:1. In this case:

- 20:1 would be too much because the motor input speed would exceed 4000 RPM
- 16:1 would be the closest

Therefore, for speeds at a 16:1 reduction, you would have:

$$223 \text{ RPM} \times 16 = 3568 \text{ RPM at the motor}$$

For torque, you need 485 oz-in's. Suppose 90% efficient gearhead (10% losses):

$$(485/16) = 30 \text{ oz-in's of torque.}$$

Then increase by 10% to compensate for efficiency losses:

$$30 \times 1.1 = 33 \text{ oz-in at 3568 RPM would be required}$$

This would provide the maximum moment-of-inertia matching possible based on the above requirements.

Armed with this information, the customer can now look at the Moog Animatics motor torque curves to find the motor that fits.

For related information, see the topics in Mechanical Considerations on page 47.

Mechanical Considerations

This chapter discusses the mechanical considerations when a SmartMotor in the system design.

Torque Curves	48
Understanding Torque Curves	48
Peak Torque	48
Continuous Torque	48
Ambient Temperature Effects on Torque Curves and Motor Response	49
Supply Voltage Effects on Torque Curves and Motor Response	49
Example 1: Rotary Application	50
Example 2: Linear Application	50
Dyno Test Data vs. the Derated Torque Curve	50
Proper Sizing and Loading of the SmartMotor	51
Motor Sizing	53
Friction	53
Vertical Load	53
Acceleration	53
Inertia	53
Motor Shaft Loading	54
Axial Force	54
Radial Force	54
Moment of Inertia	54
Matching Motor to Load	54
Improving the Moment of Inertia Ratio	55
Gear Reduction Example	55
Application Sizing Equations	55
Calculating Power—The Real Story	55
Formula for Power to Torque:	56
Typical Friction Coefficients	56
Equation Symbol Definitions	57
Sizing Equations	58
Motor Mounting	59
Procedure	59
Cable Flex	62

Torque Curves

Understanding Torque Curves

Each set of torque curves depicts the limits of both continuous and peak torque for a given SmartMotor™ over the full range of speed.

Peak Torque

The peak torque curve is derived from dyno (dynamometer) testing. It is the point at which peak current limit hardware settings of the drive prevent further torque in an effort to protect the drive-stage components.

Continuous Torque

The continuous torque curve is also derived from dyno testing. It is the point at which the temperature rises from an ambient of 25°C to the designed thermal limit.

For example, the motor will be placed on the dyno tester and set to operate at 1000 RPM continuously with the load slowly increased until the controller reaches its maximum sustained thermal limit. This limit is either 70°C or 85°C depending on the model number. All Class 5 SmartMotor servos are set to 85°C.

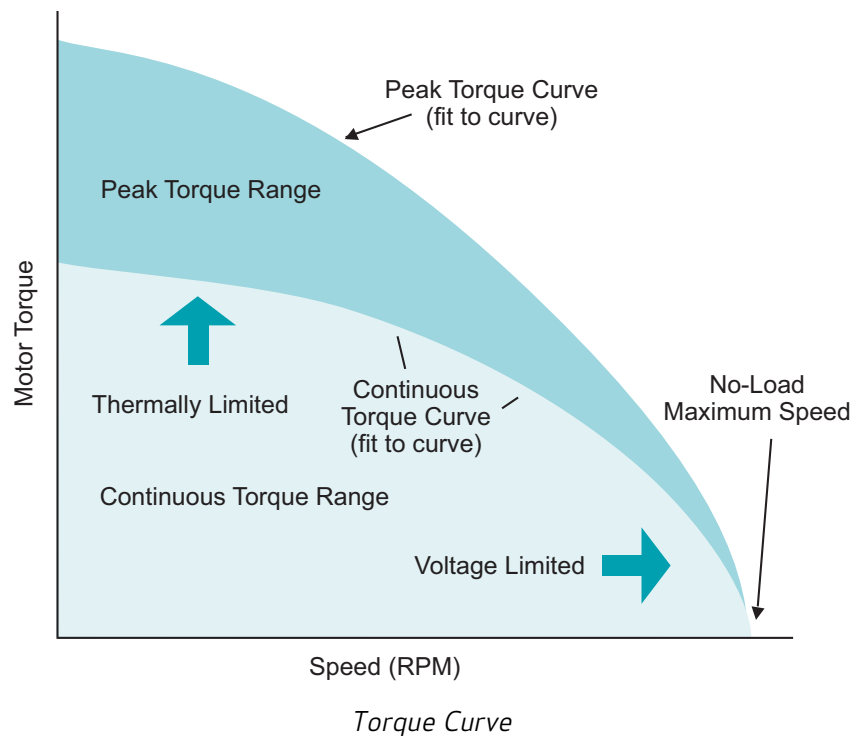

The lower-right side of the curve is limited by supply voltage. This is the point at which Back EMF suppresses any further speed increase. Higher supply voltages will shift the zero torque point of the curve further to the right.

Ambient Temperature Effects on Torque Curves and Motor Response

If the motor is operated in an environment warmer than 25°C, it will reach its thermal limit faster for a given load and further limit continuous torque. Therefore, any given motor torque curve *must be* linearly derated for a given ambient temperature from 25°C to 85°C for all Class 5 SmartMotor servos.

Supply Voltage Effects on Torque Curves and Motor Response

Higher voltages have a two-fold effect on torque curves. As mentioned previously, raising the voltage shifts the curve to the right; it also allows higher current into the drive. However, torque curves depict maximum allowable torque at a given velocity.

If you double the supply voltage, the motor can sustain twice the original velocity. Acceleration is also increased due to an increase in the peak torque curve. This may potentially be a significant reduction of time to complete moves due to the $a \cdot t^2$ term in kinematic equations. This is useful for high-speed indexing and fast start/stop motion.

NOTE: All torque curves shown in any Moog Animatics product catalog or the website also show the shaft output power curves.

Power can be calculated with the following equation:

$$\text{Power (W}^*) = \text{Torque (N.m)} \times \text{Speed (RPM)} / 9.5488$$

**In some versions of Moog Animatics literature, this was incorrectly shown as "kW".*

For any given mechanical system being moved by a SmartMotor, it is ideal to ensure the motor is running within its optimum performance range (see the following figure). Through proper mechanical system design, this can be achieved by adjusting one or more of the following items:

- Gear reduction
- Belt reduction
- Lead screw pitch
- Pinion gear diameter

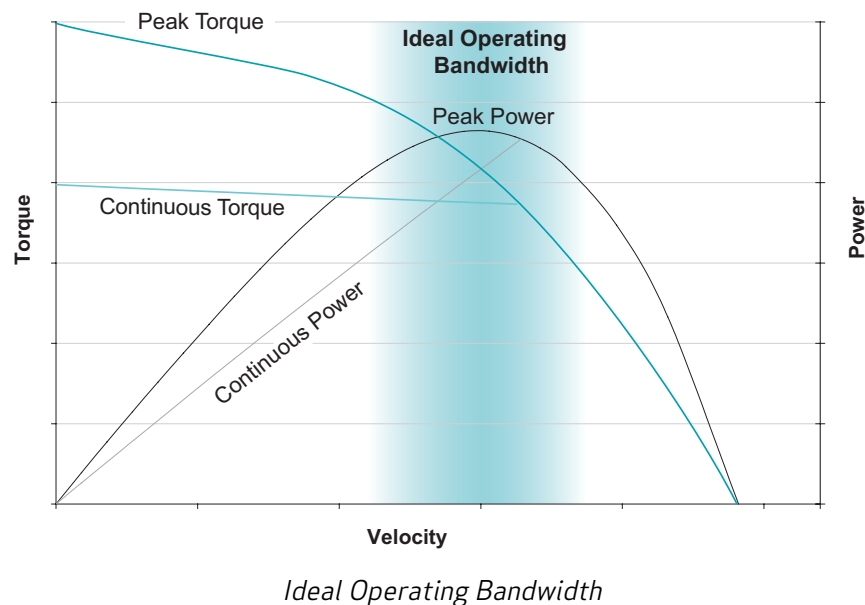

Example 1: Rotary Application

Suppose you have a load that requires 300 RPM at the output of a gear head, and the optimum speed range for the motor is 2100 RPM.

Divide the optimum operating speed by the load speed to get the ideal gear reduction. In this case: $2100 \text{ RPM} / 300 \text{ RPM} = 7$. So a 7:1 gear reduction would allow the motor to operate in its most efficient range.

Example 2: Linear Application

Suppose you need to run at 100 mm/sec using a ball screw, and the motor has an ideal range of 3000 RPM. $3000 \text{ RPM} / 60 = 50$ rotations per second (RPS). 100 mm/sec divided by 50 RPS is 2 mm per rotation. Therefore, an ideal pitch would be 2 mm.

Dyno Test Data vs. the Derated Torque Curve

NOTE: For any given product model number, there may be variations of as much as $\pm 10\%$.

The following diagram depicts data points collected from dyno testing of a given SmartMotor model. A best-fit torque curve is created from these data points and is then derated to at least 5% below the worst case data points. This means that within any given model number, every motor sold will perform at or higher than the advertised torque. Theoretically, all motors should be no less than 5% higher than advertised and may be more than 20% higher.

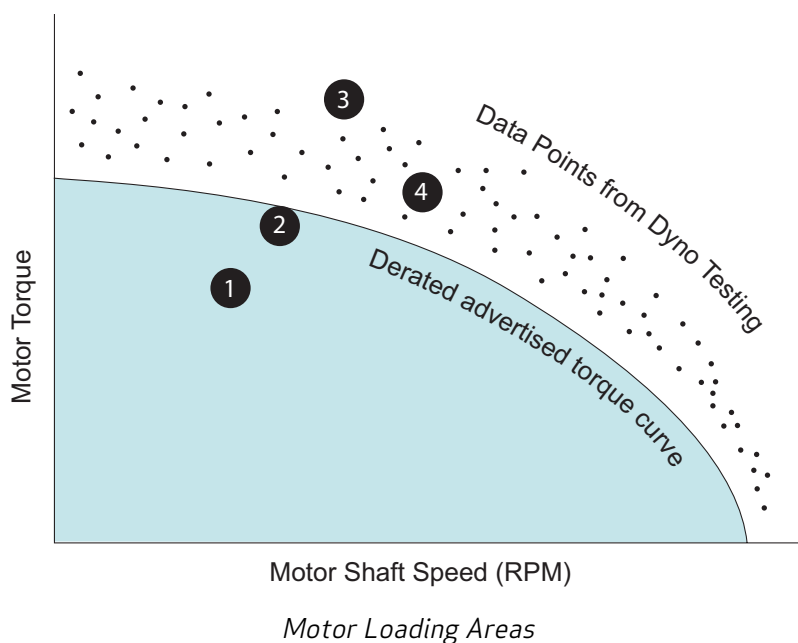

The diagram shows motor loading in four areas:

1. This is ideal and depicts a load within the normal operating range of the motor. The motor should operate well and have no problems for many years.
2. The load is very close to the operating limit. The motor will run quite warm as compared to Point 1.

3. The load exceeds the advertised level and exceeds +10% expected range of possible torque capabilities. In this case, the motor will most likely either overheat quickly and fault out or immediately generate a position error because it simply does not have enough power to support the load demand.



WARNING: Using an undersized motor can cause unpredictable machine performance and is a potential safety hazard (see Motor Sizing on page 9).

4. The load exceeds the advertised operating limit of the motor. However, due to data scatter and derating, there may be some motors that will work and others that do not. This is because it falls within the range of $\pm 10\%$ variation for motors for a given size. This can result in major problems for the machine builder.

For example, imagine designing a machine that operates in this range. Then you replicate that machine with many of them running on a production floor. One day, a motor at the lower end of the $\pm 10\%$ expected variation is placed on a new machine and that motor generates spurious drive faults. It appears as though the motor is malfunctioning because "all the other motors work just fine." This is unfortunate because, in reality, all motors were undersized in the machine design and are now operating outside of their advertised limits.

That is why it is important to properly calculate load torque to ensure the correct motor is designed into the application (refer to the next section). Never assume that testing of one motor means all motors of that size will work — it is simply not the case. You should never proceed without performing proper load calculation and motor sizing. The goal is to have all motors operating below the advertised limits, which will ensure reliable operation and long motor life.

Proper Sizing and Loading of the SmartMotor

It is important to properly calculate load torque to ensure the correct SmartMotor is selected and designed into the application. Consider the following sample figure. If properly sized/loaded, the motor can run at or under the Continuous Torque limit continuously, assuming 25°C ambient temperature. Further, the motor can tolerate intermittent operation above the Continuous Torque limit up to the Peak Torque limit for brief periods. However, that additional capacity may reduce as a function of time when operating above the Continuous Torque limit.

In order to protect the motor, Moog Animatics has designed in safeguards to limit current that may engage when the motor is operated for a sustained or accumulated brief periods above the continuous ratings (i.e., operating above capacity for torque/time). This could lead to position error or position error faults.

NOTE: These safeguards DO NOT indicate a defective motor. Rather, they are an indication that the motor may not be properly sized for the intended application, or that other design or environmental factors are affecting motor performance, such as unintended axial or radial forces acting on the load, elevated ambient air temperature, improper mounting that prevents adequate heat sinking, etc.

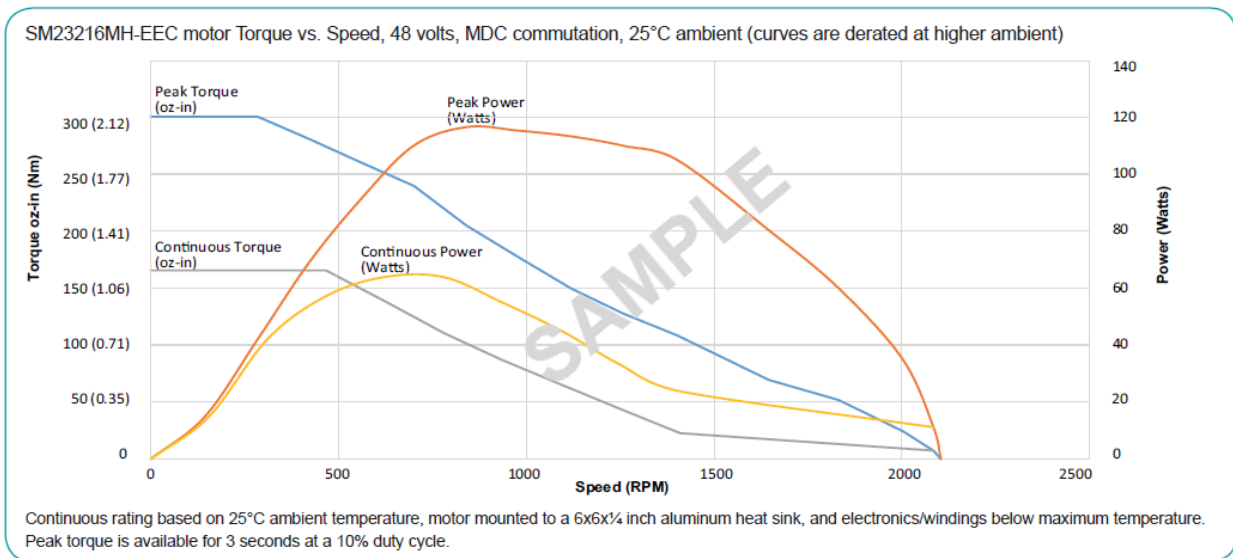

Sample Power Chart

To ensure that your SmartMotor successfully performs as intended:

- Select the proper power supply
- Use the proper electrical interface
- Properly size the motor for the intended application
- Consider the thermal environment
- Follow the proper mechanical and environmental implementation

Motor Sizing

This section discusses the considerations for properly sizing the SmartMotor to the application. There are four primary considerations:

- Friction
- Vertical Load
- Acceleration
- Inertia

Friction

Determine whether the motor selected has the torque to handle the friction.

A little friction in a SmartMotor's load can be quite good for added stability. A lot of friction will require that you consider the frictional load when sizing the motor. A 20% to 50% safety margin should be applied to an overall system, but where the frictional load is concerned, measurements should be taken to verify expected values under worst-case scenarios. The actual friction of a system should be measured over both temperature extremes that the machine is specified to operate within. A sampling of multiple units is also advisable to eliminate any anomalies.

Vertical Load

Determine whether the motor selected has the torque to support any vertical loading.

Calculating the torque applied to the motor due to a hanging load will produce a value that must be handled entirely by the motor's continuous torque capability, unless there is a brake in the system or some other device that would relieve the motor from the constant burden of this otherwise ever present load.

Employing a design with no vertical load component at all is ideal. Many applications don't carry this burden and those that do can be assisted with design elements such as spring mechanisms or counterbalances. Often, the most reliable solution is simply to use a SmartMotor with plenty of torque to support the constant load or to add a gearhead to a smaller motor.

Acceleration

Determine whether the motor selected has the torque to accelerate the load.

In most applications, the load's inertia is the greatest component of the motor's loading throughout the motion trajectory. Newton teaches us that $F=ma$ which tells us that it takes a force to accelerate a mass. Common motor sizing programs or simple equations such as this can be used to determine the torque required to accelerate a load.

Inertia

Determine whether the motor's rotor inertia is properly matched to the load.

Just because the motor selected can more than handle the friction and the acceleration of a load does not mean the job of selecting a motor is done. Extremely high inertial loads can prevent a servo from ever becoming stable. A rule of thumb is to be concerned when the load inertia, as felt from the shaft of the motor, is greater than 10 times that of the motor's rotor itself.

Under this circumstance, there are two saving factors:

- The first is friction. If there is sufficient friction to the system, then the stability can often be achieved, even with inertial mismatches as great as 100 to 1.
- The second saving factor lies in the demands of the motion. If it is not required that the load be started and stopped very rapidly, then the little stability actually required by the application may permit similarly high inertial mismatches.

Usually, actual experimentation is the only way to produce the answer.

Motor Shaft Loading

Ensure that the design places no appreciable axial or radial force on the motor's shaft.

Axial Force

Pressing in on the SmartMotor's shaft can cause damage to the rear bearing and possibly the encoder itself. The SmartMotor is designed to provide torque, not bearing support, to an application.

Radial Force

Radial force resulting from belt tension on a shaft-mounted pulley can also exert excessive forces on the motor's bearings. That said, the SmartMotor's front bearings are very sturdy. Therefore, the real concern with excessive radial force is bending of the shaft.

Moment of Inertia

A basic understanding of Moment of Inertia serves well in ensuring proper SmartMotor™ sizing. It is one thing to look at static points on torque curves, but it is altogether different when considering the dynamic aspects of loads being accelerated at high rates.

- The inertial mass of an object is a measure of its resistance to a change in its velocity.
- The Moment of Inertia of an object is at a point of reference of rotation, which is at the pivot point or axis of rotation.
- The Moment of Inertia can, therefore, be thought of as a measure of the resistance to any change in rotational speed.

For linear systems, the rate of change of speed (acceleration) is proportional to the force applied. Double the mass requires double the force to achieve the same acceleration. Similarly, for rotational systems, the angular acceleration of the load is proportional to the torque applied. Double the Moment of Inertia and the torque needs to be doubled for the same angular acceleration. Moment of Inertia is, therefore, a measure of a load's resistance to angular speed change, or how much effort (torque) is required to cause acceleration or deceleration.

Matching Motor to Load

A common rule of thumb for SmartMotor sizing is that the load should have no more than ten times the Moment of Inertia of the motor rotor that is driving it. This provides a good starting point and typically allows for safe sizing over a wide range of applications.

A rotating load wants to maintain the same velocity. Therefore, when a motor attempts to accelerate the load, it must overcome the Moment of Inertia of that load by applying additional torque to increase the speed. As a result, it takes more torque to change speed than it does to maintain a given speed.

In the same manner, for the motor to decelerate the load, the load's Moment of Inertia wants to keep the motor going the same speed and will, in effect, back-drive the motor, which turns it into a generator.



CAUTION: In extreme cases, back-drive can result in overvoltage damage to the motor's drive stage.

Improving the Moment of Inertia Ratio

Adding gear reduction to a motor gives it more leverage to prevent back-driving and also provides an advantage in accelerating a load up to speed.

Any given change in gear reduction results in a proportional change in speed and static torque, but results in a squared change in acceleration and dynamic rate of change of torque. The result is that by adding gear ratio you gain a squared decrease in the ratio of Moment of Inertia between motor and load.

Therefore, through gear reduction, the motor has a greater advantage in both accelerating and decelerating the load. Gear reduction adds protection against damage to the overall system.

Gear Reduction Example

For an actual example of the benefits of additional gear reduction, take a look at the following figure. This is an actual photo of the "before" and "after" drive system of a given application. The large motor with low gear reduction and large pulley was replaced by a much smaller Moog Animatics SmartMotor™ with much higher gear reduction and much smaller pulley. The result was a smoother operating machine with higher resolution and better acceleration, which increased throughout and improved quality. For additional information on gearheads, see Non-Captive Gearheads on page 44.

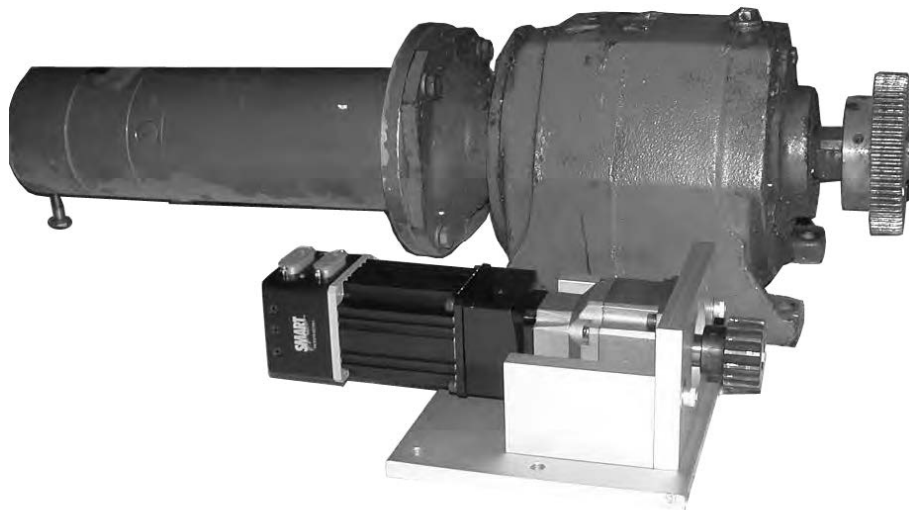

SmartMotor with Proper Gear Reduction vs. Inefficient Motor Design

Application Sizing Equations

Calculating Power—The Real Story

Unit of electrical power where: Watts =(volts)(amps) or $W=V \cdot A$ Watts are a unit consisting of time because amps are a measure of electron flow per unit time.

Formula for Power to Torque:

For this reason, Torque cannot be directly equated with Watts or Horsepower without consideration of RPM, where revolutions per minute contains time that would cancel out the time in watts to give you torque. That is why Horsepower is a useless unit of measure when sizing the SmartMotor™ for motion control applications!

NOTE: One horsepower equals 746 watts and has nothing to do with torque by itself!

Formula for Power to Torque:

$$\text{Power (HP)} = \text{Power (Watts)} \times 746$$

$$\text{Power (Watts)} = \frac{N \text{ (RPM)} \times T \text{ (ft-lbs)}}{7.04}$$

$$\text{Power (HP)} = \frac{N \text{ (RPM)} \times T \text{ (ft-lbs)}}{5252}$$

Torque required:

$$T \text{ (ft-lbs)} = \frac{\text{Power (Watts)} \times 7.04}{N \text{ (RPM)}}$$

$$T \text{ (ft-lbs)} = \frac{\text{Power (HP)} \times 5252}{N \text{ (RPM)}}$$

Typical Friction Coefficients

$$(F_x = \mu W_L \cos \gamma)$$

Materials	μ	Mechanism	μ
Steel on Steel	~0.58	Ball Bushings	<0.01
Steel on Steel (greased)	~0.15	Linear Bearings	<0.01
Aluminum on Steel	~0.45	Dove-Tail Slides	~0.2++
Copper on Steel	~0.30	Gib Ways	~0.5++
Brass on Steel	~0.35		
Plastic on Steel	~0.15-0.25		

Equation Symbol Definitions

The following symbols below are used in the formulas in Sizing Equations on page 58.

Symbol	Definition	SI	English
C_G	Circumference of Gear	m (or cm)	in (or ft)
$C_{P:1,2,3}$	Circumference of Pulleys, 1, 2, or 3	“	“
D_G	...(pitch dia.) of Gear	“	“
D_{PM}	...(pitch dia.) of Pulleys on Motor	“	“
$D_{P:1,2,3}$...(pitch dia.) of Pulleys 1, 2, or 3	“	“
e	efficiency of mechanism or reducer	%	%
F	Forces due to	N	lb
F_{Fr}	...friction ($F_{fr} = mWL \cos g$)	“	“
F_g	...gravity ($F_g = WL \sin g$)	“	“
F_p	...Push or Pull forces	“	“
g	gravity accel constant	9.80 m/s ²	386 in/s ²
J	mass moment of inertia for	kg-m ²	lb-in ²
J_C	...Coupling	g-cm ²	oz-in ²
J_G	...Gear	etc.	or
J_L	...Load	“	in-lb-s ²
$J_{L \rightarrow M}$...Load reflected to Motor	“	or
J_M	...Motor	“	in-oz-s ²
$J_{P:1,2,3}$...Pulley or sprocket 1, 2, or 3	“	“
J_{Total}	...Total of all inertias	“	“
J_S	...lead Screw	“	“
N_r	Number ratio of reducer	none	none
P_G	Pitch of Gear, sprocket or pulley	teeth/m	teeth/inch
P_S	Pitch of lead Screw	revs/m	revs/inch
T	Torque...(for “required” Calculations)	Nm	in-lb
T_L	...at Load (not yet reflected to motor)	“	“
T_p	...due to Preload on screw nut, etc.	“	“
V_L	linear Velocity of Load	m/s	in/s
ω_M	angular/rotational velocity of Motor	rad/s	rps or rpm
W_L	Weight of Load	kg	lb
W_B	Weight of Belt (or chain or cable)	“	“
W_T	Weight of Table (or rack & moving parts)	“	“
θ	rotation...	revs	revs
$\theta_{a,c,or d}$	rotation during accel, decel, etc.	“	“
θ_L	rotation of Load	“	“
θ_M	rotation of Motor	“	“
μ	coefficient of friction	none	none
γ	load angle from horizontal	degrees	degrees

Sizing Equations

Motion Mechanism and Motion Equations

Gearing

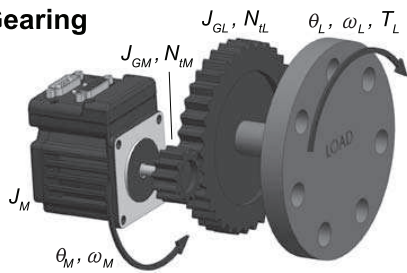

$$N_r = \frac{N_{IL}}{N_{IM}}$$

$$\theta_M = N_r \times \theta_L$$

$$\omega = N_r \times \omega_L$$

Inertia, Torque Equations

$$J_{Total} = J_M + J_{GM} + J_{GL-M} + J_{L-M}$$

$$J_{GL-M} = \left(\frac{1}{N_r}\right)^2 \times \frac{J_{GL}}{e} \quad J_{L-M} = \left(\frac{1}{N_r}\right)^2 \times \frac{J_L}{e}$$

$$T_{L-M} = \frac{T_L}{N_r \times e}$$

Rack & Pinion

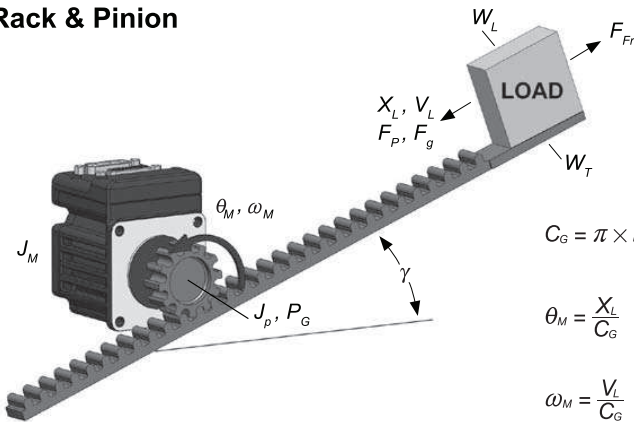

$$C_G = \pi \times D_G = \frac{N_t}{P_G}$$

$$\theta_M = \frac{X_L}{C_G}$$

$$\omega_M = \frac{V_L}{C_G}$$

$$J_{Total} = J_M + J_G + J_{L-M}$$

$$J_{L-M} = \frac{(W_L + W_T)}{g \times e} \times \left(\frac{D_G}{2}\right)^2$$

$$F_g = (W_L + W_T) \times \sin \gamma$$

$$F_{fr} = \mu \times (W_L + W_T) \times \cos \gamma$$

$$T_{L-M} = \left(\frac{F_p + F_g + F_{fr}}{e}\right) \times \left(\frac{D_G}{2}\right)$$

Belt Drive

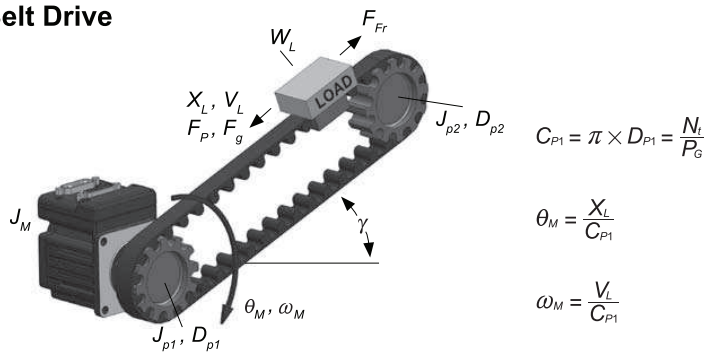

$$C_{P1} = \pi \times D_{P1} = \frac{N_t}{P_G}$$

$$\theta_M = \frac{X_L}{C_{P1}}$$

$$\omega_M = \frac{V_L}{C_{P1}}$$

$$J_{Total} = J_M + J_{P1} + \left(\frac{D_{P1}}{D_{P2}}\right)^2 J_{P2} + J_{Load}$$

$$J_{L-M} = \frac{(W_L + W_B)}{g \times e} \times \left(\frac{D_{P1}}{2}\right)^2$$

$$F_g = (W_L + W_B) \times \sin \gamma \quad F_{fr} = \mu \times (W_L + W_T) \times \cos \gamma$$

$$T_{L-M} = \left(\frac{F_p + F_g + F_{fr}}{e}\right) + \left(\frac{D_{P1}}{2}\right)$$

Leadscrew

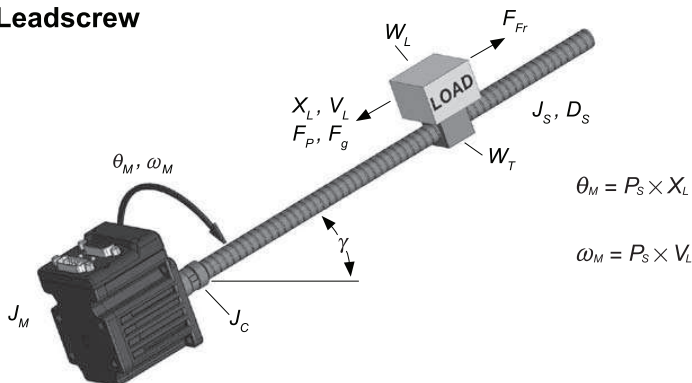

$$\theta_M = P_S \times X_L$$

$$\omega_M = P_S \times V_L$$

$$J_{Total} = J_M + J_C + J_S + J_{L-M}$$

$$J_{L-M} = \frac{(W_L + W_T)}{g \times e} \times \left(\frac{1}{2\pi \times P_S}\right)^2$$

$$F_g = (W_L + W_T) \times \sin \gamma \quad F_{fr} = \mu \times (W_L + W_T) \times \cos \gamma$$

$$T_{L-M} = \left(\frac{F_p + F_g + F_{fr}}{2\pi \times P_S \times e}\right) + T_P$$

Motor Mounting

This section describes the general steps for mounting a SmartMotor to a mounting plate or other machined surface.

NOTE: For instructions on mounting a SmartMotor to a gearhead, see Non-Captive Gearheads on page 44.

The following figure shows two views: an exploded view and an assembled view.

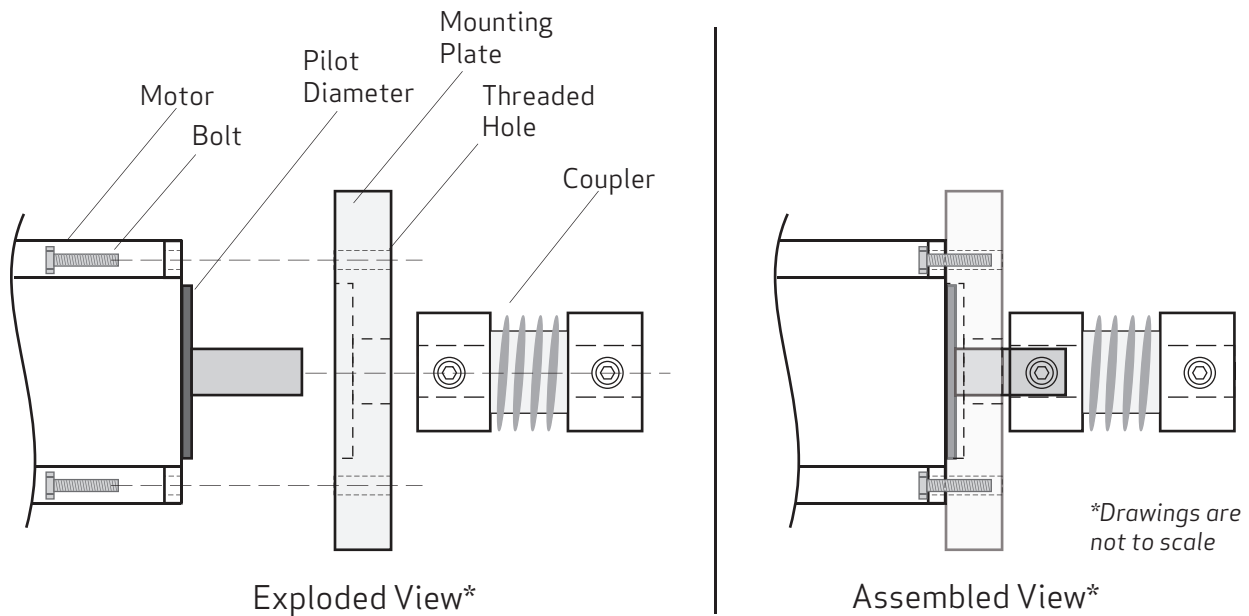

Views of the Motor Mounting

In addition to the parts shown, you will need nuts if you are using non-threaded holes in the mounting plate. The use of washers, lock washers and/or liquid thread locker may also be required. These items are application specific. If guidance is needed, please contact Moog Animatics for assistance.

Procedure



CAUTION: Only use servo rated couplings that allow for some radial and axial misalignment. Do not use rigid or solid couplings.

Refer to the previous figure while performing the following steps.

1. Visually inspect both the face of the motor and the mating surface of the mounting plate to make sure they are clean (i.e., free of dust, debris, grease, oil or other contaminants).
2. Carefully align the pilot diameter of the motor with the machined area of the mounting plate.
3. Slowly insert the motor making sure the motor shaft is aligned and inserted into the coupler (if present) or other drive connection mechanism.

4. Once the motor face is against the mating surface of the mounting plate, rotate the motor body to align the bolt holes with the corresponding holes in the mounting plate.
5. Insert 1 bolt into each bolt hole and finger tighten only.
6. Tighten the bolts in an X pattern to ensure even pressure is applied across the mating surface. Refer to the following figure.

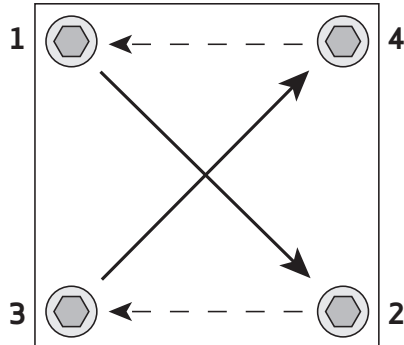

X-Pattern for Bolt Tightening

For example, tighten the top left bolt until hand tight, then the bottom right bolt, then top right bolt, then bottom left bolt.

NOTE: The use of X-pattern tightening is especially important when mounting a motor to a surface that has a seal. It helps ensure that the seal is not damaged or pinched.

7. Repeat the X pattern until all 4 bolts are properly torqued. For recommended torque, refer to the following table.

Screw size (alloy steel)	Recommended torque (in-lbs)	Tolerance +/- (in-lbs)
4	15	3
6	25	5
8	45	10
10	66	13
1/4	115	15
5/16	175	20
3/8	250	25

8. If a coupler is present, adjust the coupler so that it contains the ends of both shafts to be coupled together. Tighten the set screws on the coupler.

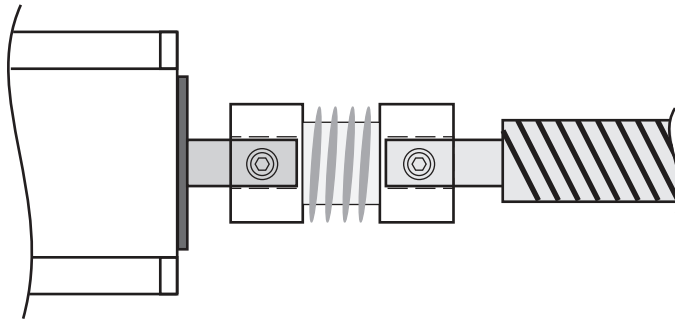

Coupler Joining Two Shafts

Cable Flex

Cable flex is an important point that must be considered in the system design.

Moog Animatics cables are manufactured to the same specification as high-flex cables (or continuous flex), which feature a spiral wrapped shield and inner lubricating film layer. Note that "high flex" and "high twist" are two very different types of cables. High-twist cables require large-jacketed, coiled inner cables with a large air gap.

The minimum bend radius is the tightest radius a cable should be moved through under a flexing application. Proper use of cable carriers should adhere to this minimum bending radius. Exceeding the minimum bending radius of any given cable will cause breakdown in the insulation and inner conductors, which could lead to shorts and/or loss of shield integrity. Please consult the engineering drawings for the cables and note the minimum bending radius.

At any time high flex is expected, special care should be taken at the cable terminating ends near the connectors. Flex in the cable should not be transmitted toward the connector, as it may cause failures inside of the connectors. A best practice would be to firmly tie off the cables near the connector to prevent any flex from reaching the connector end of the cable.

NOTE: Allowing flex directly at cable terminations could cause conductors to break loose from the termination.

Finally, note that repeated high flex over time will shorten the life of any cable regardless of its flex rating. Therefore, it is always best to minimize any flexing of cables to preserve their life and increase the reliability of the system.

Environmental Considerations

This chapter provides recommendations for environmental conditions, such as thermal (ambient temperature), humidity, IP sealing, and more.

Thermal	64
Temperature Considerations	64
Heat Sinking	64
Humidity	65
IP Sealing	65
Clean Room	67
Clean Air Purge and Vacuum	67
Clean Room Classifications	67
High Altitude	67
Vacuum	68

Thermal

This section discusses thermal environmental conditions that should be considered in the system design.

Temperature Considerations

The SmartMotor is rated to perform efficiently at the standard room temperature of 25°C.

- If the ambient temperature goes above that threshold, the full continuous torque rating of the motor should not be expected.
- If, however, the ambient temperature is below the threshold, then more than the rated torque is available from the motor. (In other words, a colder motor = higher torque, and a hotter motor = lower torque.)

The following table shows the variance of available continuous torque output as a function of temperatures.

NOTE: Avoid applications above 70°C ambient temperature.

Temperature Variance Chart	
Temperature (°C)	Continuous Torque (% rated torque)
0	133%
5	133%
10	133%
15	126%
20	112%
25	100%
30	89%
35	79%
40	71%
45	63%
50	56%
55	50%
60	45%
65	40%

Heat Sinking

In most applications, it is desirable to maximize heat sinking of the motor to keep it operating at or below the target temperature, which will provide the desired level of continuous torque (see the previous table). The following are items to consider for heat sinking the motor:

- Thick aluminum bulkheads are ideal heat sinks.
- If more heat sinking is available, then more continuous torque can be generated by the motor and higher ambient temperatures can be better tolerated.
- Motors are rated on a 10" x 10" x 1/4" (L, W, H) heat sink. It is recommended to use the motor mount's heat sinking capabilities to maximize heat dissipation, better tolerate higher ambient temperatures and thus help generate more continuous torque output.

For more information, watch the following video on our YouTube channel:

Motor Thermal Limit Fault - Carpet Positioning Application

https://www.youtube.com/watch?v=Jfc8q6_1qQs

Humidity

Some amount of humidity is needed for comfort and proper electrostatic discharge (ESD) control. However, an overly humid environment, which is above dew point and forming condensation, will cause improper operation of the SmartMotor and other sensitive equipment.

The SmartMotor uses an optical encoder to track its position. Therefore, when dew point is reached, the optics will be at risk of improper reading of the encoder disk. As a result, positional accuracy will be lost, which will cause feedback errors.

When using unsealed SmartMotors, the following are considerations regarding humidity in the operating environment.

- Do not expose the motor to fluids or excessive moisture
- Ensure the relative humidity is <85% and non-condensing
- All current unsealed Moog Animatics products are rated for a non-condensing atmosphere, which means that the dew point should not be reached.

NOTE: Dew point is the point at which moisture will begin to condense onto the surface causing droplets to form.

Additional concerns:

- If the environment exceeds dew point, then it is highly recommended to use IP sealed motors. For more information, see IP Sealing on page 65.
- If the condensing humidity also contains other substances such as salts, this could cause shorting of electrical paths and corrosion of metal surfaces.

For more information, watch the following video on our YouTube channel:

Environmental Considerations for Motion Control Applications: Condensation

<https://www.youtube.com/watch?v=HXyJpmvU8FE>

IP Sealing

The use of IP sealed motors is important for high humidity and washdown environments. The following information is an excerpt from the Moog Animatics white paper "*Integrated Solutions for Harsh Environments*".











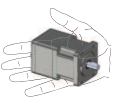

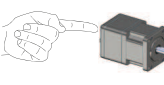
The correct IP specifications must be paired with the specific high humidity or washdown environment. Incorrect specifications could result in production downtime and high equipment replacement costs. From cabling to motors to the control cabinet, high humidity or washdown environments demand attention to detail in the machine building process.

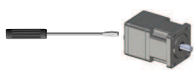
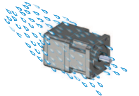
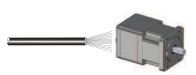
For motion control system selection purposes, one of the best references for high humidity or washdown environments is the IP rating system (or IP code).

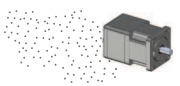
"IP" stands for "Ingress Protection," and is defined in international standard IEC 60529, which classifies and rates the degrees of protection for metal castings and electrical enclosures against solid objects, dust and water.

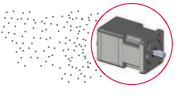
The IP code consists of the letters IP followed by two digits, or one digit and one or two letters. The IP code helps to give concrete specifications to vague terms such as "waterproof".

- The first number indicates protection against solid particles.
- The second number indicates protection against ingress of liquid.
- The larger the digit, the greater the protection offered.
- The IP rating system is only used for water and non-caustic liquids.

IP TABLE REFERENCE			
FIRST DIGITAL: Ingress of solid objects	Sample	SECOND DIGIT: Ingress of liquids	Sample
0	No protection	0	No protection
1	Protected against solid objects over 50mm (e.g. hands, large tools). 	1	Protected against vertically falling drops of water or condensation. 
2	Protected against solid objects over 12.5mm (e.g. hands, large tools). 	2	Protected against falling drops of water at up to a 15° angle from normal orientation. 
3	Protected against solid objects over 2.5mm (e.g. wire, small tools). 	3	Protected against water spray from any direction at up to a 60° angle from normal orientation. 
4	Protected against solid objects over 1.0mm (e.g. wires). 	4	Protected against water splash from any direction. 
5	Limited protection against dust ingress (no harmful deposit). 	5	Protected against low-pressure water jets from any direction. Limited ingress permitted. 
6	Totally protected against dust ingress. 	6	Protected against high-pressure water jets from any direction. Limited ingress permitted. 
Example: SM23165M-IP65 (NEMA 23) The two digits represent different forms of environmental influence: • The first digit represents protection against ingress of solid objects. • The second digit represents protection against ingress of liquids.		7	Protected against short periods of immersion in water 1m deep for up to 30 minutes. 
<div style="display: flex; justify-content: space-around; align-items: center;"> <div style="background-color: #800000; color: white; padding: 10px; border-radius: 5px; width: 40px; text-align: center;">6</div> <div style="background-color: #008080; color: white; padding: 10px; border-radius: 5px; width: 40px; text-align: center;">5</div> </div>		8	Protected against long periods of immersion in water. Motors are hermetically sealed. 

NOTE: Moog Animatics does not currently support any products rated above IP67.

For more details, refer to the Moog Animatics white paper "*Integrated Solutions for Harsh Environments*", which is available from the Moog Animatics website at: <http://www.animatics.com>.

Clean Room

Moog Animatics SmartMotors have been used extensively in Class 100 (ISO 5) clean rooms for many years and are fully certified for that application. There are also some installations into Class 10, although the motors have not been officially certified for use in Class 10 (ISO 4) environments.

Clean Air Purge and Vacuum

It is possible to place clean air purge onto motors or actuators. However, this is NOT for making the product clean room compatible; rather, it is to prevent contamination from entering the product.

This should not be confused with vacuum purge, where the product is, in fact, being purged with negative pressure to prevent outgassing or shedding of particles from within. Vacuum being applied may be an option where there are concerns of clean room contamination. Remember, this means applying a negative pressure differential across the body of the product housing. This does not imply that the motor may operate in a vacuum, as heat cannot dissipate through a vacuum. That is another environmental consideration, and is discussed in Vacuum on page 68.

Clean Room Classifications

There are two standards for clean room classifications: FS 209E and ISO 14644-1. The ISO guidelines are the most current and in use today, although many previously installed clean rooms were originally fabricated to the FS 209E guidelines.

The standards classify the clean rooms according to the number and size of particulates allowed. Specialized instruments are used to take measurements of the particulates in the room at various predetermined locations.

For more details, refer to the full specifications available from the International Organization for Standardization (ISO) at www.iso.org.

High Altitude

This topic describes considerations for using the SmartMotor in high-altitude applications (above 5K feet).

There are two factors to consider when operating at high altitudes:

1. The air gets thinner as altitude increases; therefore, heat transfer becomes less efficient.
2. Electrolytic capacitor performance degrades as altitude increases.

Note that SmartMotors are operating in the 5-6K foot altitude range, like Denver Colorado, and applications at that altitude have not exhibited any problems.

For more information on high-altitude applications, watch this video on our YouTube channel:

High Altitude Application Considerations for Motion Control

<https://www.youtube.com/watch?v=xxKJC1-Vw3k>

Vacuum

This topic discusses considerations for using the SmartMotor in a vacuum.



CAUTION: SmartMotor products are not vacuum rated!

The primary consideration for operating in a vacuum environment is that there is no way to dissipate heat from a motor. In a normal (non-vacuum) environment, heat generated by the motor is transferred through the motor case and base coupling to the air circulating around the motor/mechanism. For this reason, the SmartMotor products are not rated for operation in a vacuum environment.

Therefore, operation in a vacuum environment would require:

- Some type of physical coupling to the outside (outside the vacuum), or
- Insertion of cooling mechanism into the vacuum (e.g., hoses blowing cold air) so that heat could be dissipated.

For more information, refer to Thermal on page 64. Also, watch the following video on our YouTube channel:

Motion Control in a Vacuum and Heat Dissipation

<https://www.youtube.com/watch?v=rAolGBrqHOk>

FAQs

This topic contains frequently asked questions (FAQs) pertaining to material discussed in this document.

Downloading and Uploading Programs

Why will SMI version 2 and later not let me download to a SmartMotor™ that is moving or running a program?

Due to safety concerns, the SMI version 2 and later software forces you to turn off the SmartMotor™ holding current, or stop a running program before download, to prevent possible unexpected motion. Let's suppose you have a program that places the SmartMotor™ in Velocity mode or Torque Mode and then you try to download without first tuning off the motor. During travel, it will crash into the end stop while downloading. For safe operation we want to ensure the SmartMotor is in the OFF condition.

When I start a download, the motor stops everything it was doing. Why?

When SMI starts a download of a new program, it issues the END command to stop prior code from running. This is to prevent processor memory pointer errors while the EEPROM header portion is being re-written. It is also for safety reasons.

Is there a way to prevent someone from uploading a program?

Yes. You can protect your program from being seen or copied by sending LOCKP to the motor via serial port. The LOCKP command is a means of locking the program. It does not prevent a user from downloading a new program, but it does prevent them from seeing the program you have downloaded.

I/O Handling

Since the I/O is non-isolated 5 VTTL, are there any options for 24 VDC I/O?

Yes, there are a few options. Moog Animatics provides cables with built in 5 V to 24 V isolated logic circuits right in the connector hood. This allows the user to have a choice of either 4 Inputs and 3 Outputs or 5 Inputs and 2 Outputs at 24 VDC. They can be set as sinking or sourcing. The CBLIO-IS01 series cable can be purchased in lengths from 3 to 10 meters. The DINIO7 is a DIN rail mount breakout board that also provides a means of isolation using Industry Standard Opto-22, Gordos, or Grayhill I/O modules such as ODC, IDC, OAC and IAC series. The DINIO7 also allows interconnection to other motors and their I/O via a built-in back plane.

Are there any Expanded I/O options?

Yes. Each Class 5 SmartMotor has the AD1 option providing an additional 10 channels of isolated 24V sourcing I/O. This option will appear as an additional 12 pin 12 mm connector where 24 VDC must be supplied to make it work. Each channel may be configured as Sourcing Input, Sourcing Output, or 10 bit analog input. As analog inputs, they may be read over the range of 0-5VDC or zero to full supply rail. The Analog reading returns either raw binary value or millivolts directly.

All I/O pins are reverse voltage, over current, and short circuit protected. A fault on an I/O pin requires a down power reset.

What type of electrical protection/isolation does each I/O pin have?

Each I/O pin has a 100 Ohm series current-limit resistor tied to a 5.6 VDC over-voltage limiting Zener diode. The user ties into the 100 Ohm resistor directly. The connection between the 100 Ohm resistor and Zener diode ties in directly to the CPU pin. This is why the motors are limited to 5V TTL I/O logic levels only. Moog Animatics does, however, provide 24 VDC I/O adapters and adapter cables for

converting the 5 VDC I/O to optically isolated 24 VDC logic for connection to PLCs and other equipment. Please visit the Moog Animatics website and search under Cables and Accessories.

Power Supplies

Which is better, Linear or Switcher Supplies?

Linear supplies are better suited for inductive loads. SmartMotor™ servos are inductive loads. Linear supplies can handle high current surges typically caused by starting and stopping of servo motors. However, linear supplies have what is known as voltage droop. This is characteristic of voltage dropping down with an increase in load. Typically, unregulated toroidal transformer supplies will drop 4 to 7% and E-Core types (the big square transformers) are >10%. Switchers have no voltage droop until they reach maximum load. Then they just drop completely to zero volts. However, since they maintain a tight control over voltage up to the trip point, they can typically aid greatly in reaching maximum speed and acceleration of a given servo. However, the switching supply must be sized for the maximum expected peak current draw of the motor system. A linear supply only needs to be sized for continuous load. Linear supplies have a large capacitance to supply much higher current surges when needed, so this is more of an application specific question.

What concerns are there with maximizing voltage on the supply?

The higher the voltage, the faster the SmartMotor can move and the faster it can accelerate. This is a good thing. However, in conjunction with this, the higher the voltage, the closer you get to a peak voltage that can cause over-voltage breakdown of the controller. Also, the higher the voltage, the faster a rate of change of current can occur. It is a risk with any application to get faster response by moving towards a higher voltage. Typically speaking, it is the dynamics of sudden changes that increases risk by an "x²" factor whereas the continuous load risk is only a direct ratio increase. This is because rate-of-change in current is proportional to acceleration which is the square of velocity, i.e., x². For safety sake, a 42 VDC supply for a 48 VDC system gives good margin with little speed losses.

How do I size Power Supplies?

The quick answer is "more is better". First, be sure you have the correct SmartMotor for the job. After that has been done, take the nominal power rating for that motor and you should size a LINEAR supply to provide about 10% more power to allow for longer sustained current loads. Any linear supply will typically provide more than enough peak current. This is where sizing gets tricky with Switch-Mode Power supplies. "SWITCHERS" typically come with some rated voltage and current.

For example, consider 48 VDC at 6 Amps. Well, that is just it...switch-mode supplies can provide 48 VDC "nailed to the wall" all the way up to 6 Amps, but if any more current is applied, the power supply will drop out to zero VDC and typically reset. Refer to the figure Linear Versus Switcher Voltage Drop Comparison on page 33. Any time you wish to use switchers, you need to take the peak expected load of the motor and size the switcher's continuous rating for that contingency.

As a rule of thumb, any NEMA 23 Frame SmartMotor™ can pull as much as 12 Amps instantaneous. Most 23 frame SmartMotor servos will not pull more than about 9 Amps instantaneous. A 10 Amp switcher can supply any 23 frame SmartMotor for MOST applications. With a 34 frame SmartMotor will require a 20 Amp continuous rating to be sure you will not get a tripped power supply. 34 frame SmartMotor can pull as much as 40 Amps or more for a few milliseconds, so as originally stated: "bigger is better," especially when it comes to switchers.

Back EMF

How do I protect against Back EMF?

Short Answer: Don't back-drive the SmartMotor.

The problem is that back-driving the SmartMotor isn't the only means to produce Back EMF. For information on the sources of back EMF, refer to Shunts on page 40.

The best way to protect against Back EMF is to use a shunt such as the active 48 VDC 100 Watt shunt supplied by Moog Animatics. It drops a 100 Watt load onto the bus any time bus voltage exceeds 49.5 VDC. It removes the load when bus voltage goes back down below 46 VDC. It will work with switching or linear supplies as long as no-load voltage does not stay above 48 VDC. Otherwise the shunt will be on all the time.

Another method of protection is to use a mechanical brake controlled by the brake commands in the motor. The SmartMotor can respond to a fault and send a signal to the brake within 250 μ sec to help hold the shaft from back driving. Note that none of the above ideas help against hitting a hard stop. Please read the next FAQ for more.

What is Back EMF and where does it come from?

For information on the sources of back EMF, refer to Shunts on page 40.

How do I prevent a hard-stop crash?

The best recommendation for preventing damage to the SmartMotor/controller in the case of hitting a hard stop is to place a limit switch near the hard stop that trips the motor off line just prior to hitting the stop. The best way to prevent it beyond that is to prevent the cause of hitting the hard stop in the first place.

If this is due to jogging the SmartMotor in Velocity Mode and not releasing the jog switch in time, then jog in Position Mode instead and use the "X" or "S" command to stop the SmartMotor when the jog switch is released. In any case, much care should be taken to be sure the SmartMotor is not intentionally or unintentionally allowed to hit a hard stop while under normal speeds and load conditions.

Communications

I have a SmartMotor that will not communicate no matter what I try. What should I do?

It is possible to unintentionally write and download a program that will lock up the CPU or prevent serial communications. If you power it up and there is one or more LEDs lit, then try the following:

1. Isolate the SmartMotor such that you have a single motor power and communications cable between the SmartMotor and the PC.
2. Connect the motor to the PC serial port, but DO NOT power up the SmartMotor. In other words, have the power supply either disconnected or turned off.
3. Then start up the SMI software and click on the TOOLS drop-down menu.
4. Under TOOLS, click on "Communications Lock-up Recovery" and a pop-up window will tell you to do what is described above.
5. Then click NEXT. The Lock-up Recovery utility will begin transmitting multiple "E" characters to the motor. It will tell you to power-up the SmartMotor at this point. Then it will wait about one second and attempt to establish communications. If it does establish communications, it will tell you and then prompt you to either clear the program or upload a new program.

At this point, it is advisable to clear the EEPROM to down-power reset the motor and reestablish communications normally. This way you will know if it was just a program issue or a hardware issue. If you apply power and there are no LEDs lit up on the motor, then there is a major problem with it electrically. It will have to be sent back for repair.

Occasionally, I lose communications and don't know why. What could be causing this?

Here are some general things to consider:

- Shielding and grounding must be done properly to ensure good signal integrity.
- Long character strings should be avoided. The receive buffer is only 16 bytes long.
- Never use the shield as the ground reference connection for RS-232 or RS-485.
- Make sure there are no non-terminating strings being transmitted. If a string is not followed by a carriage return or space character, the SmartMotor will hang indefinitely while waiting on the terminating character. It is done this way to allow priority to the serial ports over any downloaded program execution.

How far can I transmit on RS-232 or RS-485?

"RS" in the RS-232 and RS-485 specification means "Recommended Standard." Not every company or chip manufacturer actually meets the "RS." The IEEE specification states that RS-232 single-ended signal is SUPPOSED to be +/-12 VDC or a 24 VDC swing from logic zero to logic 1. The specification for RS-485 is +/-5 VDC differential. By voltage levels, RS-232 will logically be able to transmit much further. By noise immunity, a differential signal should be able to reach its destination "cleaner". The reality is similar to the following analogy: a clean whisper can't be heard a mile away, but a loud guttural voice can. RS-232 can transmit further but RS-485 transmits cleaner.

Also, note that the higher the voltage level, the higher the induced noise must be to overcome the signal, so RS-232 isn't so bad after all. As far as actual distance goes, there are applications in the field running 250 feet on RS-232. RS-485 can't drive the cables well enough to go beyond 100 feet without experiencing loading problems. Also, RS-485 is a parallel bus. The more motors you add, the shorter the overall practical distance due to bus loading. RS-232 is serial. Therefore, one motor transmits directly to only one "receive" buffer. This means compounded bus loading does not occur—another reason RS-232 can actually transmit further.

I'm using PROFIBUS between multiple SmartMotors and the communication sometimes drops out or does not initialize in the first place. What might be the cause?

First, check your baud rate and cable lengths between nodes. To use baud rates at or above 1.5 Mbps, special connectors ARE required. These connectors must have built in inductors in order to run these higher rates over PROFIBUS. Additionally, the minimum cable length between two nodes MUST BE 1M (3 feet). If the cable is too short, reflected impedance can cause loss of communications data packets and spurious node errors. Branch lines are not permitted when using baud rates greater than 1.5 Mbps. For more about PROFIBUS and the SmartMotor, see PROFIBUS Communications on page 25.

Success Checklist

Use this checklist to ensure success with the Moog Animatics SmartMotor™ and to maximize your system's reliability. Please take a minute to see that your system design and implementation pass these checks. Keep this page handy to document your settings and send it along with any motors returned for inspection or repair.

1. Select the proper power supply.

- Keep the SmartMotor's voltage below 48 VDC by...
 - operating at 42 VDC or less as nominal, or
 - using a shunt near the motor, or
 - adding a shunt to a switching power supply, or
 - operating at 42 VDC or less and adding a shunt for a vertical application.

NOTE: Drive Power and Control Power are separate inputs. Control power is rated to a range of 18 to 32 VDC max; drive power is from 18 to 48 VDC max. For motor-specific specs, consult your SmartMotor datasheet.

2. Use proper electrical interfacing.

- Avoid creating any ground loops with the communications by...
 - isolating the ground prong of the host PC for a single motor application, or
 - isolating the motor's power supply for a single motor application, or
 - using a communication isolation product to protect each axis

This does not apply when no serial communications are employed.

- Avoid creating any ground loops with the SmartMotor's I/O by...
 - using the main or 5V power at the motor to operate any sensors, or
 - using an optocoupler to interface to the inputs or outputs, or
 - using an I/O isolation product

3. Size the SmartMotor™ for the application.

- Determine that the motor selected has the torque to handle the friction.
- Determine that the motor selected has the torque to support any vertical component of the load.
- Determine that the motor selected has the torque to accelerate the load.
- Determine that the motor's rotor inertia is properly matched to the load.

4. Consider the thermal environment.

- Consider the ambient temperature and avoid applications above 70° C ambient. For ambient temperature above 25° C, Continuous Torque must be linearly derated to 0% at 85° C.
- Maximize the heat sink capability of the motor mounting surface.

5. Consider shaft loading, fluids and humidity.

- Ensure motor shaft loading is within axial and radial limits.
- Ensure that the motor does not get exposed to fluids or excessive moisture.
- Ensure relative humidity is <85% and noncondensing.



Noise filtering may be necessary—ports 0, 1, 2, 3 and 6 are high-speed inputs.

1. Ports 0 and 1: Ports 0 and 1 may be configured as Phase A and B encoder input or Step and Direction input. To ensure proper operation when following external encoders, it is strongly advised to use Line Driver encoders or encoders with true push-pull drive capability. This allows up to 1.5 MHz input frequency. Open collector output encoders will not work above 20 kHz or so, typically due the inability to drive input capacitance well enough.

2. Ports 2 and 3: Both Ports 2 and 3 default as Overtravel Limit inputs. They can be triggered by a negative edge transition as fast as 5 microseconds allowing optimum fail-safe detection of overtravel. However, as a result, in noisy systems, it may require capacitive filtering to prevent false triggers from static or other induced noise.

3. Port 6: Port 6 defaults as the “sync” or synchronous trigger input. This means any time it goes low, the processor issues a “G” command. The purpose of this is to allow precondition setup of motion profiles and then, via hardware input, the user may synchronize multiple motor/axis starts at the exact same time. However, similar to the Over Travel limit inputs, Port 6 can detect input pulses down to 5 microseconds. To ensure no false triggers, some system installs may require capacitive filtering to avoid false triggers.

In all cases above, typical filtering is through 10 to 100 pF ceramic capacitors tied from the input pin to ground. This is only a recommendation; system characteristic may vary depending on surrounding equipment.

Glossary

The following list provides a glossary of industrial motion terms.

Acceleration

A change in velocity as a function of time. Acceleration usually refers to increasing velocity, and deceleration to decreasing velocity.

Accuracy

A measure of the difference between expected position and actual position of a motor or mechanical system. Motor accuracy is usually specified as an angle representing the maximum deviation from expected position.

Address

A unique identifier assigned to a network device that differentiates it from other devices operating on the same network.

Ambient Temperature

The temperature of the cooling medium, usually air, immediately surrounding the motor or another device.

Angular Accuracy

The measure of shaft positioning accuracy on a servo or stepping motor.

Back EMF (BEMF)

The voltage generated when a permanent magnet motor is rotated. This voltage is proportional to motor speed and is present regardless of whether the motor winding(s) are energized or unenergized.

Breakaway Torque

The torque required to start a machine in motion. Almost always greater than the running torque.

Brushless Motor

Class of motors that operate using electronic commutation of phase currents rather than electromechanical (brush-type) commutation. Brushless motors typically have a permanent magnet rotor and a wound stator.

Closed Loop

A broadly-applied term relating to any system in which the output is measured and compared to the input. The output is then adjusted to reach the desired condition. In motion control, the term typically describes a system utilizing a velocity and/or position transducer to generate correction signals in relation to desired parameters.

Cogging (Cogging Torque)

A term used to describe nonuniform angular velocity. Cogging appears as jerkiness, especially at low speeds.

Commutation

A term which refers to the action of steering currents or voltages to the proper motor phases so as to produce optimum motor torque. Proper commutation means the relationship of the Rotor to the Stator must be known at all times.

- In brush-type motors, commutation is done electromechanically through the brushes and commutator.
- In brushless motors, commutation is done by the switching electronics using rotor position information obtained by Hall sensors, single turn absolute encoder or a resolver.

Controller

A term describing a functional block containing an amplifier, power supplies and possibly position-control electronics for operating a servomotor or step motor.

Current at Peak Torque (IPK) (Amperes)

The amount of input current required to develop peak torque. This is often outside the linear torque/current relationship.

Current, Rated

The maximum allowable continuous current a motor can handle without exceeding motor temperature limits.

Detent Torque

The maximum torque that can be applied to an unenergized step motor without causing continuous rotating motion.

Duty Cycle

For a repetitive cycle, the ratio of on time to total cycle time.

$$\text{Duty cycle (\%)} = [\text{On time} / (\text{On time} + \text{Off time})] \times 100\%$$

Dynamic Braking

A passive technique for stopping a permanent magnet brush or brushless motor. The motor windings are shorted together through a resistor which results in motor braking with an exponential decrease in speed.

Efficiency

The ratio of power output to power input.

Electrical Time Constant (te) (Seconds)

The time required for current to reach 63.2% of its final value for a fixed voltage level. It can be calculated from the relationship

$$t_e=L/R$$

Where L is inductance (henries) and R is resistance (ohms).

Encoder

A feedback device that converts mechanical motion into electronic signals. The most commonly used rotary encoders output digital pulses corresponding to incremental angular motion. For example, a 1000-line encoder produces 1000 pulses every mechanical revolution. The encoder consists of a glass or metal wheel with alternating transparent and opaque stripes, detected by optical sensors to produce the digital outputs.

Feedback

A signal which is transferred from the output back to the input for use in a closed loop system.

Form Factor

The ratio of RMS current to average current. This number is a measure of the current ripple in a SCR or other switch-mode type of drive. Because motor heating is a function of RMS current while motor torque is a function of average current, a form factor greater than 1.00 means some fraction of motor current is producing heat but not torque.

Four Quadrant

Refers to a motion system which can operate in all four quadrants, i.e., velocity in either direction and torque in either direction. This means that the motor can accelerate, run and decelerate in either direction.

Friction

A resistance to motion caused by contact with a surface. Friction can be constant with varying speed (Coulomb friction) or proportional to speed (viscous friction).

Hall Sensor

A feedback device which is used in a brushless servo system to provide information for the amplifier to electronically commutate the motor. The device uses a magnetized wheel and Hall effect sensors to generate the commutation signals.

Holding Torque

Holding torque (sometimes called static torque) specifies the maximum external torque that can be applied to a stopped, energized motor without causing the rotor to move. Typically used as a feature specification when comparing motors.

Horsepower

A unit of measure of power. One horsepower is equal to 746 watts. The measurement of rotary power must take speed and torque into account. Horsepower is a measure of a motor's torque and speed capability. The formula is:

$$\text{HP} = \text{Torque (lb-in.)} \times \text{Speed (RPM)} / 63,025$$

$$\text{HP} = \text{Torque (lb-ft.)} \times \text{Speed (RPM)} / 5,252$$

$$\text{HP} = \text{Volts} \times \text{Amps} \times \text{Efficiency} / 746$$

Inductance (L) (mH - millihenries line-to-line)

The property of a circuit that has a tendency to resist current flow when no current is flowing, and when current is flowing has a tendency to maintain that current flow. It is the electrical equivalent to mechanical inertia.

Inductance (mutual)

Mutual inductance is the property that exists between two current-carrying conductors (or coils) when a change in current in one induces a voltage in the other.

Inertia

The property of an object to resist change in velocity unless acted on by an outside force. Higher-inertia objects require larger torques to accelerate and decelerate. Inertia is dependent on the mass and shape of the object.

Inertial Match

The reflected inertia of the load is equal to the rotor inertia of the motor. For most efficient operation, a system coupling ratio should be selected that provides this condition.

Open-loop

A system in which there is no feedback. Motor motion is expected to faithfully follow the input command. Stepping motor systems are an example of open-loop control.

Overload Capacity

The ability of a drive to withstand currents above its continuous rating. It is defined by NEMA (National Electrical Manufacturers Association) as 150% of the rated full-load current for "standard industrial DC motors" for one minute.

Peak torque (T_{pk}) (lb-in.)

The maximum torque a brushless motor can deliver for short periods of time. Operating permanent-magnet motors above the maximum torque value can cause demagnetization of the rare-earth magnets. This is an irreversible effect that will alter the motor characteristics and degrade performance. It is also known as peak current. This should not be confused with system peak torque, which is often determined by amplifier peak-current limitations, where peak current is typically two times continuous current.

Poles

Refers to the number of magnetic poles arranged on the rotor of the brushless motor. Unlike an AC motor, the number of poles has no direct relationship to the base speed of the motor.

Power

The rate at which work is done. In motion control, power is equal to torque multiplied by speed.

Power (watts) = force x distance/time

Power = voltage x current

Power Factor

Ratio of true power (kW) to apparent power (kVA).

Pulse Rate

The frequency of the step pulses applied to a step motor driver. The pulse rate, multiplied by the resolution of the motor/driver combination (in steps per revolution), yields the rotational speed in revolutions per second.

Pulse Width Modulation (PWM)

Describes a switch-mode (as opposed to linear) control technique used in amplifiers and drivers to control motor voltage and current.

Read / Read-Write

Read (or read-only): the system can read data from a file or device but not write data to the file or device.

Read-Write: the system can read data from or write data to a file or device.

Regeneration

The action during motor braking, in which the motor acts as a generator and takes kinetic energy from the load, converts it to electrical energy and returns it to the amplifier.

Repeatability

The degree to which a parameter such as position or velocity can be duplicated.

Resolution

The smallest increment into which a parameter can be broken down. For example, a 1000-line encoder has a resolution of 1/1000 of a revolution.

Resonance

Oscillatory behavior caused by mechanical or electromechanical harmonics and limitations.

Ringling

Oscillation of a system following a sudden change in state.

RMS Current - Root Mean Square Current

In an intermittent duty-cycle application, the RMS current is equal to the value of steady state current that would produce the equivalent motor heating over a period of time.

RMS Torque - Root Mean Square Torque

In an intermittent duty-cycle application, the RMS torque is equal to the value of steady state torque that would produce the equivalent motor heating over a period of time.

Rotor

The moving part of the motor, consisting of the shaft and magnets. These magnets are analogous to the field winding of a brush-type DC motor.

Settling Time

The time required for a parameter to stop oscillating or ringing and reach its final value.

Speed

Describes the linear or rotational velocity of a motor or other object in motion.

Stall Torque

The amount of torque developed with voltage applied and the shaft locked or not rotating. Also known as locked-rotor torque.

Stator

The nonmoving part of the motor. Specifically, it is the iron core with the wire winding in it that is pressed into the frame shell. The winding pattern determines the voltage constant of the motor.

Stiffness

The ability to resist movement induced by an applied torque. Stiffness is often specified as a torque displacement curve, indicating the amount a motor shaft will rotate upon application of a known external force when stopped.

Torque

A measure of angular force which produces rotational motion. This force is defined by a linear force multiplied by a radius, e.g., lb-in. The formula is:

$$\text{Torque (lb-ft.)} = 5,250 \times \text{HP/RPM}$$

Torque Constant (KT = lb-ft./A)

An expression of the relationship between input current and output torque. For each ampere of current, a fixed amount of torque is produced.

NOTE: Torque constants *are not* linear over the operating range of a motor. They apply best at approximately 75% of no-load maximum speed or where the peak and continuous torque curves meet.

Torque-to-Inertia Ratio

Defined as the motor's holding torque divided by the inertia of its rotor. The higher the ratio, the higher a motor's maximum acceleration capability will be.

Velocity

The change in position as a function of time. Velocity has both a magnitude and sign.

Voltage Constant (KE) (V/kRPM peak, line-to-line)

May also be termed Back-EMF constant. When a motor is operated, it generates a voltage proportional to speed but opposing the applied voltage. The shape of the voltage waveform depends on the specific motor design. For example, in a brushless motor, the wave shape may be trapezoidal or sinusoidal.

Revision History

August 2016

- Initial release

November 2016

- Added Revision History page
- Updated Copyright page contact info for new offices

November 2017

- Fixed some minor typos
- Updated some external links to open in a separate window
- Reformatted document to support mobile output in addition to PDF

August 2018

- Added SmartMotor Success Checklist topic
- Updated Copyright date

October 2018

- Modified shunts warning

January 2019

- Modified relative humidity spec to "<85% and noncondensing"
- Some additional style changes to support mobile output

April 2020

- Modified contact info on the Copyright page.
- Updated covers, body text, table text, captions text, and notes, cautions, warnings text to IG fonts (Apex Sans). NOTE: This was strictly a cosmetic change.

June 2021

- Added topic on motor mounting.

June 2022

- Added NOTE about resetting PC to DHCP after completing comms with IE motor(s).
- Other minor edits.

--- NOTES ---

TAKE A CLOSER LOOK

Moog solutions for a wide variety of applications, including medical, office automation, packaging, industrial, aerospace and defense are only a click away. Visit our worldwide web site for more information.

Americas - West
Moog Animatics
2581 Leghorn Street
Mountain View, CA94043
United States

Tel: +1 650-960-4215
www.animatics.com

Americas - East
Moog Animatics
1995 NC Hwy 141
Murphy, NC 28906
United States

Tel: +1 828-837-5115
www.animatics.com

Europe
Moog GmbH
Allgaeustr. 8a
87766 Memmingerberg
Germany

Tel: +49 (0) 8331 98 480-0
www.animatics.de

Asia
Moog Animatics
Kichijoji Nagatani City Plaza 4F
1-20-1, Kichijojihoncho
Musashino-Shi, Tokyo 180-0004
Japan

Tel: +81 (0) 422 201251
www.animatics.jp

For product information, visit www.animatics.com

For more information or the office nearest you, contact us online, animatics_sales@moog.com

Moog is a registered trademark of Moog Inc. and its subsidiaries.
All trademarks as indicated herein are the property of Moog Inc. and its subsidiaries.
©2016-2022 Moog Inc. All rights reserved. All changes are reserved.

Moog Animatics System Best Practices Application Note, Revised: 06/23/2022
PN: SC801000??-001