

- NOTES: 1) TIED INTERNALLY: TX : CN2 PIN 10 TO CN1 PIN 3  
 RX : CN2 PIN 11 TO CN1 PIN 4  
 2) TIED INTERNALLY: +5V : CN2 PIN 12 TO CN1 PIN 2  
 GND : CN2 PIN 13, CN2 PIN 14 AND CN1 PIN 5 TIED TO CN1 PIN A2  
 PWR : CN2 PIN 15 TO CN1 PIN A1  
 3) FOR HIGH SPEED OR HIGH TORQUE OPERATION USE POWER  
 PIN A1 AND A2 ON CN1.

MODEL	LENGTH
SM3410D	3.488
SM3420D	4.138
SM3430D	4.788
SM3440D	5.438
SM3450D	6.088

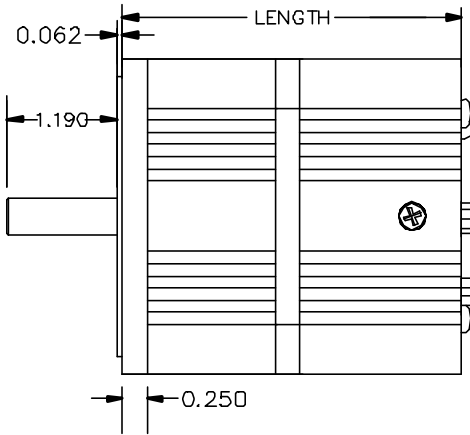
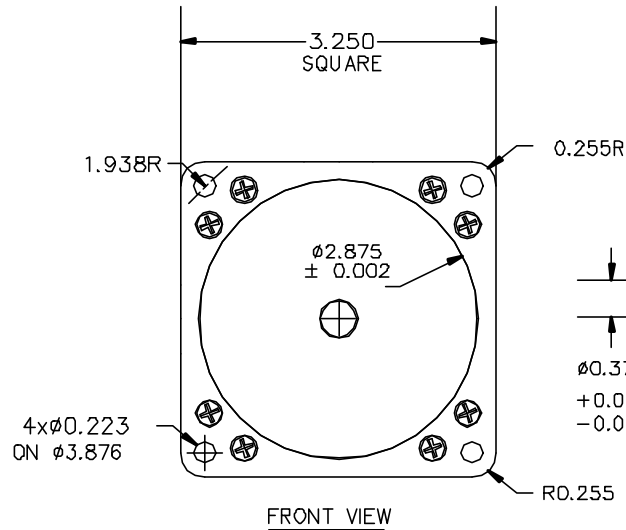

LED, TRAJECTORY  
 CLEAR= NOT IN TRAJECTORY [DEFAULT STATE]  
 GREEN= IN A CONTROLLED TRAJECTORY (MOTION)

LED, SERVO-AMPLIFIER  
 RED=AMPLIFIER OFF [DEFAULT STATE]  
 GREEN=AMPLIFIER ON OR SERVO-ING IN PLACE

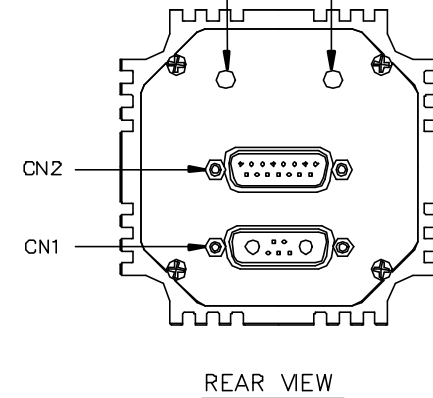

DRAWING SCALE: 1:2

CN2: 15 PIN D-SUB FEMALE CONNECTOR					
PIN#	NAME	SOFTWARE SELECTABLE FUNCTIONS			
		SPECIAL FUNCTIONS	SPECIAL FUNCTIONS	DIGITAL I/O (TTL)	ANALOG INPUT (10 bit)
1	Port A	External Encoder A Input	Step Input	5V	0 to 5V
2	Port B	External Encoder B Input	Direction Input	5V	0 to 5V
3	Port C	Right Limit Input		5V	0 to 5V
4	Port D	Left Limit Input		5V	0 to 5V
5	Port E	AniLink Data	RS-485 Signal A	5V	0 to 5V
6	Port F	AniLink Clock	RS-485 Signal B	5V	0 to 5V
7	Port G	G-Synchronization Pin	RS-485 Adapter Flow Control Line	5V	0 to 5V
8	ENCA OUT	Encoder A Output			
9	ENCB OUT	Encoder B Output			
10	RS232 TX	RS232-Transmit			
11	RS232 RX	RS232-Receive			
12	+5V OUT	+5V Out			
13	GND	Signal Ground			
14	PWR GND	Power Ground			
15	POWER	Power, +24v to 48v			

CN1: 7 PIN COMBO D-SUB MALE CONNECTOR		
PIN#	NAME	FUNCTIONS
1	Part G	G-Synchronization Pin
2	+5V OUT	+5V Out (Note 2)
3	RS232 TX	RS232-Transmit
4	RS232 RX	RS232-Receive
5	GND	Signal Ground
A1	POWER	Power, +24v to 48v
A2	PWR GND	Power Ground

TITLE: SM3400D SERIES	
REV: 2	MATERIAL:
DATE: 2/27/01	FINISH:
TOL: X.XXXX +/- .005 INCHES X.XXX +/- .005 X.XX +/- .01 UNLESS OTHERWISE NOTED	ANIMATICS CORPORATION 3050 TASMAN DR. SANTA CLARA