



# HIGHLY INTEGRATED MOTION CONTROL PRODUCTS CATALOG

COMPLETE SOLUTIONS -- INCLUDING SERVOMOTORS WITH  
EMBEDDED MOTION AND MACHINE CONTROLLERS,  
AND FULLY INTEGRATED LINEAR AND ROTARY ACTUATORS

WHEN PERFORMANCE REALLY MATTERS®

**MOOG**  
 ANIMATICS

Thank you for your interest in our innovative automation solutions. Since its founding in 1987, Moog Animatics has delivered upon a unique approach to motion and machine control that enables you to leapfrog your global competition. Moog Animatics is the world leader in fully integrated servo technology and is part of Moog Inc., a worldwide designer, manufacturer, and integrator of precision motion control products and systems. Moog's high-performance systems control military and commercial aircraft, satellites and space vehicles, launch vehicles, missiles, industrial machinery, wind energy, marine applications, and medical equipment.

Moog Animatics offers the most advanced highly integrated automation solutions in the industry. Starting with the SmartMotor™, the world's first fully integrated servo system, and extending through a large variety of I/O, machine control, software, and integrated actuator products, Moog Animatics offers total solutions with a much smaller footprint, a lower total cost and a simplicity that reduces your machine development and build time – getting you to market faster.

With offices in Tokyo, California, New York, Pennsylvania and Continental Europe, the sun never sets on Moog Animatics while we directly support key customers along with a global network of factory trained Automation Solution Providers; independent companies in your backyard ready to supply and support your Moog Animatics products through the long haul.

This catalog contains all Class 5 and Class 6 SmartMotor products, software, and Moog Animatics' actuator line (linear integrated systems). All of the SmartMotor servos in this catalog have the latest feature set and are recommended for new designs.

Many new products are highlighted in this catalog, including our Class 6 EtherNet/IP™ SmartMotor that is available in both standard servo and hybrid versions. The new product represents the next step in the evolution of the Class 6 integrated motor design, which includes PROFINET® and EtherCAT® versions, and extends the robust, dual-port industrial Ethernet SmartMotor with EtherNet/IP™ Position Controller capability.

Our expanded linear actuator offerings include low-backlash, high-precision, belt-driven rotary stage units, true belt-driven linear systems, and combination H-Bot and T-Bot units for high-precision, two-axis motion. All units come integrated with your choice of SmartMotor.

Our exciting firmware advances include I/O device CAN Bus Master capability, sophisticated custom spooling pattern capabilities for traverse and take-up winding applications, and DMX Protocol for a wide variety of entertainment automation applications.

In need of a custom solution for your motion control challenge? Please contact us and let us show you innovative, compact, and highly effective ideas that are optimally engineered to help you gain competitive advantage and win in your market.

Thank you again and welcome to Moog Animatics, *When Performance Really Matters*®.

---

We define the future of motion control by innovation, invention, and a dedication to the highest standards of professionalism and quality in everything we do and in every product that we make.

We invite quality firms to ally with us and to participate in our inventions and innovations for the benefit of the companies that need and use our advanced technology and products.

We invite our customers and users to join with us in the joint development of custom products and systems using our technology.

We commit to providing a fair workplace for our employees. We subscribe to the principle of being a good corporate citizen, a good neighbor, and a protector of our environment.



***When Performance Really Matters***®

Latest from Moog Animatics .....	4
<b>Overview</b>	
I/O Device CAN Bus Master and Combitronic™ Communications .....	5
<b>Software</b>	
Software .....	6
<b>Class 5 D-Style</b>	
Class 5 Overview .....	8
D-Style Motor — Understanding Part Numbers .....	9
D-Style Motor Comparison Chart .....	10
D-Style Motor Torque Curves .....	12
D-Style Motor CAD Drawings .....	14
Class 5 D-Style Connector Pinouts .....	16
Fieldbus Protocol Options .....	17
CDS7 Option and Recommended DE Option .....	18
<b>Class 5 M-Style</b>	
Industrial M-Style SmartMotor with Optional IP-Rating .....	19
Class 5 M-Style Motor Comparison Chart .....	20
M-Style Torque Curves and Motor CAD Drawings .....	21
M-Style Connector Pinouts .....	22
<b>Class 6 M-Style</b>	
Class 6 Industrial Ethernet .....	23
Class 6 Specifications .....	24
Class 6 Torque Curves .....	25
Class 6 Drawings .....	26
Class 6 M-Style Connector Pinouts .....	27
<b>Cables and Peripherals</b>	
Cables and Accessories .....	28
Boards and Test Interfaces .....	30
<b>Actuators</b>	
Linear Actuators Overview .....	31
Linear Actuators — Understanding Part Numbers .....	32
Linear Actuator Comparison Chart .....	33
Belt-Driven Linear Actuators — PSC .....	35
Belt-Driven Linear Actuators — M6S .....	36
Rotary Actuators — ROT1 .....	37
Horizontal Two-Axis Gantry System — HBOT1 .....	38
<b>Gearheads</b>	
Introduction to Gearheads .....	39
Planetary Gearheads — NEMA 17 Series .....	40
Planetary Gearheads — NEMA 23 Series .....	41
Planetary Gearheads — NEMA 34 Series .....	42
Right Angle Planetary Gearheads .....	43
<b>Power Supplies and Shunts</b>	
How to Choose Power Supplies .....	44
Open Frame Linear Unregulated DC Power Supplies .....	45
Enclosed Switch Mode DC Power Supply .....	46
Enclosed DC Power Supplies .....	47
Introduction to Shunts .....	48
Open Frame and Enclosed Shunts .....	49
NOTES .....	50
NOTES .....	51

Notice: All SmartMotor™, actuator and product specifications are subject to change without notice.

Consult website or factory for latest data.

Declaration of Conformity ([www.animatics.com/conformity](http://www.animatics.com/conformity))

Warranty Statement ([www.animatics.com/warranty](http://www.animatics.com/warranty))

Technical Support: 888-356-0357

## Class 6 Industrial Ethernet SmartMotors

Support EtherNet/IP™, PROFINET® and EtherCAT® protocols

- NEMA 23 frame in standard (MT) and high pole count (MH) versions
- High-end, high-speed processor for exceptional performance
- Compact, feature-rich controls allow for rapid solution development

See page 23 for details.



## M6S/PSC Linear and ROT1 Rotary Actuators

SmartMotor powered belt-driven actuators

- Delivered as a turnkey solution
- Low backlash, high positional accuracy and long service life
- Motor mounting options for maximum design and mounting flexibility

See page 35-page 37 for details.

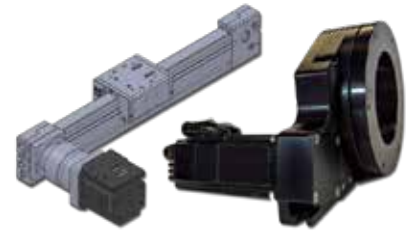

## T-Bot and H-Bot Systems

SmartMotor powered turnkey gantry systems

- Low backlash belt actuators with stationary SmartMotors
- Shipped preassembled with the SmartMotors of your choice
- Precise and accurate horizontal or vertical positioning for low to medium loads

See page 38 for details.



## I/O Device CAN Bus Master

Interfaces with standard CiA 301 CANopen devices

- Multiple SmartMotors and multiple I/O devices on the same CAN bus
- Support for both PDO and SDO protocols (some limitations apply)
- SmartMotor achieves FULL machine control -- no other HMI or bus master required!

See page 5 for details.

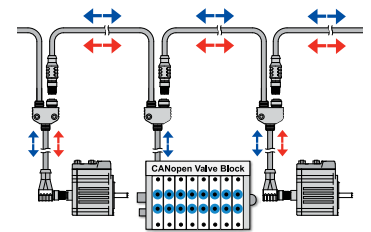

## Expanded Traverse and Takeup

Now supports complex winding patterns

- Overlay camming profiles onto traversing profiles for complex patterns
- Prevent material from becoming tangled or trapped when unwinding
- **Auto Reverse and Electronic Gearing** profiles for the **perfect pool** every time

See website Case Studies and SmartMotor Developer's Guide for details.

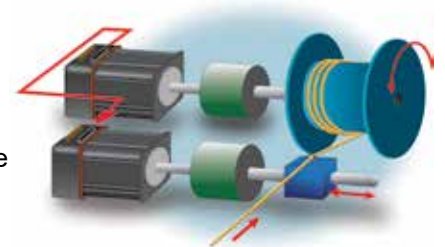

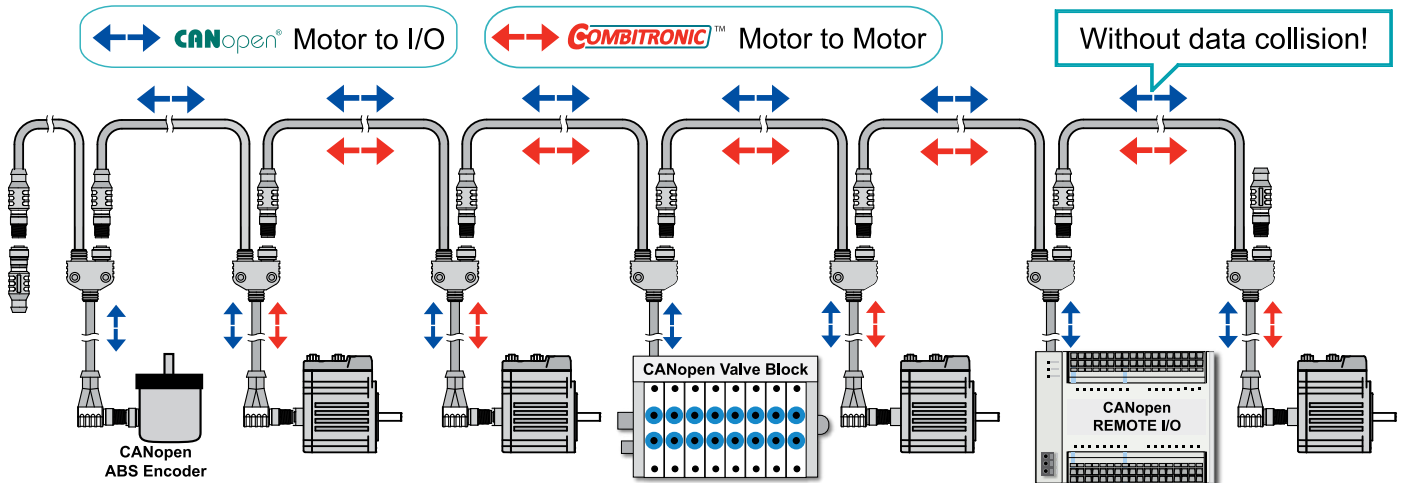

Be sure to follow proper guidelines for CAN bus cabling and termination.

**I/O Device CAN Bus Master - SmartMotors can now interface with standard CiA 301 CANopen devices including but not limited to:**

- Remote digital/analog/mixed signal I/O
- CAN bus absolute or relative encoders
- Inclinometers
- Load cells
- Temperature controllers
- Pneumatic valve blocks
- And more

Basic control allows 8, 16, or 32-bit sized data objects with support for both PDO and SDO protocols. The supported profiles include but are not limited to I/O profile, encoder profile, and DS4xx profile. This provides the ability to:

- Dynamically map SmartMotor PDOs, map another device's PDOs, start the NMT state
- A SmartMotor can send/receive up to 5 PDOs each for RX (Receive) and TX (Transmit)
- Read/write SDOs in expedited mode only; which works up to 32-bit data

Multiple SmartMotors and multiple I/O devices may be on the same CAN bus. This combined with Combitronic motor-to-motor communications allows for complex, multi-axis, multi-I/O-device network control. **Now you can achieve full machine control with just the SmartMotors -- no other HMI or bus master is required!**

**COMBITRONIC™ High-Speed Communications** is a protocol that operates over a standard "CAN" (Controller Area Network) interface. It may simultaneously coexist with either CANopen or DeviceNet protocols. Unlike these common protocols however, Combitronic™ requires no single dedicated master to operate. Each integrated servo connected to the same network communicates on an equal footing, sharing all information, and therefore, sharing all processing resources.

**Combitronic protocol features:**

- 120 axis node count
- 1 MHz bandwidth
- No master required
- No scan list or node list set up required
- All nodes have full read/write access to all other nodes



Combitronic™ technology allows any motor's program to read from, write to, or control any other motor simply by tagging a local variable or command with the other motor's CAN address. All SmartMotors become one multi-tasking, data-sharing system without writing a single line of communications code or requiring detailed knowledge of the CAN protocol. The only prerequisite is to have matched baud rates and unique addresses.

For more details, see [animatics.com/combi](http://animatics.com/combi)

**Combitronic technology enables standalone multi-axis linear interpolation:**

```

a=1 b=2 c=3      'Motor addresses, x, y and z
x=123000        'X Axis Target Position
y=20000         'Y Axis Target Position
z=8000          'Z Axis Target Position
PTS(x;a,y;b,z;c) 'Set 3-axis synchronized target position
GS              'Go, 3-axis linear interpolation
TSWAIT         'Wait until 3 axis move is complete
    
```





## SmartMotor Interface (SMI)

Moog Animatics' SMI™ Version 3 software provides an easy-to-use Microsoft Windows compatible interface to your Moog Animatics SmartMotor™. Using SMI, you can define multi-axis motion control for 1 to 120 SmartMotors. SMI includes a terminal program, program editor, and source level debugger. Standard SMI features include a Tools menu to set PID tuning parameters and plot the step response, motor info and dynamic status tracking, and online help and documentation. The SMI software can also open multiple windows for program editing, instantly address multiple motors, and upload programs.

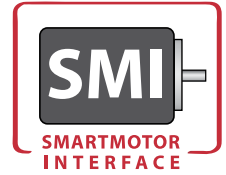

Free Download from Website: [www.animatics.com/smi](http://www.animatics.com/smi)

### Key Features in Version 3

- New Program Editor includes undo/redo commands and group tabbing for more efficient programming
- SmartMotor fieldbus network view and extended CANopen support for smoother fieldbus integration
- Context Sensitive Help for instant access to full keyword descriptions
- Revised help system provides documentation access when working online or offline
- Preprocessor Extension for specifying include files, defining macros, and more, to speed application development
- And much more...refer to the website/factory for details

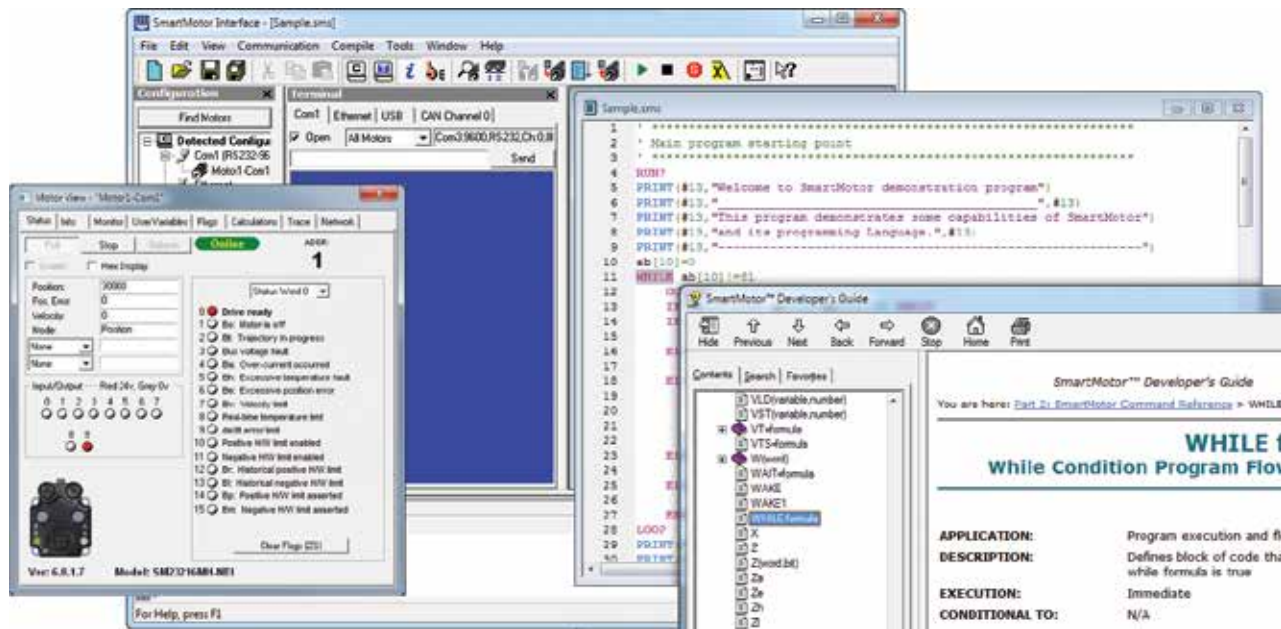

## SMIEngine

Moog Animatics' SMIEngine™ is a source code module library created as a software tool for the Windows® operating system environment. It comes free with the installation of SMI software (see above). The installation includes source code examples. SMIEngine is based on the Windows® Component Object Model (COM) and works with:

- Microsoft® C++, Visual Basic, .NET environment
- Borland® C++ and Delphi
- VBA (Visual Basic for Applications)
- Pascal
- Python™
- LabVIEW™ (when installed as an ActiveX component)

Using SMIEngine, you can perform tasks such as:

- Detecting motors on the desired port
- Addressing a SmartMotor™ daisy chain
- Sending commands to the motors and getting the motor responses
- Downloading/uploading compiled user programs (".smx" files) to/from the motors
- Controlling the motors using coordinated motion (contouring or host mode)
- Creating circular and linear path coordinates used for coordinated motion
- Scanning user program source files (".sms") for errors
- Creating a list of errors in a user program and providing an interface for navigating through errors
- And much more...refer to the website/factory for details

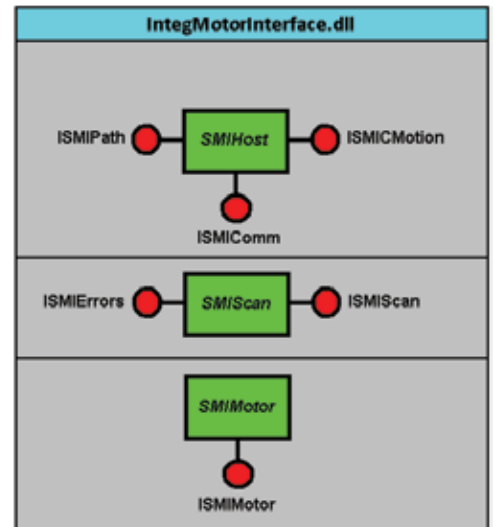

Free download from website!

## Smart Sizer

Moog Animatics SmartSizer™ is a load sizing software tool to aid in SmartMotor selection for any given load. In a simple single-page format, the tool allows the user to fill in values to calculate load torque imposed on a given motor. All input data has a unit selector that allows you to easily mix and match standard and metric units.

### ! WARNING

SmartSizer™ is a software tool to aid in determining load torque that would be imposed onto a given motor shaft. It is up to the user to ensure proper servo motor sizing and power supply sizing to prevent over loading damage. Moog Animatics is not responsible for motor sizing.

## SMNC

SMNC™, Moog Animatics' G-code based servo motion control software, uses numeric control to deliver multi-axis contouring for your Moog Animatics SmartMotor™ applications. SMNC provides a set of features that are comparable to any CNC system, including a user interface that is similar in appearance to a traditional CNC system.

SMNC features include:

- Linear and circular motion control of multiple axes
- Configures SmartMotors across multiple serial ports
- Converts CAD (DXF) files into motion control G and M codes
- Duplication of axis motion for gantry systems
- Smooth control of acceleration and deceleration for sensitive curvilinear motion
- And much more...refer to the website/factory for details

## AniCNC™

AniCNC™ is Moog Animatics' newest CNC application software exclusively for use with the Class 5 SmartMotor™. When coupled with the Class 5 SmartMotor, the AniCNC product provides a graphical Human-Machine Interface (HMI), G-code editing and runtime environment and other built-in features to help you quickly tackle your milling, routing, machining, shaping and related projects. There's even an offline mode that lets you preview and refine your G-code tool paths without being attached to the SmartMotor.

AniCNC™ features include:

- A simple, intuitive user interface, optimized for touchscreen use
- Advanced Code Writer and Shape Writer for creating complex patterns
- DXF file import to produce scalable G-code for quick resizing and/or arraying of your design
- G-code export to DXF format for efficient use in CAD or illustration software
- G-code editing and runtime environment with real-time viewing of the tool path
- TrueType font to G-code converter allows you to scale/frame text as desired
- Built-in functions for point-and-click programming of common metalwork shapes
- Nested-array code building for easy duplication of parts in sheet material
- Dynamic jog and teach to rapidly record points to the G-code program
- In-path jog correction allows temporary move adjustment and then resets and continues

Motor	Cont. Tq.(m-nm)	Peak Tq.(m-nm)	Max. Speed(RPM)	Cont. Power(Watt)
SM1705D	33.26	61.12	7900	149.1
SM21155D	40	64	10400	171.5
SM21165DT	73.76	118.4	5200	201.3
SM3165DT	154.72	232.02	5100	238.6
SM3165DT	235.20	352.80	5100	310.9

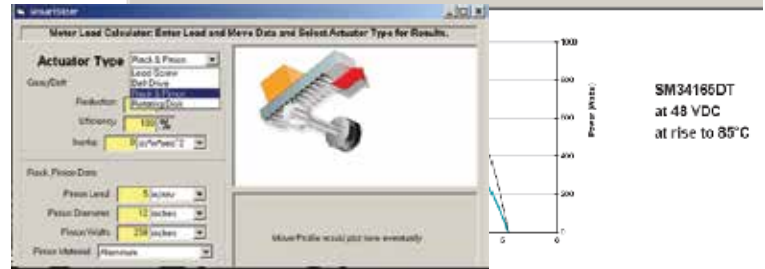

Included in free SMI download from website!

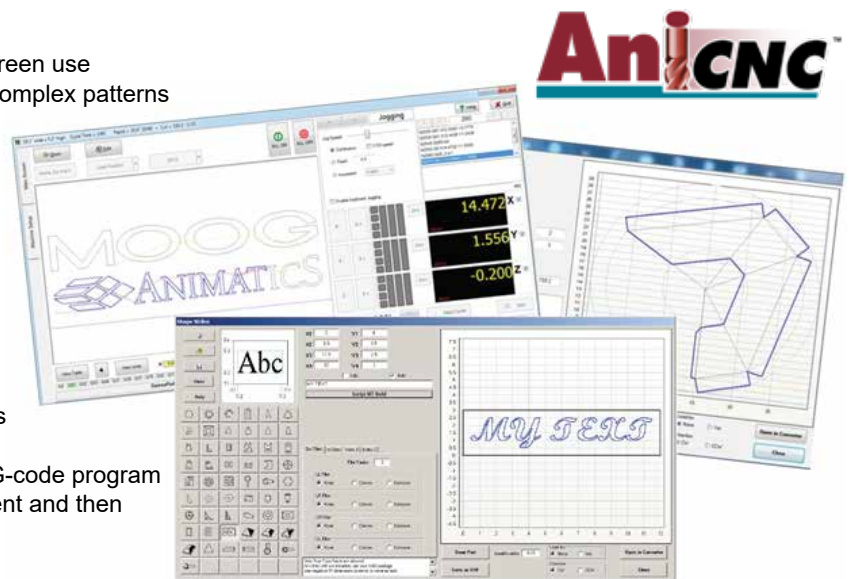
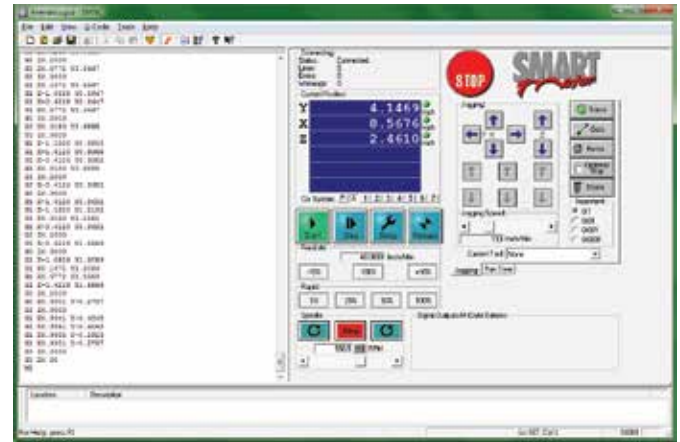

Overview  
Software  
C5 D-Style  
C5 M-Style  
C6 M-Style  
C6 Low-Cost  
Cables, Etc.  
Actuators  
Gearheads  
Power Supplies

### Class 5 Control Overview

- Faster processor, over five times faster than previous generation motors
- Faster RS-232 / RS-485 communications speeds, up to 115.2 Kbaud for unparallelled connectivity
- Multi-port simultaneous communications, RS-232 / RS-485 / CAN Bus
- Enhanced Trap Mode Commutation
- Expanded Math Function capability with floating point math and trigonometric functions
- Modulo Encoder Count capability
- Eight priority-stacked, user-definable interrupts
- Four user-definable, independent timers
- DE/Dt: Following error limit rate of change
- Increased I/O interrupt assignments
- Software programmable limits can be set to trigger interrupts without fault
- Enhanced parameter and function-based syntax
- Increased system status bit registers for advanced diagnostics
- Optional onboard expanded I/O: 10 channels, 24 VDC isolated, assignable as inputs or outputs
- Optional 10 additional points of isolated 24V I/O; source up to 300 mA, and read both digital and analog signals
- Four times faster PID update rate (down to 62.5 µsec) enables ultra-precise motion
- Optional CANopen communications with high-speed contouring to sub-millisecond synchronization
- New Sinusoidal Commutation capability delivers smooth and quiet motion, even at low speeds
- Commutative, associative, and distributive math syntax
- Software programmable limits can be used as programmable electronic cam switch triggers
- Optionally communicate with the motor through the serial port, which provides access as a Modbus Remote Terminal Unit (RTU) Slave

### Enhanced Trap Mode and Sine Mode Commutation

The motors can be operated with encoder-based commutation that allows for a more precise alignment and association of rotor to stator magnetic phases. The result is a smooth, quiet rotation with very low cogging. As a result, much slower commanded speeds may be achieved with little speed fluctuation.

### Higher Frequency PID Update Rate

User selectable PID update rate defaults to 125 microseconds. Optionally, it may be decreased or increased. The faster 62.5 microsecond update rate allows for smoother high-speed operation and faster accel/decel correction under varying load conditions.

### Expanded Math Function Capability

Class 5 SmartMotor™ includes:

- Boolean operators such as exclusive OR and modulo
- Trigonometry functions: SIN, COS, TAN, ASIN, ACOS, ATAN
- Absolute value
- IEEE-754 single-precision floats
- Commutative and associative math operations with up to 128 characters on the right side of an equal sign

### Advantages Over Conventional Systems

- High noise immunity
- Low electrical noise emissions
- Very high tuning bandwidth (very stable)
- Very compact motion system (shortest axial length closed-loop servo available)

### DMX Protocol is Standard on Class 5

- Easily program the SmartMotor through DMX protocol
- Simple/advanced motion control triggered from DMX input
- No control cabinet = smaller machine footprint
- And much more...refer to the website/factory for details

Power and Encoder		
Drive Power	+20–48 VDC	
Control Power	+20–48 VDC (Must be supplied separately when DE option is ordered)	
Expanded I/O Option	+24 VDC Isolated (Must be supplied)	
Commutation	Trapezoidal (Default)	
	Enhanced Trapezoidal Based on Encoder Position	
	Sinusoidal	
Encoder Resolution	23 Frame: 4000 Counts per Revolution (Class 5)	
	34 Frame: 8000 Counts per Revolution (Class 5)	
Processor/Clocks		
Processor Clock Speed	32 MHz	
PWM Switching Frequency	16 KHz	
CPU Regulator Frequency	140 KHz +/-10% Load Dependent	
Drive Stage Regulator	100 MHz	
PID Update Rates		
PID1	16 kHz	62.5 µsec update rate
PID2 (Default)	8 kHz	125 µsec update rate
PID4	4 kHz	250 µsec update rate
PID8	2 kHz	500 µsec update rate
Programming		
Code	Command Interpretive Text Based	
Program	32 K Program / 32 K Data Storage	
Subroutines	Up to 1000	
Stack Pointers	10 Nested GOSUB( ) and/or Interrupt Calls	
Communications		
RS-232	2400 to 115200 Baud	9600 Default
RS-485	2400 to 115200 Baud	9600 Default
(Optional) CAN Bus	20 K to 1 MBaud	125000 Default



## Moog Animatics Class 5 D-Style SmartMotor™ Part Numbering Guidelines

### Basic Class 5 D-Style Part Numbering

**NEMA 17**



**NEMA 23**



**NEMA 34**



The Brake option cannot be used with any other option. 24V I/O can be used alone or in combination with other options. See part numbers below.

- SM17205D-BRK
- SM17205D-C
- SM17205D-DN
- SM17205D-AD1
- SM17205D-C-AD1
- SM17205D-DN-AD1

All three options (Brake, 24V I/O, CAN bus) are available in various combinations for the following part numbers.

- |           |          |
|-----------|----------|
| SM23375D  | SM23205D |
| SM23375DT | SM23305D |
| SM23105D  | SM23405D |

The Brake option cannot be used with any other option. 24V I/O can be used alone or in combination with other options. See part numbers below.

- |                 |                  |
|-----------------|------------------|
| SM23165D-C      | SM23165DT-C      |
| SM23165D-DN     | SM23165DT-DN     |
| SM23165D-AD1    | SM23165DT-AD1    |
| SM23165D-C-AD1  | SM23165DT-C-AD1  |
| SM23165D-DN-AD1 | SM23165DT-DN-AD1 |
| SM23165D-BRK    | SM23165DT-BRK    |

All three options (Brake, 24V I/O, CAN bus) are available in various combinations for the following part numbers.

- |             |          |
|-------------|----------|
| SM34165D**  | SM34205D |
| SM34165DT** | SM34305D |
| SM34105D    | SM34405D |

\*\*SM34165D and SM34165DT are the only models that can have an internal shunt.

To see all possible option combinations for each motor and get the exact part number, use the Part Number Generator available on the website at: <http://www.animatics.com/pngenerator>.

For the CDS7 option, see <https://pages.animatics.com/cds7-option>.

**NOTE: DMX protocol is standard on all Class 5 SmartMotors.**

### Advanced Class 5 D-Style Part Numbering

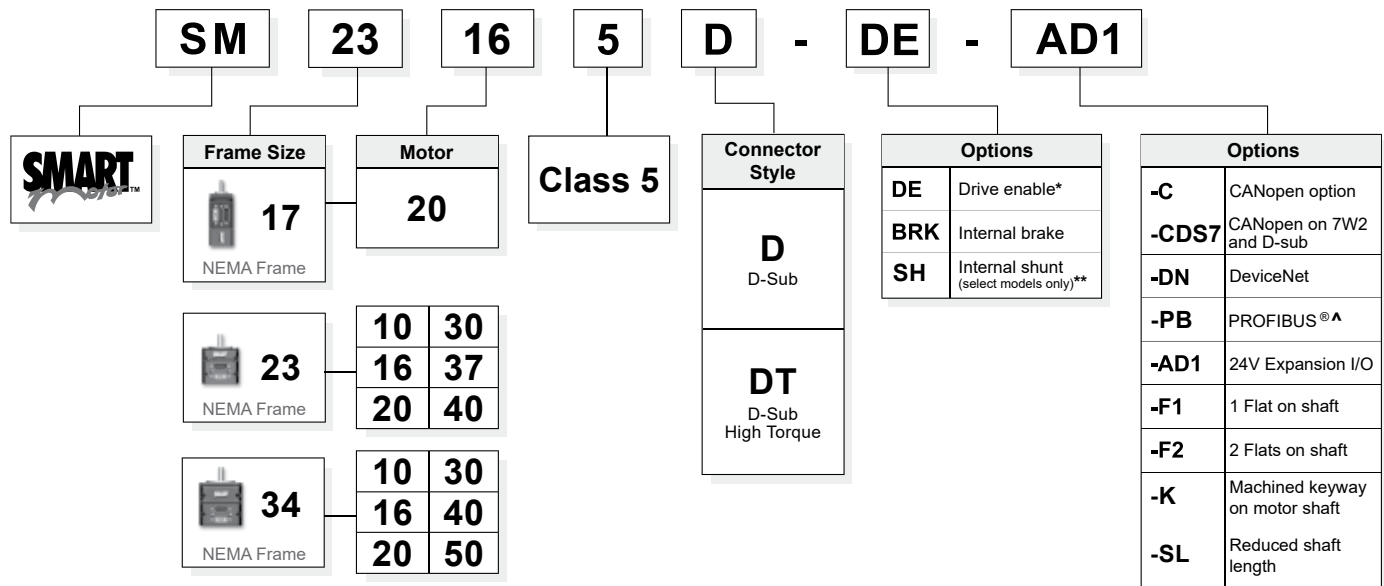

\* Separate drive and control power

\*\* SM34165D and SM34165DT are the only models that can have an internal shunt

^ PROFIBUS option only available on SM23165D and SM23165DT product with no additional options

**NOTE: DMX protocol is standard on all Class 5 SmartMotors.**

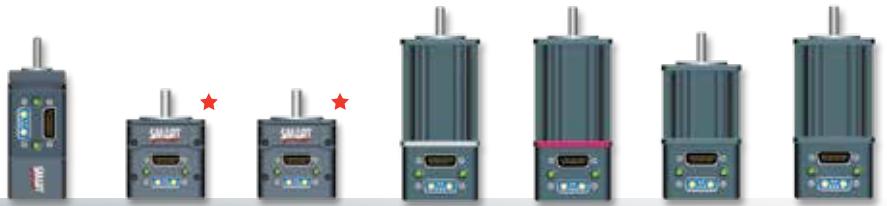

★ **BEST VALUE**

- All D-style SmartMotors have a primary RS-232 communications port
- All D-style SmartMotors have 7 channels 5V TTL non-isolated I/O
- Optional 10 channels expanded 24 VDC isolated I/O
- Dedicated encoder out

**Relative Torque Comparison**

NOTE: All torque curves based on 25°C ambient. For ambient temperatures above 25°C, continuous torque must be linearly derated to 0% at 85°C.

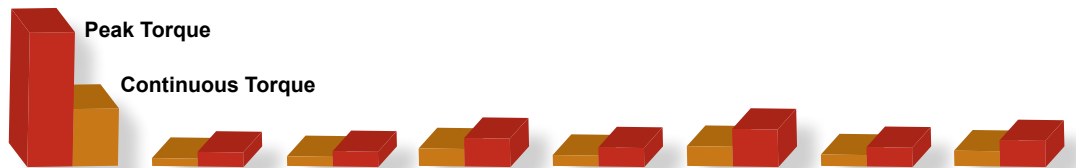

		SM17205D	SM23165D	SM23165DT	SM23375D	SM23375DT	SM23205D	SM23305D
<b>Continuous Torque</b>	in-lb	2.08	2.50	4.61	2.86	5.18	2.96	3.98
	oz-in	33	40	74	46	83	47	64
	N-m	0.24	0.28	0.52	0.32	0.59	0.33	0.45
<b>Peak Torque</b>	in-lb	3.82	4.00	7.40	5.00	9.80	5.03	6.86
	oz-in	61	64	118	80	157	80	110
	N-m	0.43	0.45	0.84	0.57	1.11	0.57	0.77
<b>Nominal Continuous Power</b>	Watts	145	181	204	191	186	226	220
<b>No Load Speed</b>	RPM	7,900	10,400	5,200	8,000	4,000	8,100	5,600
<b>Max. Continuous Current</b>	RPM	6,000	6,500	3,800	6,000	3,250	6,900	4,750
	Amps	3.81	4.70	5.074	5.072	4.52	6.02	5.57
<b>Peak Power</b>	RPM	4,200	6,100	3,400	4,750	2,450	5,995	4,100
	Watts	185	183	210	220	235	335	325
<b>Voltage Constant</b>	V/krpm	6.506	4.45	9.08	5.62	10.95	6.137	8.873
<b>Inductance</b>	mH	1.4	0.829	1.31	0.770	0.906	0.40	0.61
<b>Encoder Resolution</b>	Counts/Rev	4,000	4,000	4,000	4,000	4,000	4,000	4,000
<b>Rotor Inertia</b>	oz-in-sec <sup>2</sup>	0.00217	0.00099	0.001	0.0019	0.0019	0.00224	0.00332
	10 <sup>-5</sup> kg-m <sup>2</sup>	1.5325	0.6991	0.706	1.342	1.342	1.582	2.344
<b>Weight</b>	lb	1.2	1.0	1.3	2.1	2.2	1.7	2.3
	kg	0.55	0.45	0.59	0.95	0.98	0.79	1.03
<b>Shaft Diameter</b>	in	0.197	0.250	0.250	0.250	0.250	0.250	0.250
	mm	5.00	6.35	6.35	6.35	6.35	6.35	6.35
<b>Shaft, Radial Load</b>	lb	7	7	7	7	7	7	7
	kg	3.18	3.18	3.18	3.18	3.18	3.18	3.18
<b>Shaft, Axial Thrust Load</b>	lb	3	3	3	3	3	3	3
	kg	1.36	1.36	1.36	1.36	1.36	1.36	1.36
<b>DeviceNet Option</b>		Yes	Yes	Yes	Yes	Yes	Yes	Yes
<b>PROFIBUS Option</b>			Yes	Yes				
<b>CANopen Option</b>		Yes	Yes	Yes	Yes	Yes	Yes	Yes

Due to the variety of operating conditions and applications for Moog Animatics' products, the end user is solely responsible for making the final selection of the Moog Animatics products and systems based on their own analysis and testing, and ensuring that all performance, safety and warning requirements for the application and product are met. Please consult factory for any supporting hardware and cables needed, full details and latest information.



SM23405D	SM34165D	SM34165DT	SM34205D	SM34305D	SM34405D	SM34505D		
4.88	9.67	12.83	7.91	10.87	12.94	16.34	in-lb	<b>Continuous Torque</b>
78	155	205	126	174	207	261	oz-in	
0.55	1.09	1.45	0.89	1.23	1.46	1.85	N-m	
8.04	14.12	30.00	24.91	34.75	40.38	48.19	in-lb	<b>Peak Torque</b>
129	226	480	399	556	646	771	oz-in	
0.91	1.60	3.39	2.81	3.93	4.56	5.44	N-m	
253	235	615	324	400	438	527	Watts	<b>Nominal Continuous Power</b>
5,300	3,100	5,100	4,500	4,100	3,800	3,300	RPM	<b>No Load Speed</b>
4,500	2,400	4,500	3,750	3,600	3,300	3,100	RPM	<b>Max. Continuous Current</b>
6.76	6.02	16.93	8.28	10.31	11.69	14.37	Amps	
4,000	1,900	3,400	2,250	2,500	2,350	2,250	RPM	<b>Peak Power</b>
345	265	930	455	725	820	925	Watts	
9.612	14.98	8.9	10.8	12.1	12.9	14.049	V/krpm	<b>Voltage Constant</b>
0.49	1.72	0.32	0.596	0.490	0.913	0.871	mH	<b>Inductance</b>
4,000	8,000	8,000	8,000	8,000	8,000	8,000	Counts/Rev	<b>Encoder Resolution</b>
0.00439	0.014	0.0142	0.012	0.018	0.024	0.03	oz-in-sec <sup>2</sup>	<b>Rotor Inertia</b>
3.100	9.890	10.031	8.448	12.56	17.02	20.92	10 <sup>-6</sup> kg-m <sup>2</sup>	
2.8	5.0	5.5	3.5	4.5	5.5	6.5	lb	<b>Weight</b>
1.27	2.27	2.49	1.59	2.04	2.49	2.95	kg	
0.250	0.375	0.500	0.375	0.375	0.375	0.375	in	<b>Shaft Diameter</b>
6.35	9.53	12.70	9.53	9.53	9.53	9.53	mm	
7	15	30	15	15	15	15	lb	<b>Shaft, Radial Load</b>
3.18	6.80	13.61	6.80	6.80	6.80	6.80	kg	
3	3	3	3	3	3	3	lb	<b>Shaft, Axial Thrust Load</b>
1.36	1.36	1.36	1.36	1.36	1.36	1.36	kg	
Yes	Yes	Yes	Yes	Yes	Yes	Yes		<b>DeviceNet Option</b>
	Yes	Yes						<b>PROFIBUS Option</b>
Yes	Yes	Yes	Yes	Yes	Yes	Yes		<b>CANopen Option</b>

Due to the variety of operating conditions and applications for Moog Animatics' products, the end user is solely responsible for making the final selection of the Moog Animatics products and systems based on their own analysis and testing, and ensuring that all performance, safety and warning requirements for the application and product are met. Please consult factory for any supporting hardware and cables needed, full details and latest information.

- Overview
- Software
- C5 D-Style**
- C5 M-Style
- C6 M-Style
- C6 Low-Cost
- Cables, Etc.
- Actuators
- Gearheads
- Power Supplies

**SM17205D**

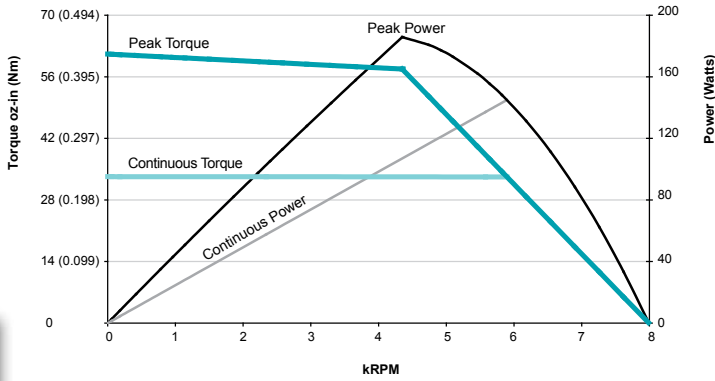

**SM23165D**

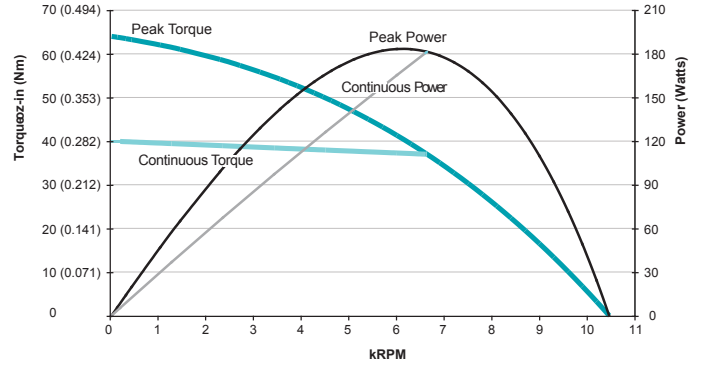

**SM23165DT**

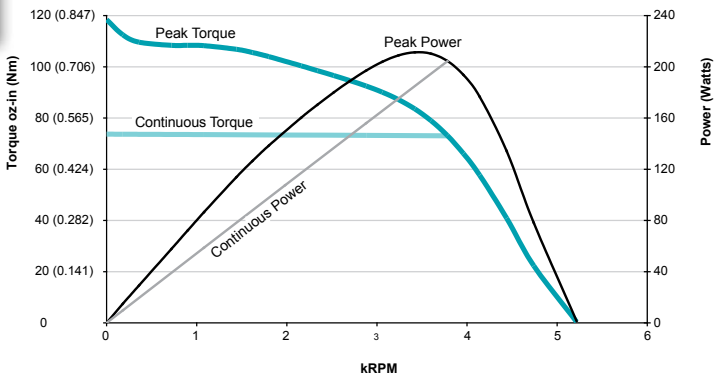

**SM23375D**

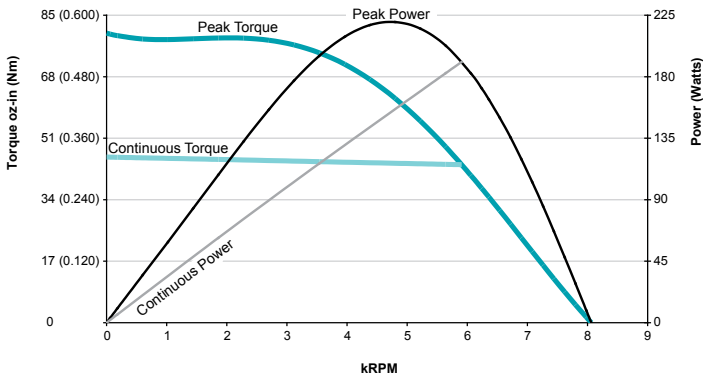

**SM23375DT**

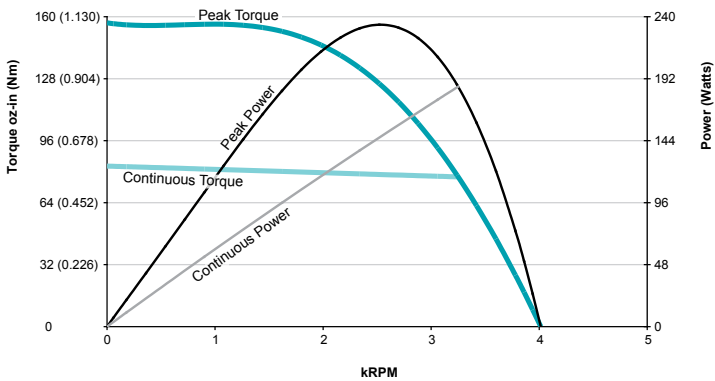

**SM23205D**

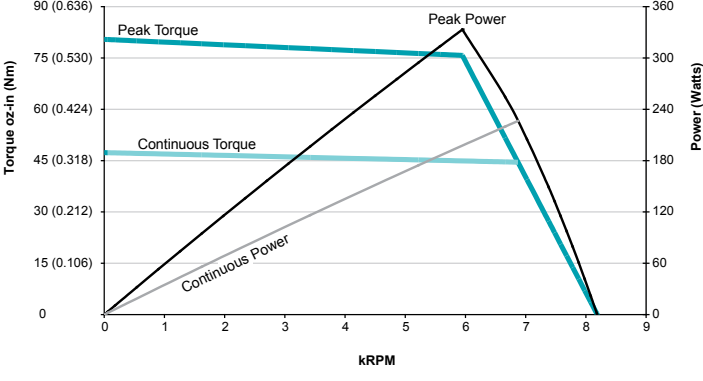

**SM23305D**

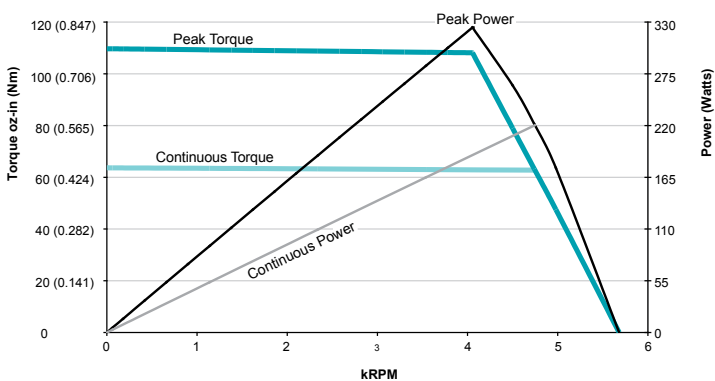

**SM23405D**

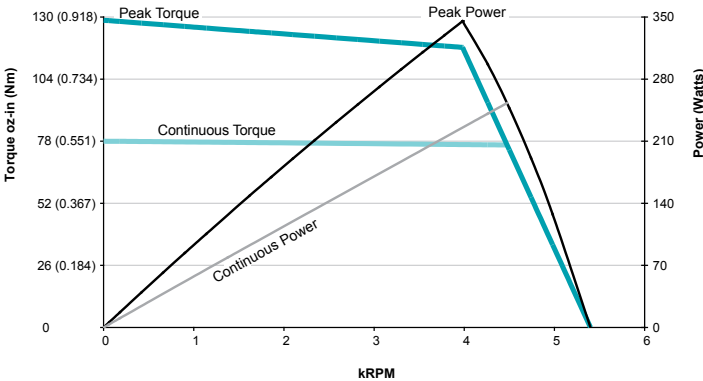



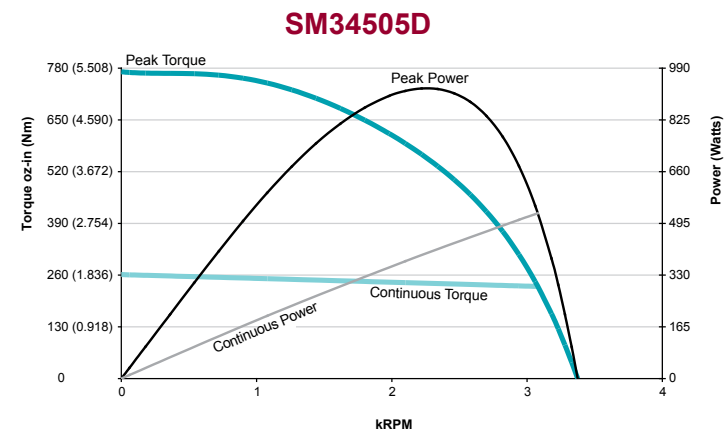
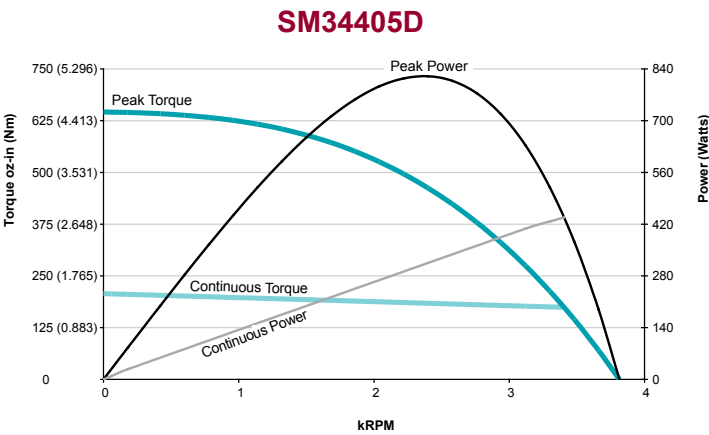
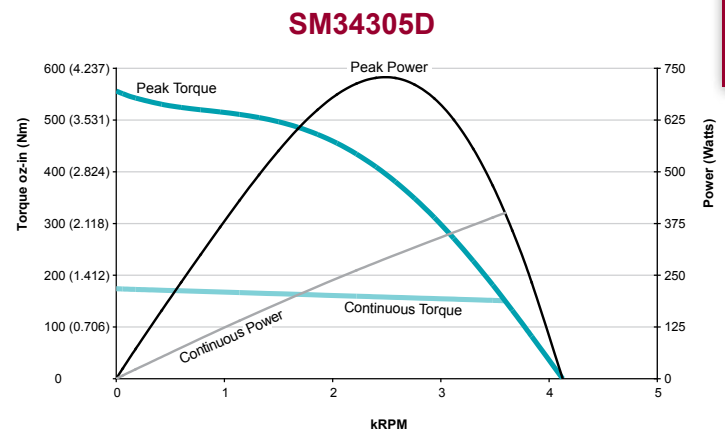
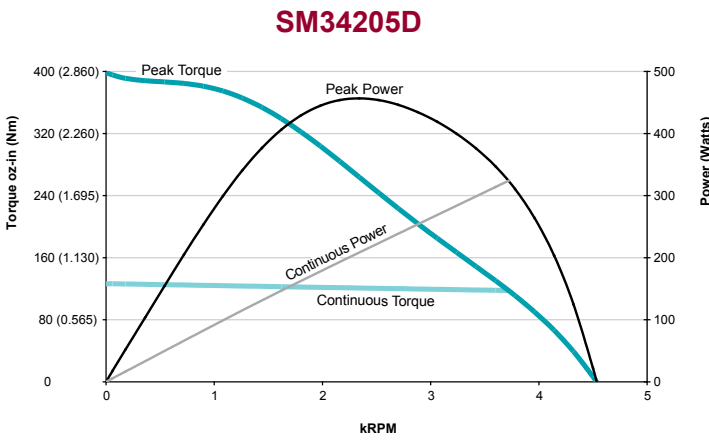
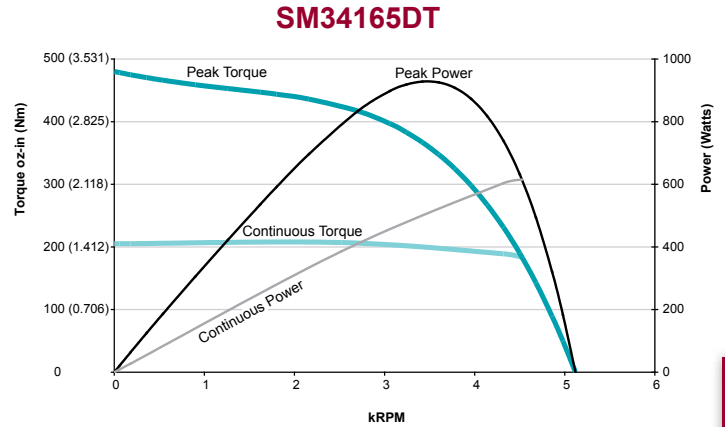
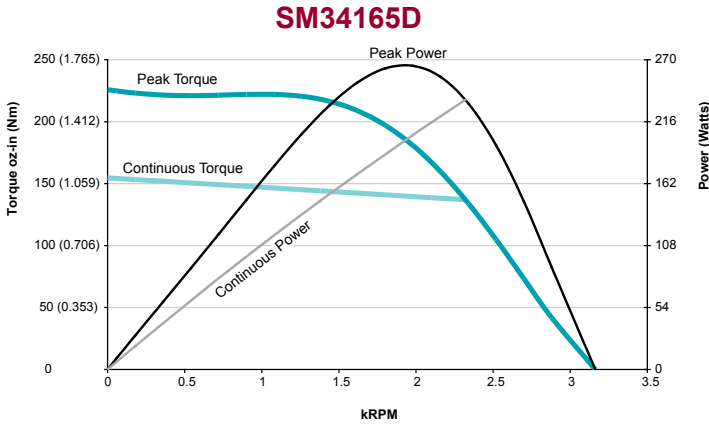

All torque curves based on 48 VDC at 25°C ambient with rise to 85°C.  
 Motors were operated using MDT (Trapezoidal Drive Mode) Commutation.  
 For ambient temperatures above 25°C, continuous torque must be linearly derated to 0% at 85°C.  
 Operating temperature range: 0°C – 85°C.  
 Storage temperature range: -10°C – 85°C, noncondensing.

- Overview
- Software
- C5 D-Style**
- C5 M-Style
- C6 M-Style
- C6 Low-Cost
- Cables, Etc.
- Actuators
- Gearheads
- Power Supplies

**SM17205D (No Options) CAD Drawing**

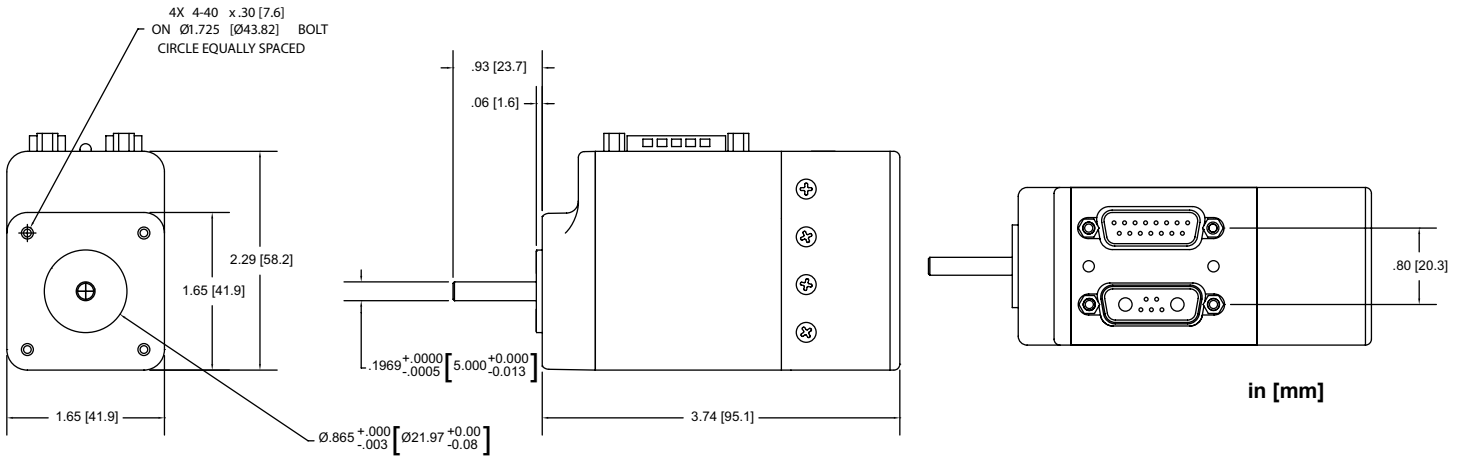

**SM23165D/DT (No Options) CAD Drawing**

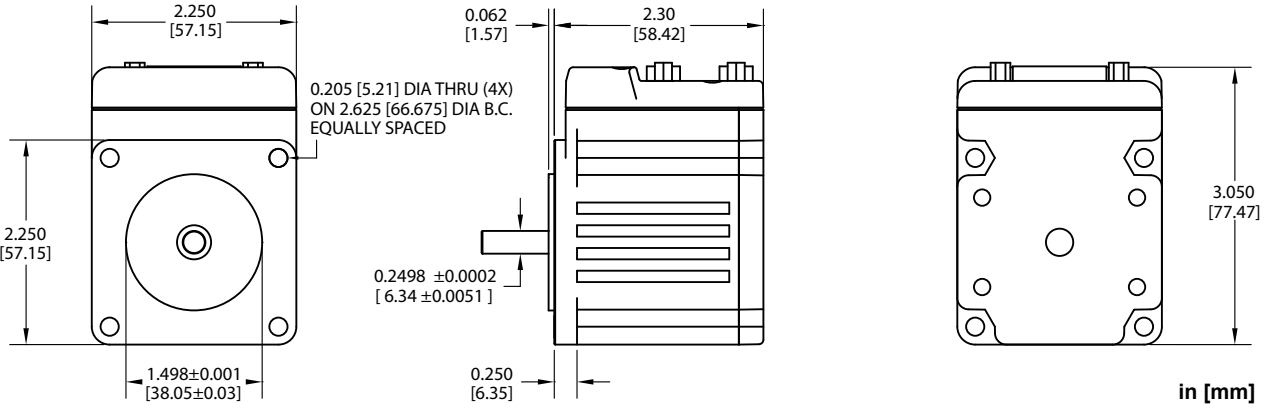

**SM232x5D-SM234x5D (No Options) CAD Drawing**

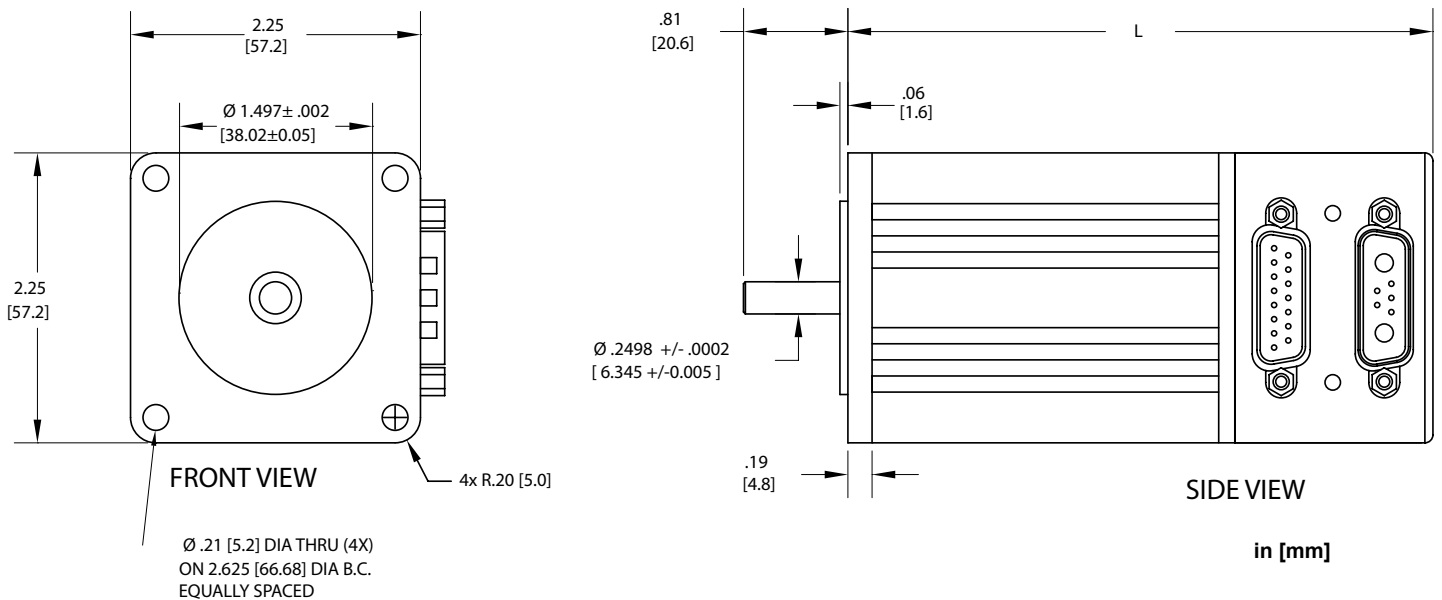

- Overview
- Software
- C5 D-Style
- C5 M-Style
- C6 M-Style
- C6 Low-Cost
- Cables, Etc.
- Actuators
- Gearheads
- Power Supplies

**SM34165D (No Options) CAD Drawing**

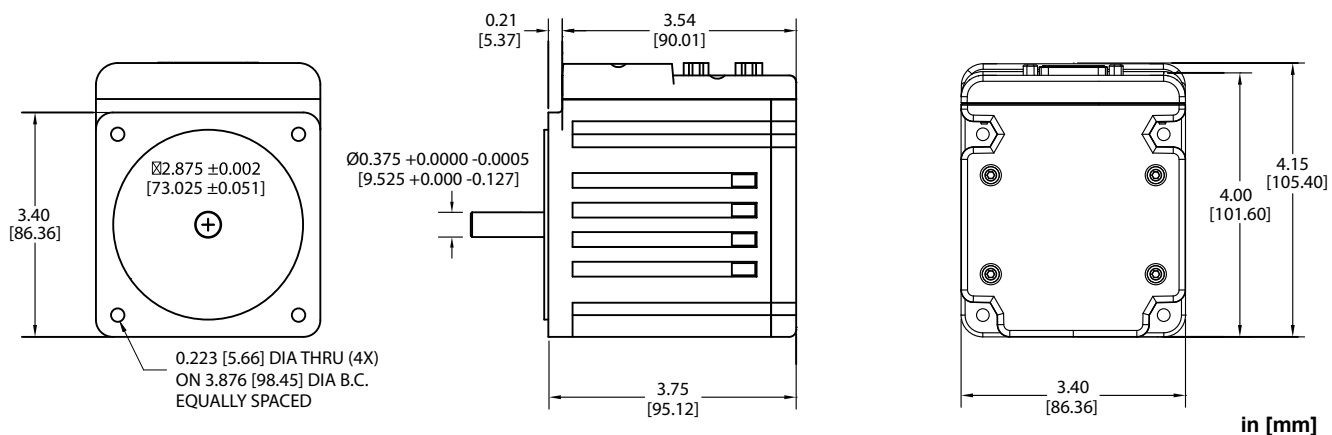

**SM34165DT (No Options) CAD Drawing**

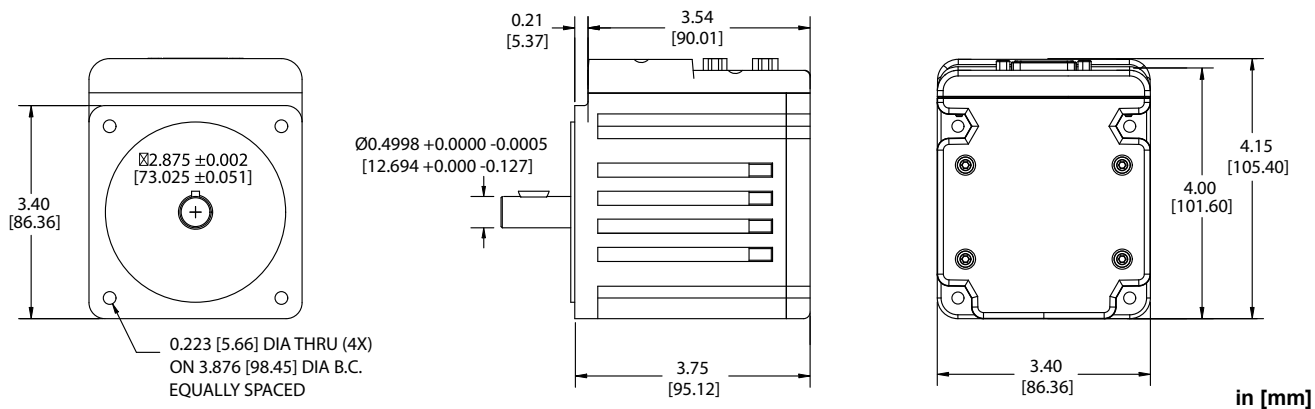

**SM34205D-SM34505D (No Options) CAD Drawing**

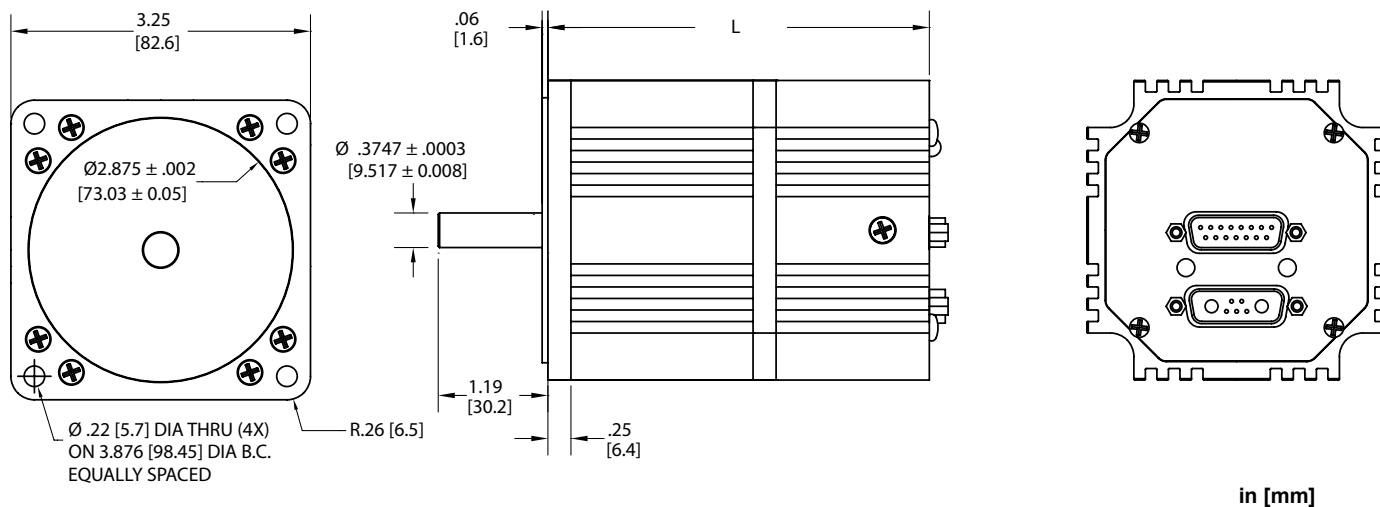

Overview

Software

C5 D-Style

C5 M-Style

C6 M-Style

C6 Low-Cost

Cables, Etc.

Actuators

Gearheads

Power Supplies

Overview

Software

C5 D-Style

C5 M-Style

C6 M-Style

C6 Low-Cost

Cables, Etc.

Actuators

Gearheads

Power Supplies

PIN	Main Power	Specifications	Notes	P1
1	I/O – 6 GP, Index Input or “G” Command For -CDS7, CAN-L only	25 mAmp Sink or Source 10 Bit 0-5 VDC A/D	Redundant Connection on I/O Connector	<p><b>7W2 Combo D-Sub Connector</b></p>
2	+5 VDC Out; For -CDS7, CAN-H only	50 mAmps Max. (Total)		
3	RS-232 Transmit	Com ch. 0	115.2 KBaud Max.	
4	RS-232 Receive	Com ch. 0	115.2 KBaud Max.	
5	Common Ground (Typ. SIG Ground)			
A1	Main Power: +20-48 VDC			
A2	Common Ground (Req'd POWER Ground)		Must be Main Power Ground	

PIN	I/O Connector (5 VTTL I/O)	Specifications	Notes	P2
1	I/O – 0 GP or Encoder A or Step Input	25 mAmp Sink or Source 10 Bit 0-5 VDC A/D	1.5 MHz Max. as Encoder or Step Input	<p><b>P2 DB-15 D-Sub Connector</b></p>
2	I/O – 1 GP or Encoder B or Direction Input	25 mAmp Sink or Source 10 Bit 0-5 VDC A/D	1.5 MHz Max. as Encoder or Direction Input	
3	I/O – 2 Positive Over Travel or GP	25 mAmp Sink or Source 10 Bit 0-5 VDC A/D		
4	I/O – 3 Negative Over Travel or GP	25 mAmp Sink or Source 10 Bit 0-5 VDC A/D		
5	I/O – 4 GP, IIC (SDA) or RS-485 A (Com ch. 1)	25 mAmp Sink or Source 10 Bit 0-5 VDC A/D	115.2 KBaud Max.	
6	I/O – 5 GP, IIC (SCL) or RS-485 B (Com ch. 1)	25 mAmp Sink or Source 10 Bit 0-5 VDC A/D	115.2 KBaud Max.	
7	I/O – 6 GP, Index Input or “G” Command	25 mAmp Sink or Source 10 Bit 0-5 VDC A/D	Redundant Connection on Main Power Connector	
8	Phase A Encoder Output			
9	Phase B Encoder Output			
10	RS-232 Transmit; For -CDS/7, CAN-L Only	Com ch. 0	115.2 KBaud Max.	
11	RS-232 Receive; For -CDS/7, CAN-H Only	Com ch. 0	115.2 KBaud Max.	
12	+5 VDC Out	50 mAmp Max. (Total)		
13	Common Ground (Typ. SIG Ground)			
14	Common Ground			
15	Main Power: +20-48 VDC	If DE Option, Control Power Separate from Main Power		

Note: I/O ports input impedance = 5 kohm (5 kohm pull-up resistor)

PIN	CAN bus	Connection	Notes	P3
1	NC	NC		<p><b>M12 5-PIN FEMALE END VIEW</b></p>
2	+V	NC Except DeviceNet	Input Current < 10 mA	
3	-V (Ground, Not Common)	CAN Ground	Isolated	
4	CAN-H	1 MBaud Max.		
5	CAN-L	1 MBaud Max.		

PIN	Isolated 24 VDC I/O Connector	Max. Load (Sourcing)	Notes	P4
1	I/O – 16 GP	150 mAmps	These I/O ports also support analog input	<p><b>M12 12-PIN FEMALE END VIEW</b></p>
2	I/O – 17 GP	150 mAmps		
3	I/O – 18 GP	150 mAmps		
4	I/O – 19 GP	150 mAmps		
5	I/O – 20 GP	300 mAmps		
6	I/O – 21 GP	300 mAmps		
7	I/O – 22 GP	300 mAmps		
8	I/O – 23 GP	300 mAmps		
9	I/O – 24 GP	300 mAmps		
10	I/O – 25 GP	300 mAmps		
11	+24 Volts Input	18-32 VDC		
12	Ground-I/O (Not Common)			

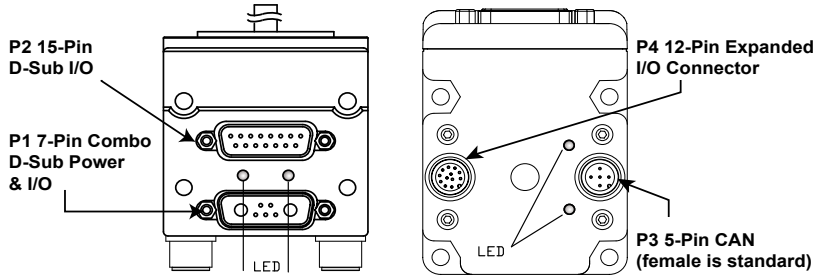

**CAUTION:** P2 DB-15 D-Sub Connector pins 14 and 15 are intended for use with DE series motors for control power only. Attempting to supply main servo-drive power to a non-DE motor through those pins will result in immediate damage to the electronics and void the warranty.

**CAUTION:** Connectors P3 and P4 must be finger tightened only! DO NOT use a tool. Doing so can cause overtightening of the connection, which may damage the connector and will void the warranty.



# CANopen

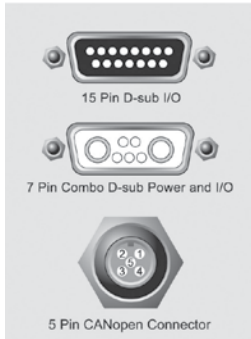

**CANopen Pinout:**

- 1 Not Connected
- 2 Not Connected
- 3 CAN ground
- 4 CAN H
- 5 CAN L

## Moog Animatics CANopen SmartMotor™

Features include:

- All basic motion commands available via CiA V4.02 specification
- Ability to read/write all SmartMotor variables
- Use of onboard I/O via CANopen gateway, SmartMotor program, or RS-232 commands
- Ability to run 1000 SmartMotor subroutines via CANopen
- Online diagnostics of the SmartMotor via SMI software and RS-232 connection
- Up to 127 nodes
- 250 microsecond interrupt-driven subroutine
- Baud rates: 20, 50, 125, 250, 500 Kbps, 1 Mbps; default 125 Kbps



**NOTE: This option DOES NOT apply to all models, refer to website or factory.**

# DeviceNet

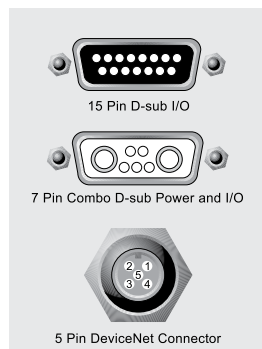

**DeviceNet Pinout:**

- 1 Not Connected
- 2 +24V
- 3 Common
- 4 CAN H
- 5 CAN L



## Moog Animatics DeviceNet SmartMotor™

Features include:

- Polled I/O and Explicit Messages from your PLC to control all SmartMotor operation
- Read/Write control over all ODVA Position Controller parameters
- Use of onboard I/O via DeviceNet, SmartMotor program or RS-232 commands
- Ability to run 1000 SmartMotor subroutines via DeviceNet and read/write four 32-bit user variables
- Online diagnostics of the SmartMotors via SMI software and RS-232 connection
- Up to 64 DeviceNet nodes
- 250 microsecond interrupt-driven subroutine
- Baud rates: 125, 250, 500 Kbps, 1 Mbps; default 125 Kbps



**NOTE: This option DOES NOT apply to all models, refer to website or factory.**

# PROFIBUS

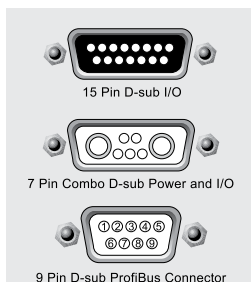

**Profibus Pinout:**

- |          |         |
|----------|---------|
| 1 NC     | 6 +5V   |
| 2 NC     | 7 NC    |
| 3 BUS-B  | 8 BUS-A |
| 4 NC     | 9 NC    |
| 5 ground |         |

## Moog Animatics PROFIBUS SmartMotor™

Features include:

- Command/Response Codes for all Class 5 SmartMotor commands
- Use of onboard I/O via PROFIBUS, SmartMotor program, or RS-232 commands
- Ability to run 1000 SmartMotor subroutines via PROFIBUS
- Ability to read/write all SmartMotor variables
- Online diagnostics of the SmartMotor via SMI software and RS-232 connection
- Up to 127 PROFIBUS nodes
- 250 microsecond interrupt-driven subroutine
- Baud rates: default 1.5 Mbps  
- 9.6, 19.2, 31.25, 45.45, 93.75, 187.5, 500 Kbps, 1.5, 3, 6, 12 Mbps



**NOTE: PROFIBUS baud rates are achievable only with proper cable length and termination connectors. The minimum cable length when operating  $\geq 1$  Mbaud is 1 meter (3 feet). If the cable is too short, reflected impedance can cause loss of communications data packets and spurious node errors.**

Overview

Software

C5 D-Style

C5 M-Style

C6 M-Style

C6 Low-Cost

Cables, Etc.

Actuators

Gearheads

Power Supplies

## CAN Bus through 7W2 Connector (CDS7 Option)

Power, CAN Bus and RS-232 communications in a simple, single-cable solution.

Once again, Moog Animatics raises the bar in servo motor design, features and ease of use with the release of its new CDS (CAN over D-Sub) option – CDS7. It lets you create a CANopen network through either the DB-15 or the 7W2 D-Sub connector on top of the motor to make room for a brake and allowing it to be used in numerous vertical axis applications. When coupled with our new CDS7 Add-A-Motor™ cable, you can make a simple, single-cable, power and communications connection from motor to motor<sup>1</sup> — no other integrated motor manufacturer offers this capability.

Unlike competitive CANopen devices, CDS7 features RS-232 auto-detection from SMI™ for easy setup and CAN network addressing. With CDS7, there is no need to individually address each motor in the CAN network on startup — SMI™ can detect and auto-address every SmartMotor™ in the system with just one line of code.<sup>2</sup>

Additionally, the new CDS7 option provides:

- A foolproof Pass-Thru Terminator (shunt) easily installed on the DB-15 connector of the last motor
- A compact design that decreases the required space in the machine
- Full backward compatibility with the previous CDS option, allowing CDS7 motors to be used in new or old systems<sup>3</sup>

Finally, by adding CDS7 to your SmartMotor™, you gain access to these proprietary SmartMotor™ features:

- Combitronic™ technology for simplified motor-to-motor communications
- I/O Device CAN Bus Mastering for simple, economical and effective total machine control with just the SmartMotor™

The CDS7 option is fully compatible with all Class 5 D-style SmartMotors. Consult the factory for a complete list of compatible part numbers.

<sup>1</sup> Proper termination is required at both ends of the bus. For details, see the Class 5 SmartMotor™ installation and CANopen guides.

<sup>2</sup> Requires CDS7 SmartMotors and CDS7 Add-A-Motor cables or equivalent customer-supplied cables.

<sup>3</sup> CDS7 Add-A-Motor cables are not compatible with the older –CDS motors. If a CDS7 motor is being used in an older CDS system, it must be wired like the other –CDS motors in that system. See the Class 5 SmartMotor™ installation and CANopen guides.

**⚠ WARNING: Proper bus biasing and termination must be incorporated into system wiring to ensure quality communications over any industrial bus. Failure to do so could result in loss of communications. Please consult the associated bus standard organizations for details.**

## Recommended “DE” Option

The DE option allows the controller and drive-amplifier to be powered from separate 24-48 VDC power supplies.

- Controller can be powered from a standard 24 VDC supply
- Position will not be lost if drive power is lost
- No need to re-home
- Load surges will not cause power surge on controller
- Standard battery options are made simpler

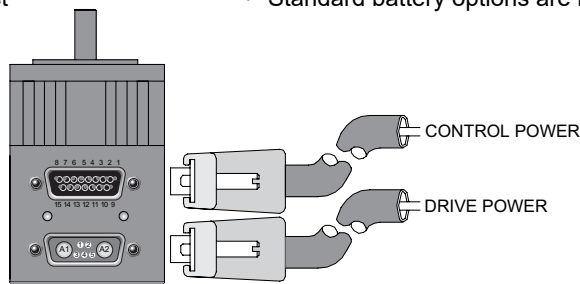

Please see the *SmartMotor Installation & Startup Guide* for the schematic diagram and installation details.

### NOTE:

- The same power supply may be used for control and drive power, but maximum protection is provided with separate power supplies.
- Only DE option SmartMotors can be wired in this manner. Attempting to power a non-DE motor in this way will damage the motor and void the warranty.
- To suppress back EMF, shunts should be placed between the E-stop switch and motor Drive Power input.
- All M-style SmartMotors are designed to always have separate drive and control power. As a result, no DE designation is available for those motors.

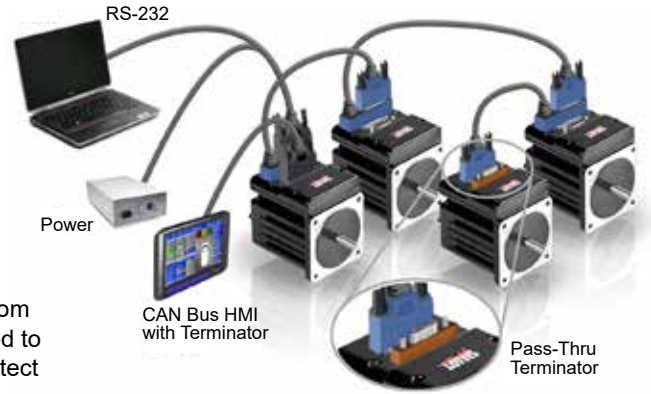

Moog Animatics' Class 5 SmartMotor™ with M-style connectors offers optional IP65 and IP67 ratings for NEMA 23 and 34 frame sizes. This series of harsh-environment rated M-style SmartMotor combines the quality and advanced motion control capabilities of the integrated servo in combination with an IP rating.

SmartMotors with the IP65 rating are both completely dust tight and protected from ingress of liquid that may occur from any angle, rendering no harmful effects on the electrical enclosure. SmartMotors with the IP67 rating can be submersed in water or other non-hazardous liquids to a depth of one meter for a maximum time of 30 minutes. Therefore, conditions with high levels of humidity and condensation are no longer a problem. The IP-rated models provide the perfect integrated servo for food and beverage manufacturing and packaging, rugged outdoor conditions, as well as any wet environment.



**Class 5 M-Style SmartMotor Features**

- Complete barrier against dust and other harmful particles
- Splash and submersion protected for wet environments with the IP options\*
- Industrial style connectors for ensured communication
- New industry capabilities such as food and beverage manufacturing and packaging, demanding outdoor conditions, and nautical machinery

*\*IP rating depends on motor options.*

For more information about the M-style SmartMotor, applications or to read the white paper "Integrated Solutions for Harsh Environments", visit [www.animatics.com](http://www.animatics.com).

**Understanding M-Style SmartMotor Part Numbers**

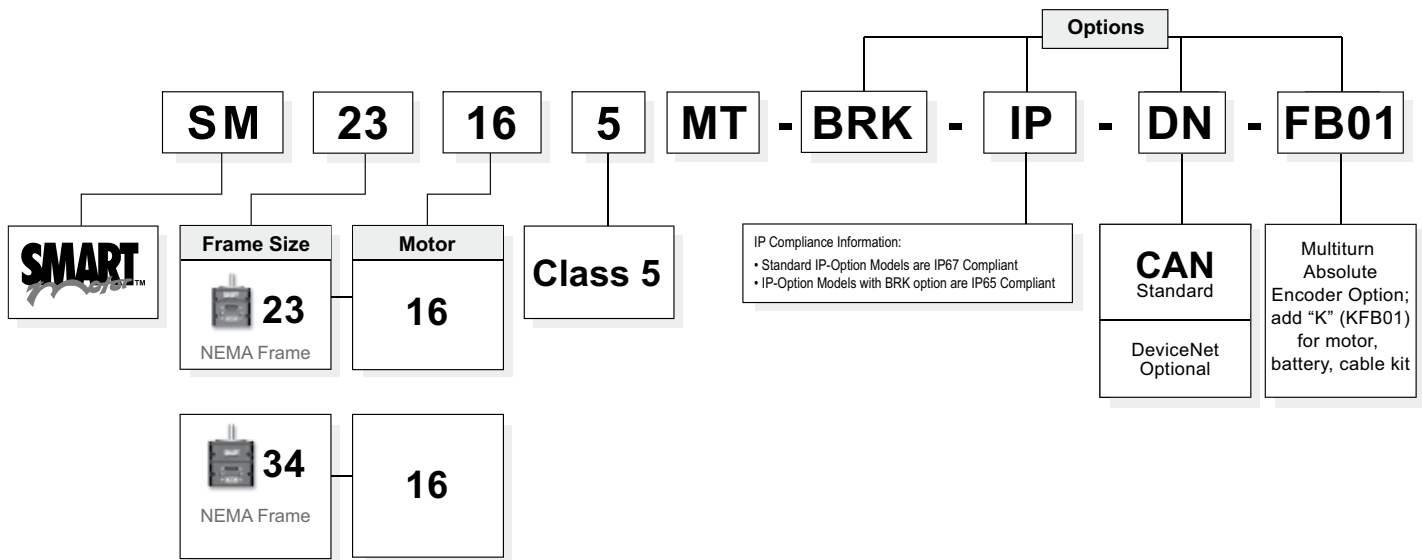

**Standard on all M-Style SmartMotors: - C, - AD1 and - DE**

Though the above items are "options" on the D-Style SmartMotor, they have been incorporated as standard for the M-Style SmartMotors.

For options such as - F1, - F2, - K, - SL and - SH, please contact Moog Animatics at (650) 960-4216 or email [animatics\\_sales@moog.com](mailto:animatics_sales@moog.com).

**NOTE: DMX protocol is standard on all Class 5 SmartMotors.**



- All M-style SmartMotors have a primary RS-485 communications port
- All M-style SmartMotors have 11 channels general purpose 24V isolated I/O
- Dedicated Drive Enable In and NOT-FAULT Out
- Dedicated encoder bus
- IP65/IP67 available (depends on other options)  
*IP rating may affect performance - consult factory for details.*

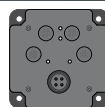

Back View

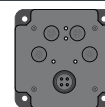

Back View

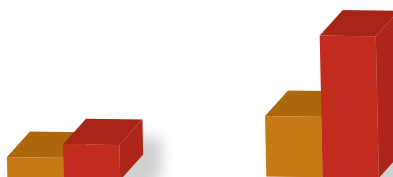

		SM23165MT	SM34165MT
<b>Continuous Torque @48V</b>	in-lb	4.25	12.58
	oz-in	68	201
<b>Peak Torque</b>	N-m	0.48	1.42
	in-lb	9.45	34.88
	oz-in	151	558
	N-m	1.07	3.94
<b>Nominal Continuous Power</b>	Watts	189	472
<b>No Load Speed</b>	RPM	5,000	4,900
<b>Max. Continuous Current</b>	RPM	3,700	4,500
	Amps	6.4	13
<b>Peak Power</b>	RPM	2,800	3,300
	Watts	255	1120
<b>Voltage Constant</b>	V/krpm	9.6	9.8
<b>Inductance</b>	mH	2.01	0.315
<b>Encoder Resolution</b>	Counts/Rev	4,000	8,000
<b>Rotor Inertia</b>	oz-in-sec <sup>2</sup>	0.001	0.0142
	10 <sup>-5</sup> kg-m <sup>2</sup>	0.706	10.031
<b>Weight</b>	lb	1.5	6.0
	kg	0.68	2.72
<b>Shaft Diameter</b>	in	0.375	0.500
	mm	9.53	12.70
<b>Shaft, Radial Load</b>	lb	15	30
	kg	6.80	13.61
<b>Shaft, Axial Thrust Load</b>	lb	3	3
	kg	1.36	1.36
<b>DeviceNet Option</b>		Firmware Option	Firmware Option
<b>PROFIBUS Option</b>			
<b>CANopen Option</b>		Standard	Standard

Due to the variety of operating conditions and applications for Moog Animatics' products, the end user is solely responsible for making the final selection of the Moog Animatics products and systems based on their own analysis and testing, and ensuring that all performance, safety and warning requirements for the application and product are met. Please consult factory for any supporting hardware and cables needed, full details and latest information.



**SM23165MT**

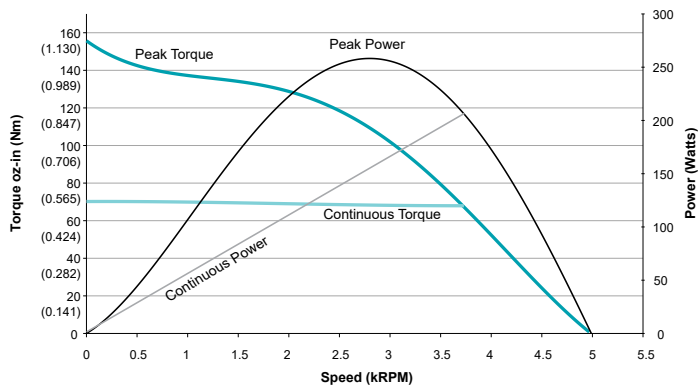

**SM34165MT**

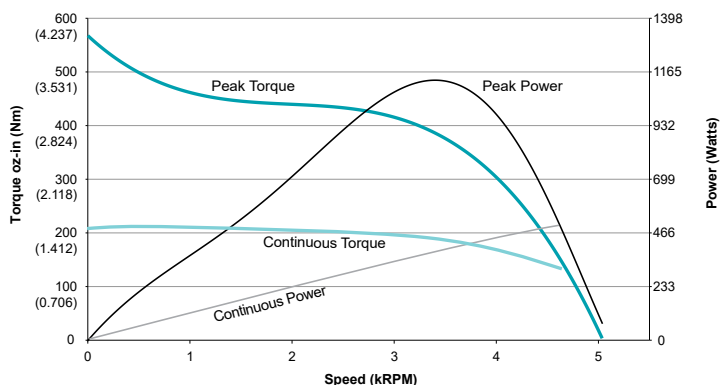

**SmartMotor SM23165MT (No Options) CAD Drawing**

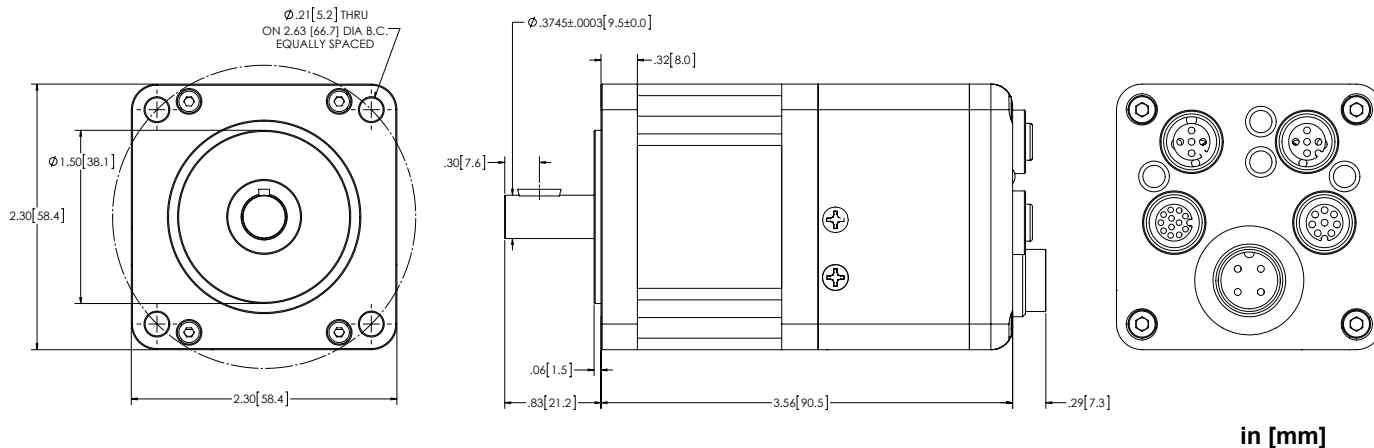

**SmartMotor SM34165MT (No Options) CAD Drawing**

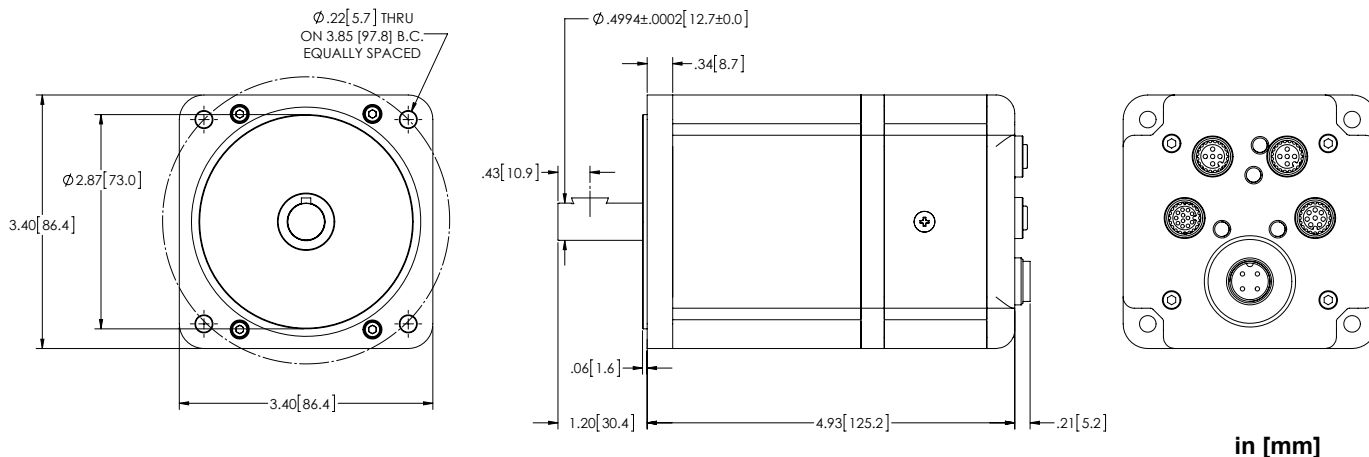

All torque curves based on 48 VDC at 25°C ambient with rise to 85°C.  
 Motors were operated using MDE (Enhanced Drive Mode) Commutation.  
 For ambient temperatures above 25°C, continuous torque must be linearly derated to 0% at 85°C.  
 Operating temperature range: 0°C – 85°C.  
 Storage temperature range: -10°C – 85°C, noncondensing.

Overview

PIN	Main Power	Specifications	Notes	P1
1	Control Power In	+12.5V Min., 32V Max.	Also Supplies I/O	
2	Chassis Ground	Chassis Ground Only	Not Connected to Common	
3	Control, Com, I/O and Amplifier Ground	Common Ground (Req'd. Ground)	Nonisolated	
4	Amplifier Power In	+12.5V Min., 48V Max.	Powers Amplifier Only	

Software

PIN	Communications Connector	Specifications	Notes	P2
1	Control, Com, I/O and Amp Ground	Common Ground	Nonisolated	
2	RS-485 B, Com ch. 0	115.2 KBAud Max.		
3	RS-485 A, Com ch. 0	115.2 KBAud Max.		
4	Encoder A+ Input/Output	1.5 MHz Max. as Encoder or Step Input	Configurable as Encoder Output	
5	Encoder B- Input/Output	1.5 MHz Max. as Encoder or Direction Input	Configurable as Encoder Output	
6	Encoder A- Input/Output	1.5 MHz Max. as Encoder or Step Input	Configurable as Encoder Output	
7	+5V Out	250 mA Max.		
8	Encoder B+ Input/Output	1.5 MHz Max. as Encoder or Direction Input	Configurable as Encoder Output	

C5 D-Style

PIN	24V I/O Connector	Specifications	Notes	P3
1	I/O – 0 GP	150 mAmps Max.	These I/O ports also support analog input	
2	I/O – 1 GP	150 mAmps Max.		
3	I/O – 4 GP	150 mAmps Max.		
4	I/O – 5 GP or Index	150 mAmps Max.		
5	I/O – 6 GP or "G" Command	150 mAmps Max.		
6	I/O – 7 GP	150 mAmps Max.		
7	I/O – 8 GP or Brake Line Output	300 mAmps Max.		
8	I/O – 9 GP	300 mAmps Max.		
9	Not Fault Out	150 mAmps Max.		
10	Drive Enable Input	150 mAmps Max.		
11	+24 Volts Out	12.5 V Min., 28 V Max.		
12	Ground Common	Common Ground		

C5 M-Style

C6 M-Style

Note: I/O ports input impedance > 10 kohm

PIN	24V I/O Connector	Specifications	Notes	P4
1	+24 Volts Out		From Control Pwr In	
2	I/O – 3 GP -Limit	150 mAmps Max.	Configurable; supports analog in	
3	Ground	Common Ground	Nonisolated	
4	I/O – 2 GP +Limit	150 mAmps Max.	Configurable; supports analog in	
5	I/O – 10 GP	150 mAmps Max.	Configurable; supports analog in	

C6 Low-Cost

Note: I/O ports input impedance > 10 kohm

PIN	CAN Connector	Specifications	Notes	P5
1	NC	NC		
2	+V	NC Except DeviceNet	Input Current < 10 mA	
3	-V (Ground)	Common Ground	Nonisolated	
4	CAN-H	1 Mbaud Max.		
5	CAN-L	1 Mbaud Max.		

Cables, Etc.

Actuators

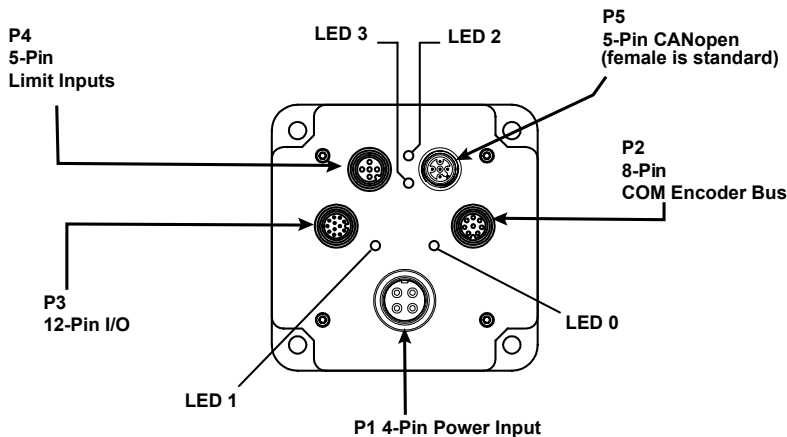

**CAUTION:** Exceeding 32 VDC into control power on any of the +24V pins may cause immediate damage to the internal electronics. Exceeding a sustained voltage of 48V to pin 4 of the P1 Power Input may cause immediate damage to the internal electronics. Exceeding these voltage limits will void the warranty.

**CAUTION:** M-style connectors must be finger tightened only! DO NOT use a tool. Doing so can cause overtightening of the connection, which may damage the connector and will void the warranty.

The Class 6 Industrial Ethernet SmartMotor™, which is available in both standard servo (shown) and hybrid servo versions, represents the next step in the evolution of the SmartMotor integrated motor design. The Class 6 motor lineup includes EtherCAT® (EEC option), PROFINET® (EPN option), and EtherNet/IP™ (EIP option) versions.

These motors are designed for maximum performance and connectivity. They incorporate a high-end, high-speed processor for exceptional performance, data update rates are as fast as 1 millisecond. There are dual industrial Ethernet ports onboard (no hub or switch required), as well as connections for RS-485 and USB. Additionally, they provide plenty of I/O, with the option to add more through an external expander, for easy integration into any system.

**Key Features and Benefits**

- Simplify wiring, reduce cost through the onboard dual-port Ethernet switch
- Optionally program, configure and get live diagnostics through the USB interface
- Optionally communicate with the motor through the RS-485 half-duplex port, which provides access as a Modbus Remote Terminal Unit (RTU) Slave
- Easily access SmartMotor programmable autonomous control features in slave mode, which allows special user-programmed functions
  - Reduce limit switch wiring and PLC programming through adaptable distributed control
  - Accurately capture position for high-speed registration applications
  - Quickly reduce costs and improve reliability through use of programmable homing and limits
  - Precisely define motion profiles with local cam execution
  - Easy configuration and status monitoring of Industrial Ethernet and field buses
- Actively monitor/troubleshoot each motor through local error reporting and diagnostic codes
- Local/standalone benefits (see manual for details):
  - Simplify programming and calculate 32-bit precision motion parameters on the fly with floating-point math and trigonometric functions
  - Govern a move by running it on top of a gearing or camming relationship using the dual trajectory generators
  - Create precise spooling/winding shapes and control tension through advanced gearing (supports preset traverse/take-up parameters)
  - Create complex patterns through advanced camming (with cubic spline interpolation and dynamic frequency/amplitude)
  - Highly configurable local I/O for motion control and general-purpose use in user programs:
    - Drive enable input, fault output, travel limits, registration and position capture
    - External encoder input supporting A-quad-B or Step-and-Direction
    - Total of 7 configurable inputs
    - High-current outputs with external brake-control function



**Class 6 EtherCAT® (EEC option) Fieldbus**  
 Industry standard CiA 402 motion profile supports:

- PP, PV, HM, TQ, CSP, CSV, and CST modes
- Dynamic mapping of process data objects (cyclic data exchanges)
- Real time coordinated control using Distributed Clock (DC)



**Class 6 PROFINET® (EPN option) Fieldbus**

- PROFINET RTC - Real Time Cyclic transfers
- Class 1 and 2 (certified) - unsynchronized
- Class 3 (certification pending) - synchronized SmartMotor clocks
- PROFINET RTA – Real Time Acyclic protocol
- DCP, LLDP, SNMP, MIB-II, and LLDP MIB support



**Class 6 EtherNet/IP™ (EIP option) Fieldbus**  
 Easily integrates as a position controller (10 h) device, for:

- Access to unique SmartMotor commands and parameters
- Improved uptime with optional redundant cabling through Device Level Ring (DLR)
- Optimal performance ensured through Quality of Service (QoS)
- Simplified, modular programming through Add On Instructions (AOI)
- Direct access to SmartMotor native commands and parameters through TCP/IP

**Advanced Class 6 M-Style Part Numbering**

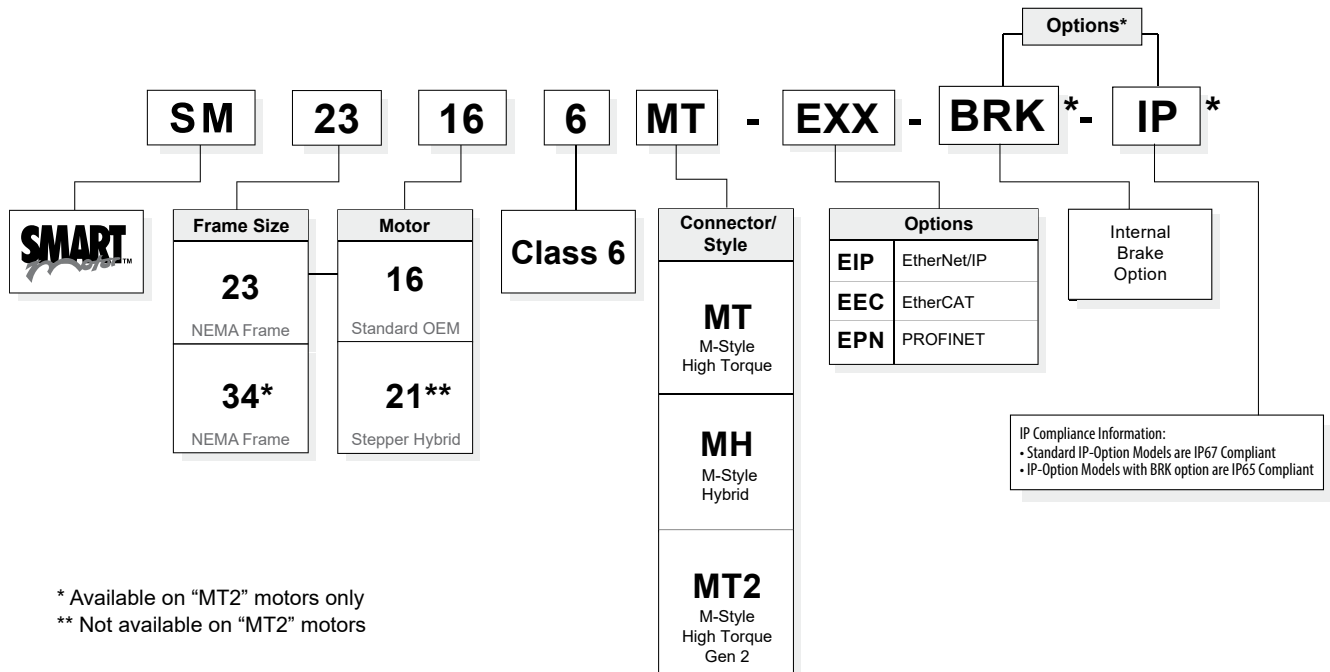

Overview

Software

C5 D-Style

C5 M-Style

C6 M-Style

C6 Low-Cost

Cables, Etc.

Actuators

Gearheads

Power Supplies

SmartMotor™ Series	SM23166MT-EXX	
Continuous Torque at 48 volts	68	oz-in
	0.48	N-m
Peak Torque	128	oz-in
	0.90	N-m
Nominal Continuous Power	189	watts
Nominal Peak Power	213	watts
No Load Speed	4,700	rpm
Voltage Constant	9.08	V/kRPM
Winding Resistance	0.7	Ohms
Encoder Resolution	4,000	counts/rev
Rotor Inertia	0.00103	oz-in-sec <sup>2</sup>
	7.27	10 <sup>-6</sup> kg-m <sup>2</sup>
Weight	1.7	lb
	0.77	kg
Shaft Diameter	.375	in
	9.53	mm
Shaft, Radial Load	15.0	lb
	6.80	kg
Shaft, Axial Thrust Load	3.00	lb
	1.36	kg
EtherCAT Available*	Yes	
PROFINET Available*	Yes	
EtherNet/IP Available*	Yes	

### SM23166MT-EXX



Maximum temperature: 85°C at electronics, 130°C at windings.  
 Recommended ambient temperature range: 0°C – 50°C.  
 Storage temperature range: -10°C – 85°C.  
 Relative humidity: maximum 90%, noncondensing.

SmartMotor™ Series	SM23216MH-EXX	
Continuous Torque at 48 volts	165	oz-in
	1.17	N-m
Peak Torque	300	oz-in
	2.12	N-m
Nominal Continuous Power	60	watts
Nominal Peak Power	115	watts
No Load Speed	2,250	rpm
Encoder Resolution	4,000	counts/rev
Rotor Inertia	0.0065	oz-in-sec <sup>2</sup>
	4.59	10 <sup>-5</sup> kg-m <sup>2</sup>
Weight	2.79	lb
	1.27	kg
Shaft Diameter	.375	in
	9.53	mm
Shaft, Radial Load	16.86	lb
	7.65	kg
Shaft, Axial Thrust Load	3.37	lb
	1.53	kg
EtherCAT Available*	Yes	
PROFINET Available*	Yes	
EtherNet/IP Available*	Yes	

### SM23216MH-EXX



Maximum temperature: 85°C at electronics, 130°C at windings.  
 Recommended ambient temperature range: 0°C – 50°C.  
 Storage temperature range: -10°C – 85°C.  
 Relative humidity: maximum 90%, noncondensing.

For other data, please consult the factory.

\*EtherCAT® (EEC option), PROFINET® (EPN option), and EtherNet/IP™ (EIP option)

### SM23166MT-EXX Torque Curves

SM23166MT-EXX motor Torque vs. Speed, 48 volts, MDE commutation, 25°C ambient (curves are derated at higher ambient)

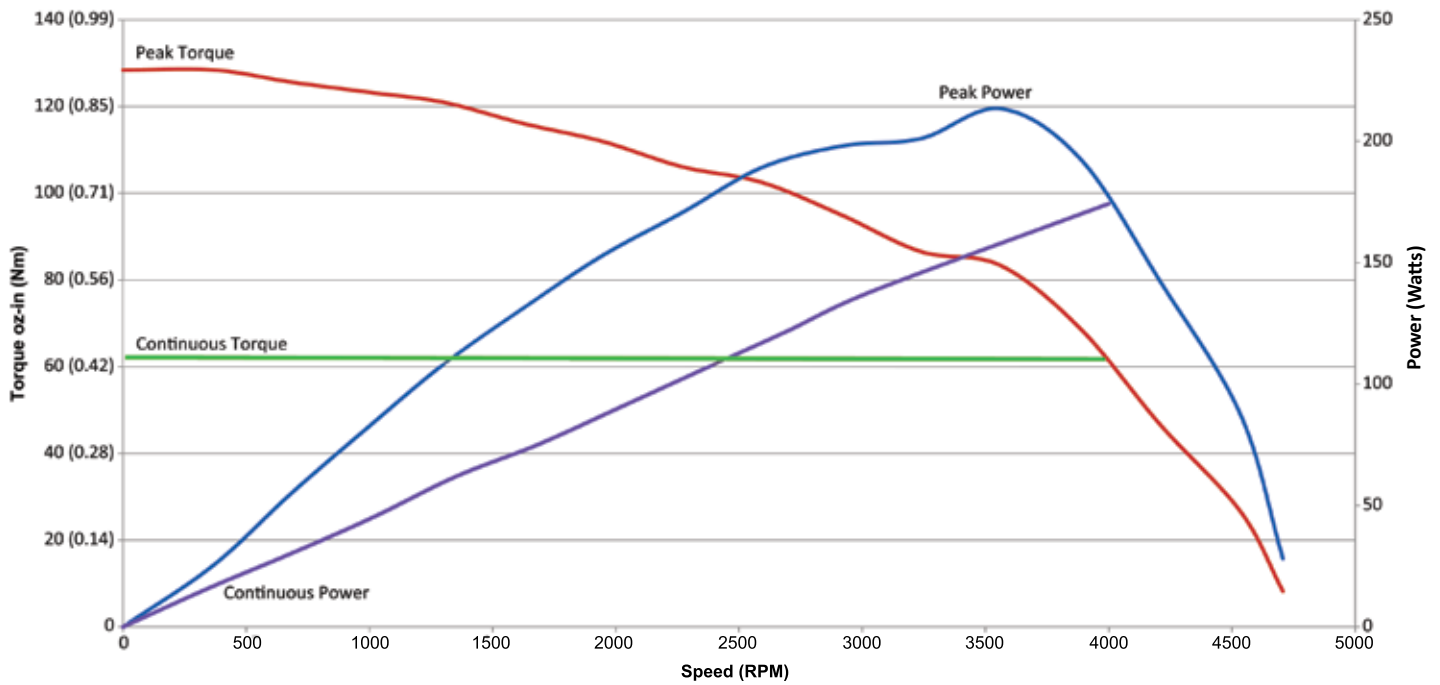

Continuous rating based on 25°C ambient temperature, motor mounted to a 6x6x¼ inch aluminum heat sink, and electronics/windings below maximum temperature. Peak torque is available for 3 seconds at a 10% duty cycle.

### SM23216MH-EXX Torque Curves

SM23216MH-EXX motor Torque vs. Speed, 48 volts, MDC commutation, 25°C ambient (curves are derated at higher ambient)

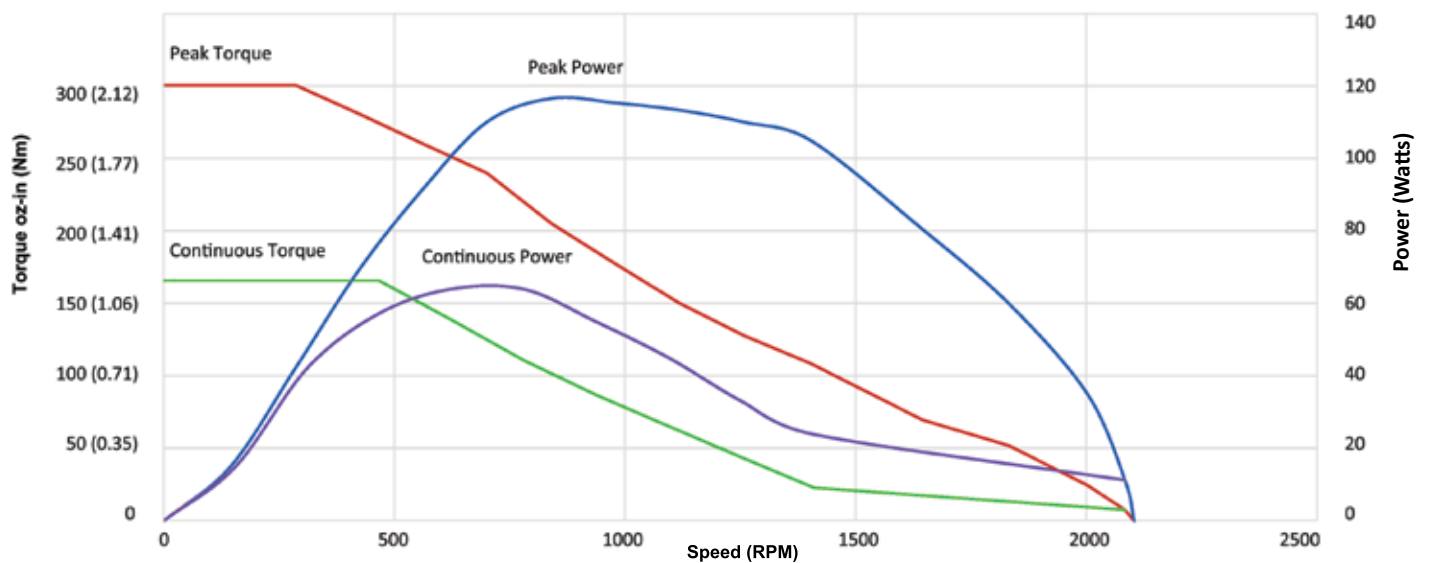

Continuous rating based on 25°C ambient temperature, motor mounted to a 6x6x¼ inch aluminum heat sink, and electronics/windings below maximum temperature. Peak torque is available for 3 seconds at a 10% duty cycle.



**SM23166MT-EXX**

NOTES:

1. INTERPRET DRAWING PER ASME Y14.100 AND ASME Y14.5.
2. KESEAT SHOWN IS ANSI 303 PER ANSI B17.2-1967, R1978

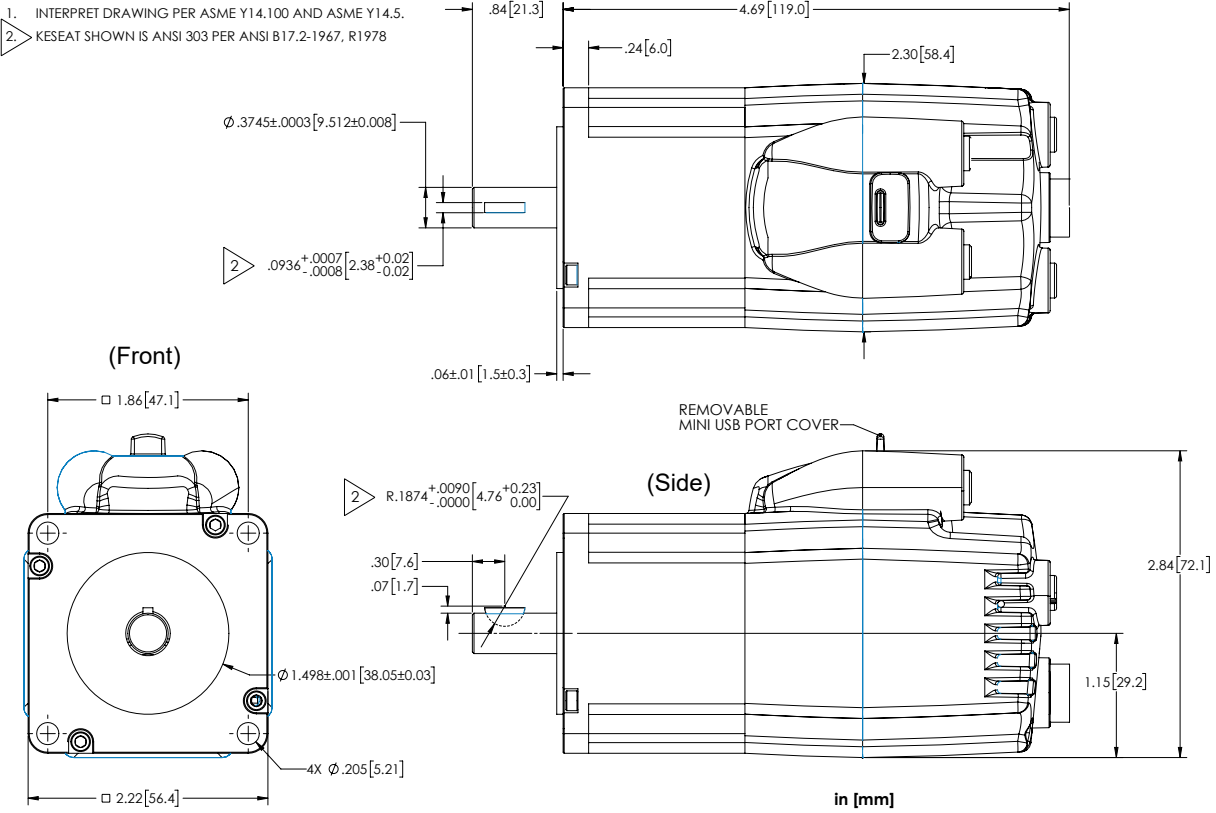

**SM23216MH-EXX**

NOTES:

1. INTERPRET DRAWING PER ASME Y14.100 AND ASME Y14.5.

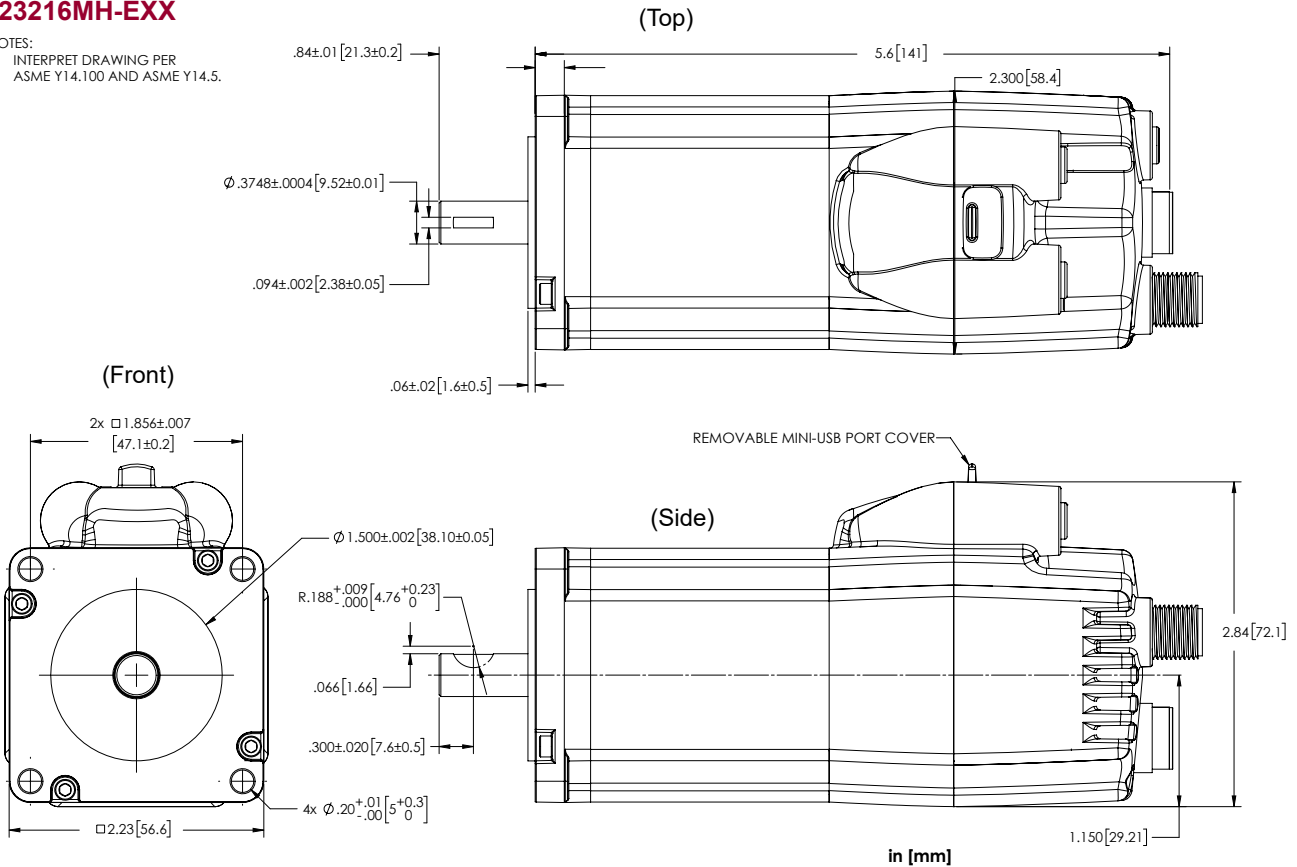

Overview

Software

C5 D-Style

C5 M-Style

C6 M-Style

C6 Low-Cost

Cables, Etc.

Actuators

Gearheads

Power Supplies

**Class 6 M-Style Connector Pinouts**

The following table shows the pinouts for the connectors on the Class 6 M-style SmartMotors.

PIN	Main Power	Specifications	Notes	P1	
1	Control Power In	+24V (±20%), 32V Max.	Also Supplies I/O		
2	Chassis Ground	Chassis Ground Only	Not Connected to Common		
3	Control, Com, I/O and Amplifier Ground	Common Ground (Req'd. Ground)	Nonisolated		
4	Amplifier Power In	+24V Min., 48V Max.	Powers Amplifier Only		
PIN	Communications Connector	Specifications	Notes	P2	
1	Control, Com, I/O and Amp Ground	Common Ground	Nonisolated		
2	RS-485 B, Com ch. 0	115.2 KBAud Max.			
3	RS-485 A, Com ch. 0	115.2 KBAud Max.			
4	Encoder A+ Input/Output	125 KHz Individual Line Frequency	Configurable as Encoder Output		
5	Encoder B- Input/Output	125 KHz Individual Line Frequency	Configurable as Encoder Output		
6	Encoder A- Input/Output	125 KHz Individual Line Frequency	Configurable as Encoder Output		
7	+5V Out	50 mA Max.			
8	Encoder B+ Input/Output	125 KHz Individual Line Frequency	Configurable as Encoder Output		
PIN	24V I/O Connector	Specifications	Notes	P3	
1	IN0 GP, Discrete or Analog Input	Inp Impedance > 10 kohm	<b>For Inputs:</b> 7 Configurable Inputs Low Lvl Thld: 3.6V Max. High Lvl Thld: 5.0V Min. Inp Hysteresis: 1.0V Min. Analog Input Scale: 10V FS		
2	IN1 GP, Discrete or Analog Input	Inp Impedance > 10 kohm			
3	IN2 Pos Limit or GP	Inp Impedance > 10 kohm			
4	IN3 Neg Limit or GP	Inp Impedance > 10 kohm			
5	IN4 GP or Ext. Enc. Index Capture	Inp Impedance > 10 kohm			
6	IN5 GP or Int. Enc. Index Capture	Inp Impedance > 10 kohm			
7	IN6 GP, G Cmd, or Homing Inp (EtherCAT)	Inp Impedance > 10 kohm			
8	IN7 Drive Enable	Inp Impedance > 10 kohm			
9	OUT8 Brake or GP	250 mAmps Max.			<b>For Outputs:</b> Do Not Exceed 500 mAmps Combined
10	OUT9 NOT FAULT	250 mAmps Max.			
11	+24 VDC Out (Supplied from P1, Pin 1)	12.5V Min., 23V Max. Load 2 Amps Max.			
12	Ground Common	Common Ground	Nonisolated		
PIN	Industrial Ethernet Connectors		Specifications	Notes	P4
	EtherNet/IP, EtherCAT	PROFINET	10/100BASE-T	Shield tied to motor housing	
1	+TX	+TD	EtherCAT=100BASE-TX	EtherCAT=Input(L), Output(R)	
2	+RX	+RD			
3	-TX	-TD			
4	-RX	-RD			

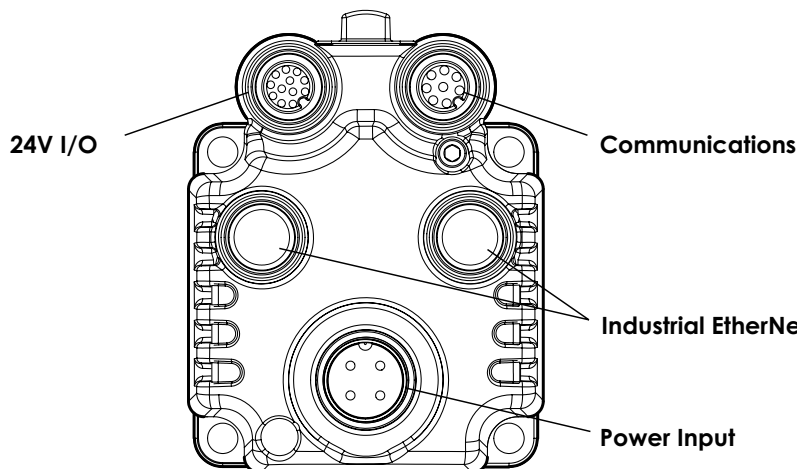

**CAUTION:** Exceeding 32 VDC into control power on any of the +24V pins may cause immediate damage to the internal electronics. Exceeding a sustained voltage of 48V to pin 4 of the P1 Power Input may cause immediate damage to the internal electronics. Exceeding these voltage limits will void the warranty.

**SmartMotor Class 5 D-Style Cables and Accessories**

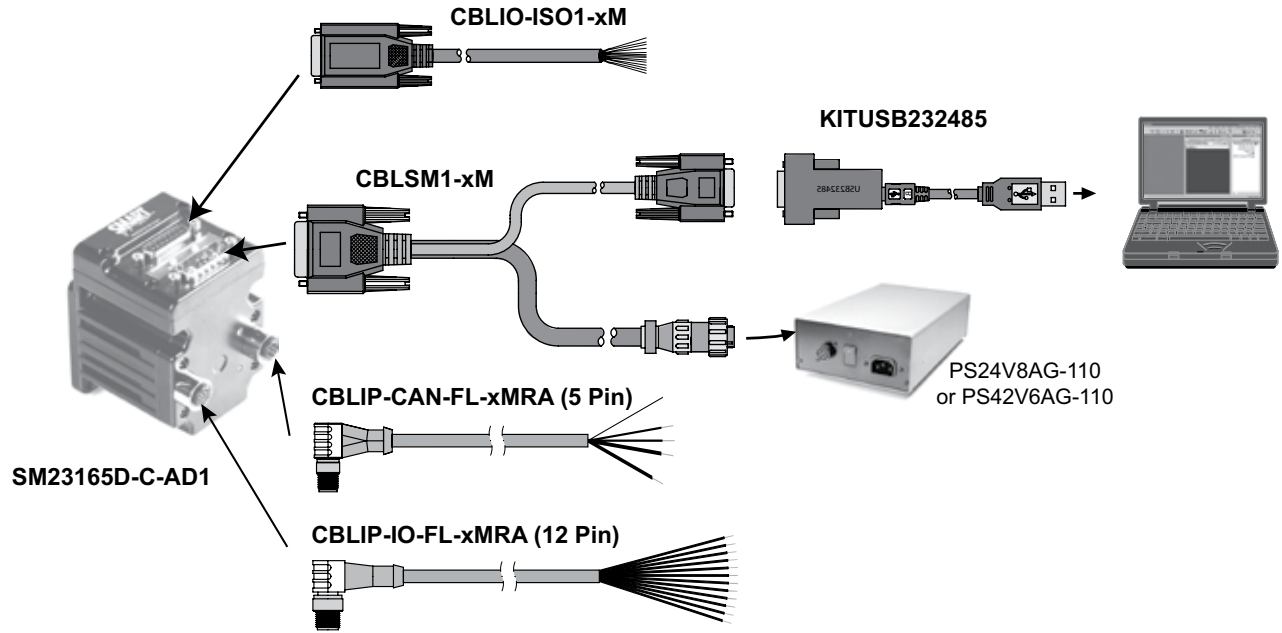

**SmartMotor Class 5 D-Style RS-232 Multidrop using Add-A-Motor Cable**

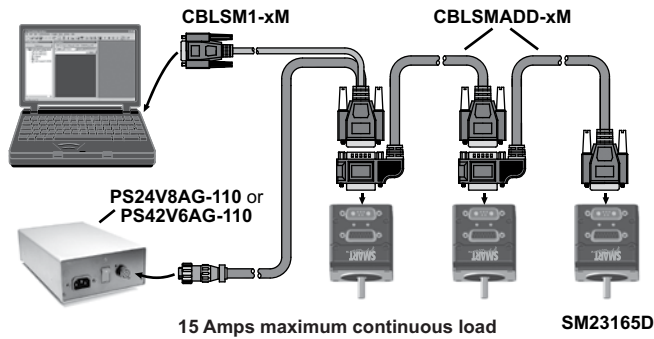

**SmartMotor Class 5 D-Style CAN Bus Multidrop using CAN Bus Y Cables**

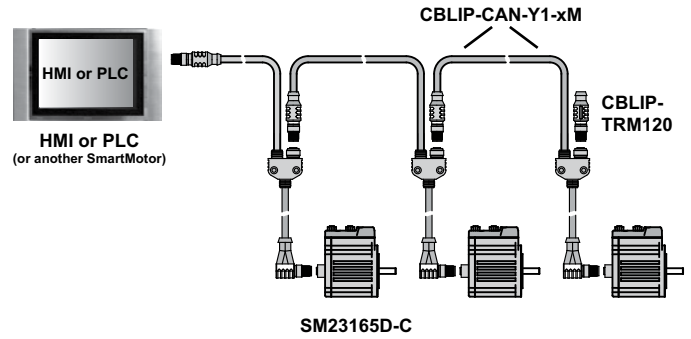

**SmartMotor Class 5 M-Style Cables and Accessories**

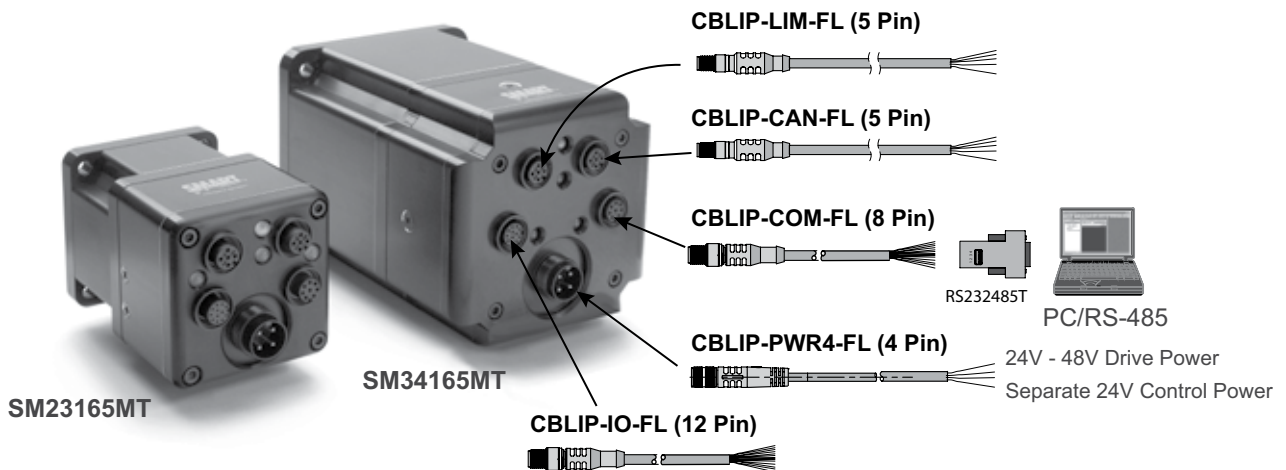

Refer to the website/factory for drawings, schematics and specifications.

### SmartMotor Class 5 M-Style

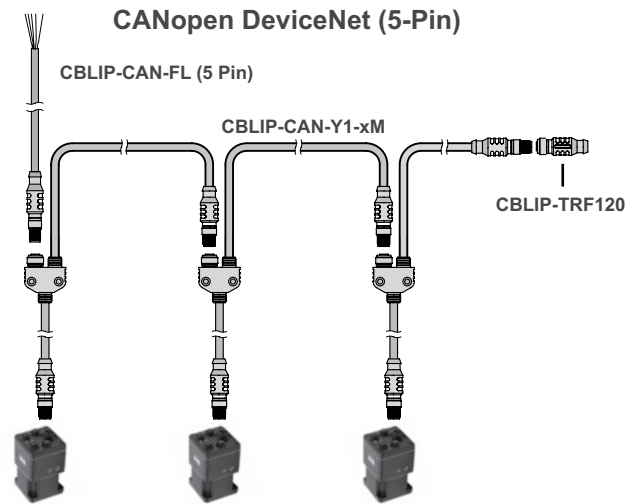
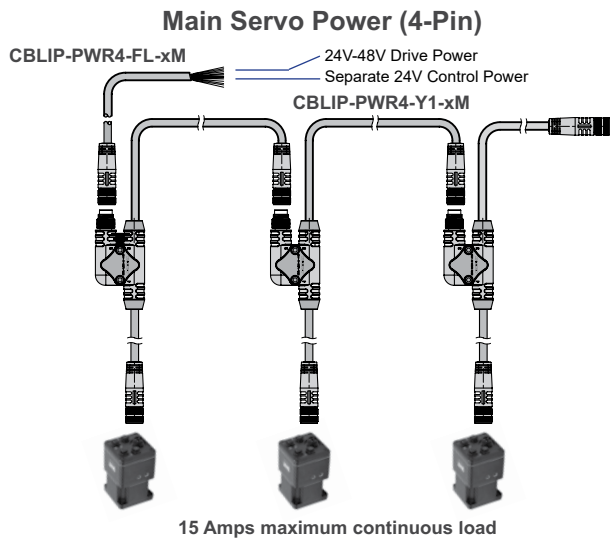

### SmartMotor Class 6 Power and I/O Multidrop

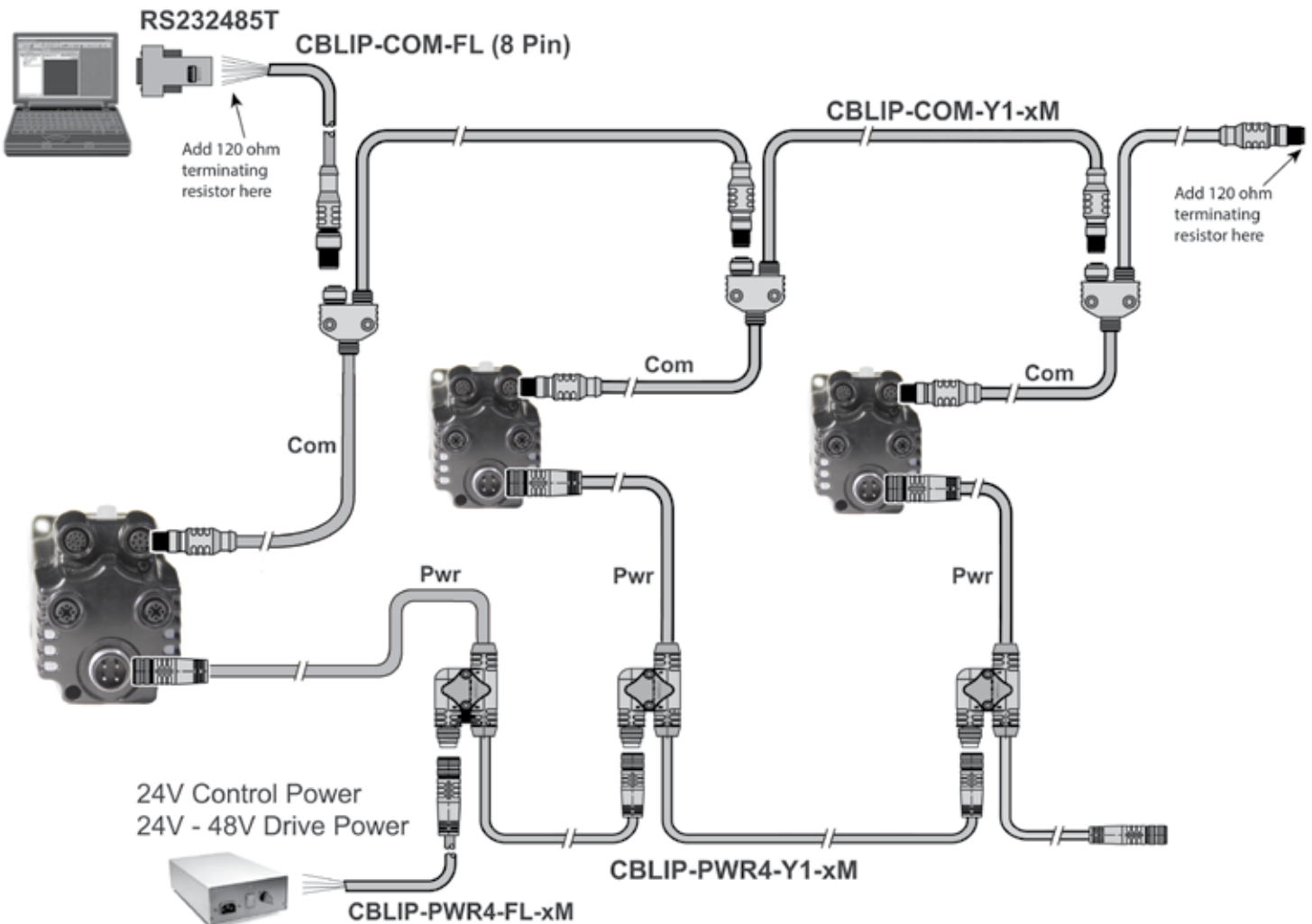

Refer to the website/factory for drawings, schematics and specifications.

Overview

Software

C5 D-Style

C5 M-Style

C6 M-Style

C6 Low-Cost

Cables, Etc.

Actuators

Gearheads

Power Supplies

**DINIO7 – Motor I/O Connector Breakout Board**

Easily interface with popular input/output blocks like those produced by Gordos, Grayhill, OPTO-22™ and other manufacturers.

The DINIO7 has slots for seven industry standard OPTO Modules and can be used with either input or output modules. The DINIO7 has a 9-pin connector for direct connection to a personal computer serial RS-232 communications port and an AniLink™ network connector. It is also equipped with an expansion bus to allow it to interface with other Moog Animatics DIN rail mount adapters.

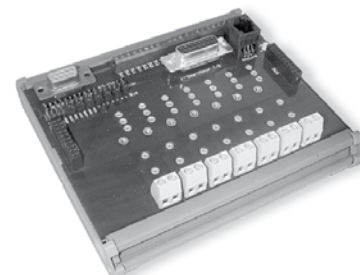

**OPTO2 – 16 Channel Opto-isolator Board**

Optically isolates and converts signals between 5 VTTL logic and 24 VDC Control Logic Systems.

- 8 input channels
- 8 output channels
- Red fail-safe LED Indications
- Plug-in connectors
- DIN rail mount
- Only 0.84 inches of rail space
- Shunt diode protection for Inductive loads



**SmartBox – Handheld Diagnostics and Testing Interface**

The SmartBox is designed as a test and development aid for SmartMotor applications. Although it is small and compact, it offers big returns in convenience and time savings. Its portability and simple operation make it ideal for use at remote locations to run SmartMotor functions and perform onsite testing.

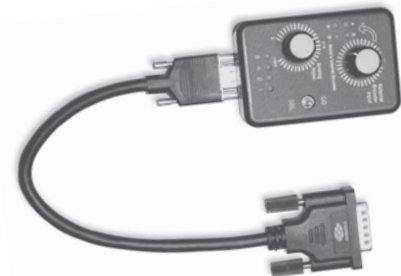

**SmartBox BCD – Handheld Diagnostics and Testing Interface for PLC Handshake Simulation**

SmartBox BCD™ is designed for use with SmartSelect™ Software. This handheld diagnostics and test interface is similar to the standard SmartBox, but is geared towards PLC I/O handshake simulation. It provides simulation of 5 inputs from a PLC and 2 outputs back to the PLC to aid in development of applications where only on/off I/O triggering is used to control the SmartMotor.



Refer to the website/factory for drawings, schematics and specifications.



All Moog Animatics Linear Integrated Systems couple proven Integrated Servo Controls with innovative designs in linear actuators to provide system components and sub-assemblies for high-end automation.

Moog Animatics is dedicated to delivering component-level products and subsystem assemblies with high performance and reliability at the lowest possible prices. Our coupled subsystems allow you to just drop us in and go!

**Low-Cost Breakthrough**

Lowering cost without sacrificing quality, accuracy or system integrity is the number one topic and goal on the minds of the board of directors and management of every major company in the world. Today, the goal is achievable without resorting solely on the old-fashioned, cost-cutting methods of reducing US. and European employees in favor of offshore suppliers. Moog Animatics now has a fully integrated linear motion system that reduces costs by reducing system parts and components as well as engineering and assembly time — through innovation.

H-Bot dual-axis gantry systems greatly reduce system cost by providing a sturdy X-Y platform to move material using a single belt and eliminating the need for costly cable management systems. The motors remain motionless! Combined with Moog Animatics SmartMotor intelligence, transforms from Cartesian coordinates to H-Bot coordinates are done quickly and easily on the fly.

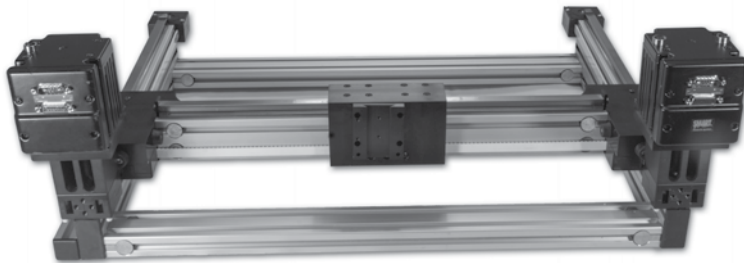

**30-35% Savings on System Costs with HLD**

Integrated SmartMotor™ technology is the invention of Moog Animatics. “Harmonic Linear Drive™” belt actuator technology is the invention of Harmonic Linear Drives, Ltd. in England. The merging of these two technologies can save up to 35% when compared to the equivalent, conventional components. For any given axis of motion, this system design approach provides linear bearing load support, harmonic zero-backlash gear reduction, a true closed-loop brushless motor and digital drive, and a 32-bit programmable controller. The Intrinsic reduction provides a high resistance to backdriving, a benefit usually purchased in the form of a brake. The SmartMotor eliminates a cabinet full of controls by building everything into the motor. The Harmonic Linear Drive eliminates a gearhead and brake by wrapping the belt around subtly different diameter pulleys in a way that produces inherent gear reduction using the Harmonic Principle. This clever, compact combination uses fewer parts, increases reliability and markedly lowers the cost of your machine.

*All Moog Animatics Linear Integrated Systems are covered by Moog Animatics patent #5,912,541 and other patents are in progress worldwide.*

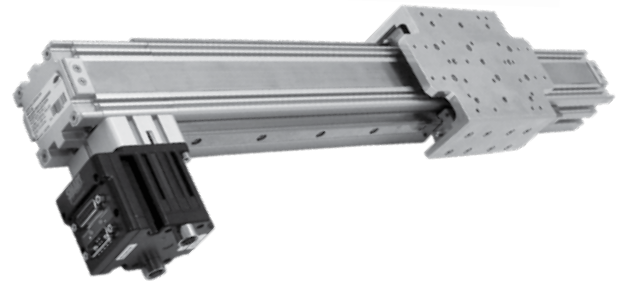
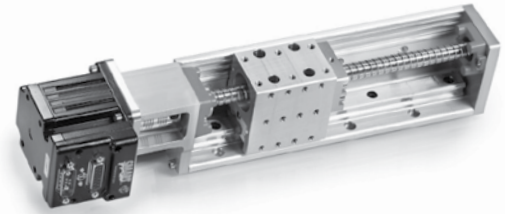

With over 20 years of application designs operating on production floors internationally, we offer high-performance, low-cost, reliable components and subsystems for industries including, but not limited to:

- **Consumable Product Packaging Machines**
- **Semiconductor Wafer and Chip Processing**
- **Biomedical Process and Control Equipment**
- **Automotive Component Assembly and Testing**
- **CNC Wood and Metal Cutting Systems**
- **Aviation Testing and Control**
- **Nuclear Fuel Rod Handling Systems**

Overview

Software

C5 D-Style

C5 M-Style

C6 M-Style

C6 Low-Cost

Cables, Etc.

**Actuators**

Gearheads

Power Supplies

## Part Numbering Examples

### 1. Overview

<b>H3</b>	–	<b>0050</b>	–	<b>025</b>	–	<b>A</b>	–	<b>A</b>		<b>N</b>
Actuator Type		Stroke Length		Effective Pitch		Style/Option/Reduction		Interface		Special
<b>H3</b> = HLD60 <b>L1</b> = L70 <b>M6S</b> = M6S <b>PSC</b> = PSC <b>VLCT35</b> = VL-CT35 <b>VLCT45</b> = VL-CT45 <b>VLCT55</b> = VL-CT55 <b>VLST45</b> = VL-ST45 <b>VLST60</b> = VL-ST60 <b>X1</b> = XL100		Examples: <b>0050</b> = 50 mm <b>0700</b> = 700 mm <b>2500</b> = 2500 mm		Examples: <b>025</b> = 2.5 mm/rev <b>050</b> = 5.0 mm/rev <b>060</b> = 6.0 mm/rev <b>100</b> = 10.0 mm/rev <b>120</b> = 12.0 mm/rev <b>125</b> = 12.5 mm/rev		<b>A</b> = Internal rollers <b>B</b> = Single external rail <b>E</b> = Twin external rails <b>R</b> = Rolled ball screw <b>S</b> = Standard <b>0</b> = No reduction <b>3</b> = 3:1 Reduction <b>5</b> = 5:1 Reduction <b>7</b> = 7:1 Reduction <b>10</b> = 10:1 Reduction		<b>A</b> = 1/4 in Input shaft <b>B</b> = 3/8 in Input shaft (NEMA 23) <b>C</b> = 10 mm Input shaft <b>D</b> = 3/8 in Input shaft (NEMA 34) <b>E</b> = 1/2 in Input shaft  NOTE: For proper input size, always check the shaft diameter on the motor dimension drawing.		<b>N</b> = No special options <b>L</b> = Left hand motor orientation <b>R</b> = Right hand motor orientation <b>LS</b> = Left hand, rail on motor side <b>RS</b> = Right hand, rail on motor side <b>P1</b> = 1:1 Pulley offset <b>P2</b> = 2:1 Pulley offset <b>P3</b> = 3:1 Pulley offset

### 2. Motor Information

When ordering actuators with motors, use the actuator part number (following the format above) entered first on the Purchase Order (PO). The motor part number is entered on the PO on the line following the actuator it is to be mounted on. Refer to the following example.

Line	Part Number	Description
1	H3-0306-100E-AL	HLD60 Belt Actuator, 306 mm (12.0 in), 10.0 mm/rev pitch, double rail, NEMA 23 motor mount with 1/4 in input shaft, and left hand motor orientation
2	SM23165DT	Size 23165D Class 5, HI Torque

**NOTE:** There are no “O’s” in the part number, only zeros. For more details, see the website for Part Number Generator at [www.animatics.com/pngenerator](http://www.animatics.com/pngenerator) or call (650) 960-4216. PSC, M6S, ROT1 and HBOT use slightly different part number schemes -- see pagespage 35-page 38 for details.



		HLD60 with Internal Rollers				HLD60 with External Rail				HLD60 with Twin External Rails			
Actuator Type		Harmonic Belt				Harmonic Belt				Harmonic Belt			
Standard Stroke Lengths	mm	100 – 600 mm in 50 mm Steps				100 – 600 mm in 50 mm Steps				100 – 600 mm in 50 mm Steps			
		600 – 1000 mm in 100 mm Steps				600 – 1000 mm in 100 mm Steps				600 – 1000 mm in 100 mm Steps			
		1000 – 2200 mm in 200 mm Steps				1000 – 2200 mm in 200 mm Steps				1000 – 2200 mm in 200 mm Steps			
Unidirectional Repeatability	µm	<20											
Bidirectional Repeatability	µm	60 - 180											
Linear Accuracy	mm/mm	0.5 / 300				0.5 / 300				0.5 / 300			
Displacement/rev	mm/rev	2.5	5	10	12.5	2.5	5	10	12.5	2.5	5	10	12.5
Max. Linear Speed <sup>(1)</sup> (No Load)	mm/sec	200	391	782	977	200	391	782	977	200	391	782	914
Continuous Thrust <sup>(2)</sup>	N	450	420	185	135	450	420	185	135	450	400	160	105
Payload Mass	kg	45	42	18	13	45	42	18	13	45	40	16	10
<b>Carriage Moments, Dynamic <sup>(3)</sup>, (Static)</b>													
Carriage Moments, M.a <sup>(3)</sup>	Nm	1.0 (2.4)	0.80 (2.4)	0.6 (2.4)	0.55 (2.4)	19 (24)	15 (24)	12 (24)	11 (24)	180 (200)	144 (200)	114 (200)	106 (200)
Carriage Moments, M.b <sup>(3)</sup>	Nm	3.2 (8)	2.5 (8)	2.0 (8)	1.9 (8)	72 (200)	57 (200)	45 (200)	42 (200)	144 (200)	113 (200)	89 (200)	84 (200)
Carriage Moments, M.c <sup>(3)</sup>	Nm	3.2 (12)	2.5 (12)	2.0 (12)	1.9 (12)	72 (150)	57 (150)	45 (150)	42 (150)	144 (200)	113 (200)	89 (200)	84 (200)
Overall Length	mm	Stroke + 332				Stroke + 332				Stroke + 332			
Overtravel	mm	25				25				25			
Unit Mass	kg	2.3 + 0.0031 x (Stroke, mm) + (Motor mass, kg)				2.7 + 0.0044 x (Stroke, mm) + (Motor mass, kg)				3.4 + 0.0057 x (Stroke, mm) + (Motor mass, kg)			

**NOTE: For part numbers please refer to our Website at [www.animatics.com](http://www.animatics.com)**

<sup>(1)</sup> Based on using SM23165DT @ 48V @ 4200 RPM no load. Refer to corresponding thrust curves on website for details.

<sup>(2)</sup> Based on using SM23165DT @ 48V @ 3600 RPM. Refer to corresponding thrust curves on website for details.

<sup>(3)</sup> Based on a 15000 hr service life @ 75 / 150 / 300 and 375 mm/s (1800 RPM) average speed at the given payload subject to routine lubrication.



		L70		XL100		VL-ST				VL-CT					
<b>Ball Screw Actuator Type</b>		<b>Rodless</b>		<b>Rodless</b>		<b>Rodless</b>				<b>Rod</b>					
Standard Stroke Lengths	mm	50 – 600 mm in 50 mm Steps		50 – 600 mm in 50 mm Steps		VL-ST45 = 50 – 500 mm; VL-ST60 = 50 – 600 mm; in 50 mm Steps				VL-CT35 = 50 – 150 mm; VL-CT45 = 50 – 200 mm; VL-CT55 = 50 – 300 mm; in 50 mm Steps					
Unidirectional Repeatability	µm	3		3		20				20					
Bidirectional Repeatability	µm	16		16		40				40					
Linear Accuracy	mm/mm	0.21 / 300		0.21 / 300		0.21 / 300				0.21 / 300					
Displacement/rev	mm/rev	5	10	5	10	VL-ST45		VL-ST60		6	12				
						6	12	6	12						
Max. Linear Speed <sup>(4)</sup>	mm/sec	350 <sup>(4)</sup>	910 <sup>(4)</sup>	350 <sup>(4)</sup>	910 <sup>(4)</sup>	500 <sup>(4)</sup>	1000 <sup>(4)</sup>	500 <sup>(4)</sup>	1000 <sup>(4)</sup>	500 <sup>(4)</sup>	1000 <sup>(4)</sup>				
Continuous Thrust <sup>(5)</sup>	N	587	294	587	294	260	135	490	250	<b>Pulley Reduction</b>					
										1:1	2:1	3:1	1:1	2:1	3:1
		461	922	1383	231	461	692								
Payload Mass	kg	25	20	25	20	8	6.5	13	10	VL-CT35	VL-CT45	VL-CT55	VL-CT35	VL-CT45	VL-CT55
										7	7	27.5	5.6	5.6	22
<b>Carriage moments, Dynamic <sup>(7)</sup>, (Static)</b>															
Carriage Moments, M.a <sup>(7)</sup>	Nm	5 (20)		25 (500)		4.47 (31)	3.44 (31)	11.47 (58)	9 (58)	0					
Carriage Moments, M.b <sup>(7)</sup>	Nm	5 (20)		25 (500)		1.64 (12)	1.33 (12)	3.57 (25)	2.75 (25)	0					
Carriage Moments, M.c <sup>(7)</sup>	Nm	5 (20)		25 (500)		1.64 (12)	1.33 (12)	3.57 (25)	2.75 (25)	0					
Overall Length	mm	Stroke + 182.5 + Motor		Stroke + 223.5 + Motor		VL-ST45 = Stroke + 164 + Motor; VL-ST60 = Stroke + 222 + Motor				VL-CT35 = Stroke + 244.9 + Motor; VL-CT45 = Stroke + 251.4 + Motor; VL-CT55 = Stroke + 274.9 + Motor					
Overtravel	mm	24.5		24		10				None					
Unit Mass	kg	1.29 + 0.00414 x (Stroke, mm) + (Motor mass, kg)		2.657 + 0.0049 x (Stroke, mm) + (Motor mass, kg)		VL-ST45 = 1.38 + 0.0021 x (Stroke, mm) + (Motor mass, kg) VL-ST60 = 1.3349 + 0.0039 x (Stroke, mm) + (Motor mass, kg)				VL-CT35 = 1.1667 + 0.003 x (Stroke, mm) + (Motor mass, kg) VL-CT45 = 1.45 + 0.0052 x (Stroke, mm) + (Motor mass, kg) VL-CT55 = 1.94 + 0.0075 x (Stroke, mm) + (Motor mass, kg)					

**NOTE: For part numbers please refer to our website at [www.animatics.com](http://www.animatics.com)**

<sup>(4)</sup> Please see Ball Screw CRITICAL SPEED limitations on corresponding product pages of website for details.

<sup>(5)</sup> Based on using SM23165DT @ 48V @ 2000 RPM. Refer to corresponding thrust curves on website for details.

<sup>(6)</sup> Based on using the VL-CT55 with SM23165DT. Max thrust for the VL-CT35/45 is 565N.

<sup>(7)</sup> For L70 and XL100, based on a 15000 hr service life @ 167 mm/s and 333 mm/s (2000 RPM) average speed at the given payload, subject to routine lubrication. For VL series, based on a 15000 hr service life @ 200 mm/s and 400 mm/s (2000 RPM) average speed at the given payload, subject to routine lubrication.

The Moog Animatics PSC actuator is a belt-driven linear system with integrated guide rails, low backlash and high traverse speeds. These actuators are ideal for moving light loads at speeds beyond the reach of ball screw actuators. These fully integrated actuator products bring SmartMotor™ capabilities, ease of use, and speed to market to your actuator applications. They are designed for precise motion, long life and minimal maintenance, making them an ideal fit for applications in material handling, packaging, biomedical, semiconductor, life sciences and more. These actuators are available with strokes from 150 mm to 3000 mm in 50 mm increments (other lengths are available by special request). The PSC actuator is shipped preassembled with the NEMA 23 Moog Animatics SmartMotor of your choice \*. The motor can be mounted on either side of the actuator for maximum design and mounting flexibility. These actuators can also be ordered as a complete T-Bot (vertical) or H-Bot (horizontal) two-axis gantry system.

*\*Due to inertial mismatch, SmartMotor models SM23165D and SM23165DT are not recommended for direct drive of the PSC actuators. The addition of a gearhead may be required for any application exceeding a 10:1 load to motor mismatch.*

### Key Features

- Extruded aluminum actuator body with T-slots
- Integrated belt tensioner
- One piece, machined, stress-proof, shafted pulley
- Zero-backlash, belt-to-pulley design
- Corrosion-resistant components

### Key Benefits

- Save time on mounting
- Maintain positional accuracy if belt stretches
- Long service life
- No need for linear encoder to increase precision
- Suitable for splash-prone environments



### Technical Specifications

PSC Size and Data			
Actuator Specifications		Motor Sizing Information	
Motion	Horizontal or Vertical	Weight of Drive Pulley, oz [kg]	4.7 [0.13]
Max. Speed - Horizontal [Vertical], mm/sec	1270 [635]	Weight of Idler Pulley, oz [kg]	4.3 [0.12]
Max. Load - Horizontal [Vertical], N	90 [90]	Weight of Cart, lb [kg]	0.4 [0.18]
Unidirectional Repeatability, μm	± 25	Weight of Belt, kg Based on Travel Selected	((Travel in Meters x 2) + .32) x .04
Bidirectional Repeatability, μm			
Max. Moment Load, in-lb [Nm]	15 [1.7]	Coupling	Flexible Jaw
Positional Accuracy, mm/mm	0.12 per 300 stroke	Displacement/Rev, mm	105
Acceleration Maximum, g	5	Pulley Pitch Diameter, mm	33.42
Beam Dimensions, mm	28 x 38	Pulley Material/Width, mm	Steel, 12
Ultimate Tensile Strength of Belt, lb [N]	800 [3559]	Breakaway Torque, oz-in	12 – 14
Recommended Belt Running Load, lb [N]	200 [889]	Coefficient of Friction	0.25
Available Stroke, mm	150 – 3000 in 50 mm steps	Rolling Resistance, lb [kg]	0.008 [0.004]
Available Gear Reductions	None, 3:1, 5:1, 7:1, 10:1	<b>Weight</b>	
Overall Length	Stroke + 480	Unit Mass	1.6 + 0.0016 x (stroke, mm) + (motor mass, kg)

### Part Numbering System Guide

For more details, see [www.animatics.com/psc](http://www.animatics.com/psc)

Also, see the Part Number Generator at [www.animatics.com/pngenerator](http://www.animatics.com/pngenerator)

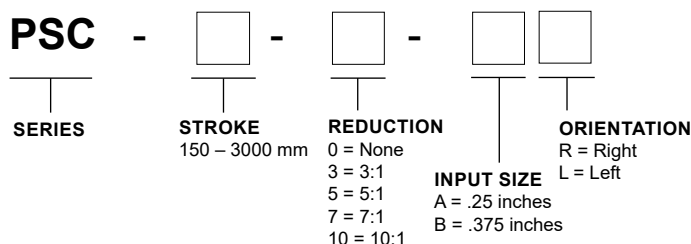



The Moog Animatics M6S actuator is a belt-driven linear system with integrated guide rails, low backlash and high traverse speeds. These actuators are ideal for moving light loads at speeds beyond the reach of ball screw actuators. These fully integrated actuator products bring SmartMotor™ capabilities, ease of use, and speed to market to your actuator applications. They are designed for precise motion, long life and minimal maintenance, making them an ideal fit for applications in material handling, packaging, biomedical, semiconductor, life sciences and more. These actuators are available with strokes from 150 mm to 3000 mm in 50 mm increments (other lengths are available by special request). The M6S actuator is shipped preassembled with the NEMA 34 Moog Animatics SmartMotor of your choice \*. The motor can be mounted on either side of the actuator for maximum design and mounting flexibility. These actuators can also be ordered as a complete T-Bot (vertical) or H-Bot (horizontal) two-axis gantry system.

\*Due to inertial mismatch, SmartMotor models SM34165D and SM34165DT are not recommended for direct drive of the M6S actuators. The addition of a gearhead may be required for any application exceeding a 10:1 load to motor mismatch.

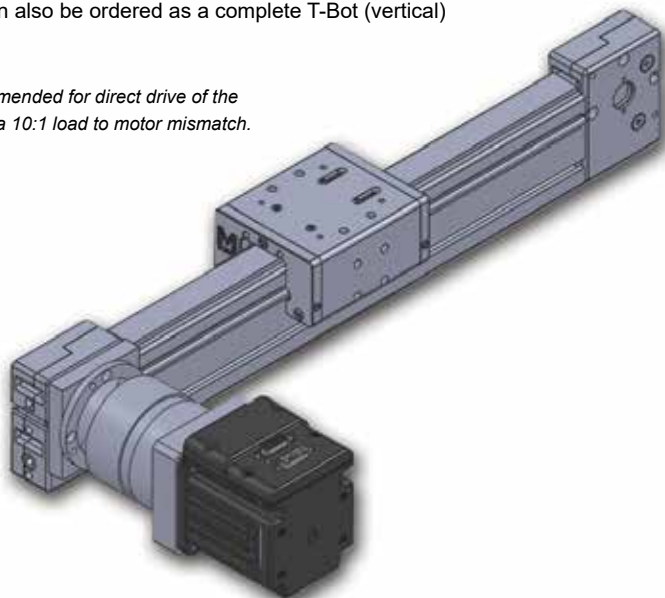

### Key Features

- Extruded aluminum actuator body with T-slots
- Integrated belt tensioner
- One piece, machined, stress-proof, shafted pulley
- Zero-backlash, belt-to-pulley design
- Corrosion-resistant components

### Key Benefits

- Save time on mounting
- Maintain positional accuracy if belt stretches
- Long service life
- No need for linear encoder to increase precision
- Suitable for splash-prone environments

### Technical Specifications

M6S Size and Data			
Actuator Specifications		Motor Sizing Information	
Motion	Horizontal or Vertical	Weight of Drive Pulley, oz [kg]	11.3 [0.32]
Max. Speed - Horizontal [Vertical], mm/sec	6230 [3115]	Weight of Idler Pulley, oz [kg]	7.7 [0.22]
Max. Load - Horizontal [Vertical], N	222 [111]	Weight of Cart, lb [kg]	3.5 [1.59]
Unidirectional Repeatability, µm	± 25	Weight of Belt, kg	((Travel in Meters x 2) + .47) x .12
Bidirectional Repeatability, µm		Based on Travel Selected	
Max. Moment Load, in-lb [Nm]	25 [2.8]	Coupling	Flexible Jaw
Positional Accuracy, mm/mm	0.12 per 300 stroke	Displacement/Rev, mm	150
Acceleration Maximum, g	9	Pulley Pitch Diameter, mm	47.74
Beam Dimensions, mm	40 x 80	Pulley Material/Width, mm	Steel, 25
Ultimate Tensile Strength of Belt, lb [N]	1750 [7787]	Breakaway Torque, oz-in	30 – 32
Recommended Belt Running Load, lb [N]	437 [1945]	Coefficient of Friction	N/A
Available Stroke, mm	150 – 3000 in 50 mm steps	Rolling Resistance, lb [kg]	0.008 [0.004]
Available Gear Reductions	None, 3:1, 5:1, 7:1, 10:1	<b>Weight</b>	
Overall Length	Stroke + 331	Unit Mass	5.8 + 0.0012 x (stroke, mm) + (motor mass, kg)

### Part Numbering System Guide

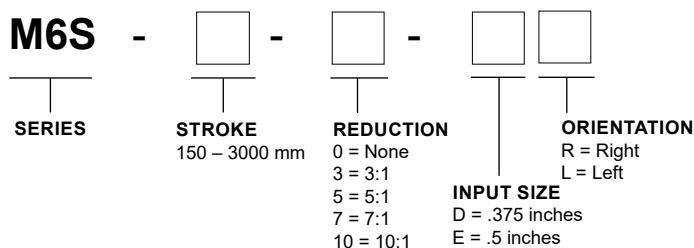

For more details, see [www.animatics.com/m6s](http://www.animatics.com/m6s)

Also, see the Part Number Generator at [www.animatics.com/pngenerator](http://www.animatics.com/pngenerator)

The Moog Animatics ROT1 rotary actuator is a belt-driven rotary stage with low backlash and high positional accuracy. This family of rotary actuator products is ideal for high-speed indexing as well as precision rotation. With the Moog Animatics ROT1 series of rotary actuators, you will have a turnkey, easy-to-use solution for all rotary-table applications requiring moderate to high loads. These rotary stages are available with through holes from 16 mm to 100 mm, and with optional cleanroom-compliant grease. The ROT1 rotary actuator is shipped preassembled with the Moog Animatics SmartMotor™ of your choice.\* The motor can be mounted on either side of the stage to accommodate the space requirements of your application.

*\*Due to inertial mismatch, SmartMotor models SM23165D and SM23165DT are not recommended for direct drive of the ROT1 rotary actuators. The addition of a gearhead may be required for any application exceeding a 10:1 load to motor mismatch.*

## Key Features

- Preloaded duplex angular contact bearings
- Open through-hole
- Integrated belt reduction
- Aluminum construction

## Key Benefits

- High load capacity, long service life
- Wire/material pass-through
- Low backlash, high positional accuracy
- Strong but lighter weight than cast iron tables

## Technical Specifications



ROT1 Size and Data

	3:1 Belt Drive Rotary		5:1 Belt Drive Rotary	
	ROT1-0016	ROT1-0050	ROT1-0025	ROT1-0100
Type	3:1 Belt Drive Rotary		5:1 Belt Drive Rotary	
Bearing Type	Preloaded Duplex Angular Contact			
Stage Diameter/Height, mm	100 / 50	100 / 54	165 / 54	165 / 60.6
Through-Hole	16.0 mm	50.8 mm	25.4 mm	101.6 mm
Accuracy (± arc-sec)	108		65	
Kinematic Wobble (± arc-sec)	8		16	
Kinematic Radial Runout (µm TIR)	13		20	
Table Top Parallelism To Base (µm TIR)	80		80	
Bidirectional Repeatability (± arc-sec)	120		40	
Unidirectional Repeatability (± arc-sec)	30		12	
Table Resolution	12000 ct/rev		20000 ct/rev	
Speed Limit (RPM)	1300		800	
Load Capacity Axial/Radial (kN)	14.0 / 26.0	8.6 / 7.7	48.0 / 39.0	14.0 / 11.7
Max. Moment (N-m)	480	120	1150	370
Rotational Inertia (kg/m <sup>2</sup> )	0.00048	0.00051	0.0033	0.006
Stage Weight (kg, without motor)	1.55	1.32	3.2	2.8
Recommended Payload Maximum (kg)	10		25	

For more details, see [www.animatics.com/rot1](http://www.animatics.com/rot1)

Also, see the [Part Number Generator](http://www.animatics.com/pngenerator) at [www.animatics.com/pngenerator](http://www.animatics.com/pngenerator)

Overview

The Moog Animatics H-Bot belt systems use a novel combination of belt actuators to accomplish two-axis motion. The motors remain stationary, removing the traditional requirement for expensive cable tracks and associated high-flex cabling. The intelligence in the SmartMotor™ simplifies and makes motion solutions easy, as the SmartMotor can interpret direct Cartesian coordinates and perform the transforms on the fly to create exactly the motion and positioning you require. The H-Bot belt systems are shipped preassembled with the Moog Animatics SmartMotor of your choice.

Software

**Key Features**

- Low backlash design
- Adjustable belt tension
- Stroke from 250 – 1000 mm in X and Y axes
- Single belt design
- Inverse kinematics on SmartMotor

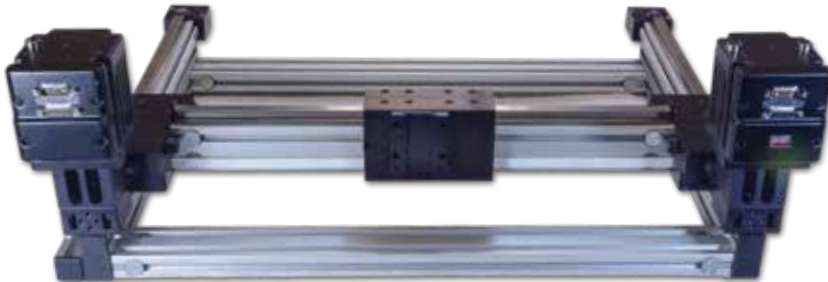

C5 D-Style

**Key Benefits**

- Precise and accurate positioning for low to medium loads
- Small footprint, appropriate for tabletops and laboratories
- Mechanically simple, robust and reliable
- SmartMotor inverse kinematics simplify programming
- Reduced development time and investment

C5 M-Style

**Technical Specifications**

HBOT1 Size and Data			
Actuator Specifications		Motor Sizing Information	
Max. Linear Speed, mm/s	1000	Pulley Size, mm	12
Recommended Payload Maximum, lb	10	Weight of Single Shafted Drive Pulley, oz [kg]	4.7 [0.13]
Bidirectional Repeatability, µm	±50	Weight of Idler Pulley, oz [kg]	4.3 [0.12]
Accuracy, mm/mm	0.24 per 300 Stroke	Weight of Complete Y-Axis Beam (Based on Travel), lb [kg]	15 to 40 [6.8 to 18.1]
Maximum Acceleration, g	10 (Dependent on Payload)		
Ultimate Tensile Strength of Belt, lb [N]	800 [3559]	Weight of Cart, lb [kg]	5 [2.3]
Recommended Continuous Load, lb [N]	200 [889]	Displacement/Rev., mm	105
Physical Parameters		Pulley Pitch Diameter, mm	33.42
X-Stroke, mm	250 – 1000 in 250 mm Steps	Coefficient of Friction, Multiplier/lb	0.05
Y-Stroke, mm	250 – 1000 in 250 mm Steps	Pulley Material/Width, mm	Steel / 12
Unit Weight (Based on Stroke), lb	(18 to 42) + (2x motor mass)		

C6 M-Style

C6 Low-Cost

Cables, Etc.

**Part Numbering System Guide**

For more details, see [www.animatics.com/hbot1](http://www.animatics.com/hbot1)  
 Also, see the Part Number Generator at [www.animatics.com/pngenerator](http://www.animatics.com/pngenerator)

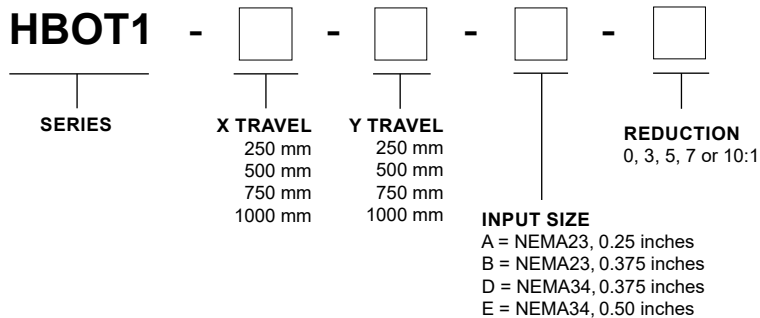

Actuators

Gearheads

Power Supplies

All units are precision-ground, planetary gearsets capable of sustained servo input speed. They can be ordered by themselves or pre-mounted to the SmartMotor™ before shipment.

Each gearhead has a non-captive input pinion gear. This means the pinion is mounted onto the motor shaft and the gearhead is then mounted onto the motor flange.

Torque throughputs for in-line (straight) gearheads are limited by input pinion diameters.

Typically, the 7:1 ratio single-stage and 28:1 ratio two-stage gearheads have the higher torque ratings.

10:1 and 100:1 gearhead input pinions are very small. Therefore, great care should be taken not to exceed maximum torque ratings for those gear ratios.

All right angle gearhead torque levels are limited by the right angle beveled gear sets. This is why all gear ratios show the same torque limits within that series.

All gearheads are limited to a maximum of 5000 RPM input pinion speed. This limit is due to differential speed across the input pinion bearings and lubrication flow. Exceeding 5000 RPM for any sustained period will GREATLY decrease the life of the gearhead and will not be covered by warranty. However, for typical servo applications, there is no issue with reaching 5000 RPM on each machine cycle's peak speeds.

Please consult the website or factory for load specifications. Load ratings are speed dependent and are charted across curves.



Gearhead Series	Backlash (arc-minutes)	
	Single-Stage	Two-Stage
High Performance (P)	6	10
OEM Series (SP)	12	16
Right Angle (RAP)	10	14

Moog Animatics provides three series of gearheads. The above chart is a quick reference to backlash specs.

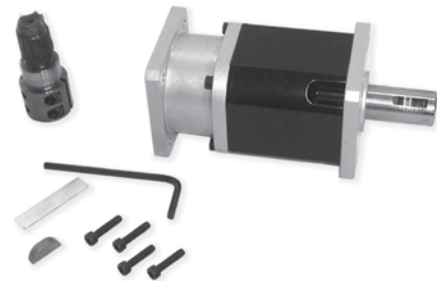

Each gearhead is shipped with appropriate mounting hardware, fasteners, Allen key and pinion gap gauge.

Please see the website for mounting instructions:  
 NEMA 17 Frame – [www.animatics.com/gh17-install](http://www.animatics.com/gh17-install)  
 NEMA 23 Frame – [www.animatics.com/gh23-install](http://www.animatics.com/gh23-install)  
 NEMA 34 Frame – [www.animatics.com/gh34-install](http://www.animatics.com/gh34-install)

### Two Stage Gearheads Shown

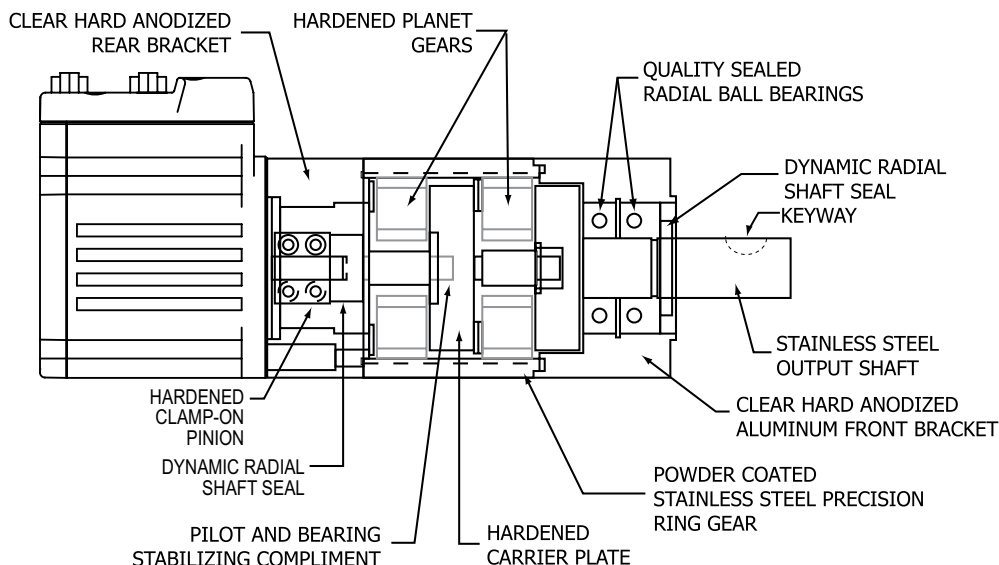

**⚠ WARNING: Improper assembly of motor to gear head could result in product damage and will not be covered under warranty. Please consult the factory for details.**

**OEM Series**

Part #	Ratio	Continuous output torque at 1500 rpm input (in-lbs)	Continuous output torque at 3500 rpm input (in-lbs)	Continuous output torque at 5000 rpm input (in-lbs)	Gearhead inertia at input (lb-in-sec <sup>2</sup> )
<b>Single Stage</b>					
GH17SP004	4:1	75	57	49	1.28 x 10 <sup>-5</sup>
GH17SP007	7:1	60	51	46	7.65 x 10 <sup>-6</sup>
GH17SP010	10:1	48	43	39	6.69 x 10 <sup>-6</sup>
<b>Double Stage</b>					
GH17SP016	16:1	81	74	70	1.27 x 10 <sup>-5</sup>
GH17SP028	28:1	83	79	76	7.63 x 10 <sup>-6</sup>
GH17SP049	49:1	61	59	58	7.55 x 10 <sup>-6</sup>
GH17SP070	70:1	61	60	59	6.64 x 10 <sup>-6</sup>
GH17SP100	100:1	47	46	46	6.63 x 10 <sup>-6</sup>

**General Specifications**

Construction Type	Ratio	Standard Backlash (arc-minutes)	Efficiency	Weight (lbs)	Maximum Tested Input rpm	Standard Input Shaft Diameter (in)
Single Stage	4:1 to 10:1	12	95%	0.59	5000	0.197
Double Stage	16:1 to 100:1	16	90%	0.88	5000	0.197

NOTE: Please consult the website or factory for load specifications. PEAK TORQUE: 15% above continuous rating.

**⚠ WARNING:** Repeated peak-torque loading may cause failure and will void the warranty.

**High-Performance Series**

Part #	Ratio	Continuous output torque at 1500 rpm input (in-lbs)	Continuous output torque at 3500 rpm input (in-lbs)	Continuous output torque at 5000 rpm input (in-lbs)	Gearhead inertia at input (lb-in-sec <sup>2</sup> )
<b>Single Stage</b>					
GH17P3	3:1	197	140	115	3.25 x 10 <sup>-5</sup>
GH17P4	4:1	177	136	116	1.60 x 10 <sup>-5</sup>
GH17P5.5	5.5:1	157	129	113	1.10 x 10 <sup>-5</sup>
GH17P7	7:1	143	122	110	9.56 x 10 <sup>-6</sup>
GH17P10	10:1	113	101	93	8.36 x 10 <sup>-6</sup>
<b>Double Stage</b>					
GH17P16	16:1	211	194	182	1.59 x 10 <sup>-5</sup>
GH17P22	22:1	216	201	193	1.10 x 10 <sup>-6</sup>
GH17P28	28:1	218	207	199	9.54 x 10 <sup>-6</sup>
GH17P40	40:1	220	212	207	8.35 x 10 <sup>-6</sup>
GH17P49	49:1	158	154	152	9.44 x 10 <sup>-6</sup>
GH17P55	55:1	183	177	175	8.31 x 10 <sup>-6</sup>
GH17P70	70:1	160	156	154	8.30 x 10 <sup>-6</sup>
GH17P100	100:1	122	120	119	8.29 x 10 <sup>-6</sup>

**General Specifications**

Construction Type	Ratio	Standard Backlash (arc-minutes)	Efficiency	Weight (lbs)	Maximum Tested Input rpm	Standard Input Shaft Diameter (in)
Single Stage	3:1 to 10:1	6	90%	1.14	5000	0.197
Double Stage	16:1 to 100:1	10	85%	1.62	5000	0.197

NOTE: Please consult the website or factory for load specifications. PEAK TORQUE: 15% above continuous rating.

**⚠ WARNING:** Repeated peak-torque loading may cause failure and will void the warranty.



## OEM Series

Part #	Ratio	Continuous output torque at 1500 rpm input (in-lbs)	Continuous output torque at 3500 rpm input (in-lbs)	Continuous output torque at 5000 rpm input (in-lbs)	Gearhead inertia at input (lb-in-sec <sup>2</sup> )
<b>Single Stage</b>					
GH23SP4	4:1	185	133	109	4.19 x 10 <sup>-5</sup>
GH23SP7	7:1	155	126	110	1.54 x 10 <sup>-5</sup>
GH23SP10	10:1	125	107	97	1.08 x 10 <sup>-5</sup>
<b>Double Stage</b>					
GH23SP16	16:1	214	190	175	4.26 x 10 <sup>-5</sup>
GH23SP28	28:1	223	208	197	1.57 x 10 <sup>-5</sup>
GH23SP49	49:1	164	158	154	1.52 x 10 <sup>-5</sup>
GH23SP70	70:1	166	161	158	1.06 x 10 <sup>-5</sup>
GH23SP100	100:1	126	124	122	1.06 x 10 <sup>-5</sup>

## General Specifications

Construction Type	Ratio	Standard Backlash (arc-minutes)	Efficiency	Weight (lbs)	Maximum Tested Input rpm	Standard Input Shaft Diameter (in)*
Single Stage	4:1 to 10:1	12	95%	1.55	5000	0.25
Double Stage	16:1 to 100:1	16	85%	1.95	5000	0.25

\*NOTE: When using with SM23165MT series motors: All gearheads above come standard with 1/4 inch diameter input shaft. For gearheads requiring a 0.375 inch shaft input, please add "-0.375" to the part number. Example: GH23P4-0.375 will provide a 0.375 inch input shaft diameter.

NOTE: Please consult the website or factory for load specifications. PEAK TORQUE: 15% above continuous rating.

**⚠ WARNING:** Repeated peak-torque loading may cause failure and will void the warranty.

## High-Performance Series

Part #	Ratio	Continuous output torque at 1500 rpm input (in-lbs)	Continuous output torque at 3500 rpm input (in-lbs)	Continuous output torque at 5000 rpm input (in-lbs)	Gearhead inertia at input (lb-in-sec <sup>2</sup> )
<b>Single Stage</b>					
GH23P3	3:1	442	292	232	1.22 x 10 <sup>-4</sup>
GH23P4	4:1	410	294	242	5.24 x 10 <sup>-5</sup>
GH23P5.5	5.5:1	373	288	247	2.65 x 10 <sup>-5</sup>
GH23P7	7:1	344	279	245	1.93 x 10 <sup>-5</sup>
GH23P10	10:1	277	238	215	1.35 x 10 <sup>-5</sup>
<b>Double Stage</b>					
GH23P16	16:1	521	463	427	5.32 x 10 <sup>-5</sup>
GH23P22	22:1	536	490	460	2.70 x 10 <sup>-5</sup>
GH23P28	28:1	545	506	481	1.96 x 10 <sup>-5</sup>
GH23P40	40:1	553	525	506	1.36 x 10 <sup>-5</sup>
GH23P49	49:1	400	385	375	1.90 x 10 <sup>-5</sup>
GH23P55	55:1	460	443	432	1.34 x 10 <sup>-5</sup>
GH23P70	70:1	404	393	385	1.33 x 10 <sup>-5</sup>
GH23P100	100:1	308	303	298	1.33 x 10 <sup>-5</sup>

## General Specifications

Construction Type	Ratio	Standard Backlash (arc-minutes)	Efficiency	Weight (lbs)	Maximum Tested Input rpm	Standard Input Shaft Diameter (in)*
Single Stage	3:1 to 10:1	6	90%	2.29	5000	0.25
Double Stage	16:1 to 100:1	10	85%	3.42	5000	0.25

\*NOTE: When using with SM23165MT series motors: All gearheads above come standard with 1/4 inch diameter input shaft. For gearheads requiring a 0.375 inch shaft input, please add "-0.375" to the part number. Example: GH23P4-0.375 will provide a 0.375 inch input shaft diameter.

NOTE: Please consult the website or factory for load specifications. PEAK TORQUE: 15% above continuous rating.

**⚠ WARNING:** Repeated peak-torque loading may cause failure and will void the warranty.

**OEM Series**

Part #	Ratio	Continuous output torque at 1500 rpm input (in-lbs)	Continuous output torque at 3500 rpm input (in-lbs)	Continuous output torque at 5000 rpm input (in-lbs)	Gearhead inertia at input (lb-in-sec <sup>2</sup> )
<b>Single Stage</b>					
GH34SP004	4:1	529	350	279	1.28 x 10 <sup>-4</sup>
GH34SP007	7:1	467	355	301	7.65 x 10 <sup>-5</sup>
GH34SP010	10:1	384	313	275	6.69 x 10 <sup>-5</sup>
<b>Double Stage</b>					
GH34SP016	16:1	667	566	508	1.27 x 10 <sup>-4</sup>
GH34SP028	28:1	670	639	595	7.63 x 10 <sup>-5</sup>
GH34SP049	49:1	528	499	480	7.55 x 10 <sup>-5</sup>
GH34SP070	70:1	534	514	499	6.64 x 10 <sup>-5</sup>
GH34SP100	100:1	409	398	391	6.63 x 10 <sup>-5</sup>

**General Specifications**

Construction Type	Ratio	Standard Backlash (arc-minutes)	Efficiency	Weight (lbs)	Maximum Tested Input rpm	Standard Input Shaft Diameter (in)*
Single Stage	4:1 to 10:1	12	95%	3.67	5000	0.375
Double Stage	16:1 to 100:1	16	90%	5.10	5000	0.375

\*NOTE - When using with SM34165DT and SM34165MT series motors: All gearheads above come standard with 3/8 inch diameter input shaft. For gearheads requiring a 0.5 inch shaft input, please add "-0.5" to the part number. Example: GH34P3-0.5 will provide a 0.5 inch input shaft diameter.

NOTE: Please consult the website or factory for load specifications. PEAK TORQUE: 15% above continuous rating.

**⚠ WARNING:** Repeated peak-torque loading may cause failure and will void the warranty.

**High-Performance Series**

Part #	Ratio	Continuous output torque at 1500 rpm input (in-lbs)	Continuous output torque at 3500 rpm input (in-lbs)	Continuous output torque at 5000 rpm input (in-lbs)	Gearhead inertia at input (lb-in-sec <sup>2</sup> )
<b>Single Stage</b>					
GH34P3	3:1	1010	615	475	6.77 x 10 <sup>-4</sup>
GH34P4	4:1	972	643	513	2.77 x 10 <sup>-4</sup>
GH34P5.5	5.5:1	913	657	543	1.51 x 10 <sup>-4</sup>
GH34P7	7:1	859	653	554	1.11 x 10 <sup>-4</sup>
GH34P10	10:1	707	575	505	7.90 x 10 <sup>-5</sup>
<b>Double Stage</b>					
GH34P16	16:1	1350	1145	1027	2.86 x 10 <sup>-4</sup>
GH34P22	22:1	1401	1234	1133	1.55 x 10 <sup>-4</sup>
GH34P28	28:1	1432	1293	1203	1.11 x 10 <sup>-4</sup>
GH34P40	40:1	1469	1362	1293	8.04 x 10 <sup>-5</sup>
GH34P49	49:1	1067	1010	971	1.11 x 10 <sup>-4</sup>
GH34P55	55:1	1228	1165	1123	7.94 x 10 <sup>-5</sup>
GH34P70	70:1	1081	1040	1010	7.90 x 10 <sup>-5</sup>
GH34P100	100:1	827	805	790	7.87 x 10 <sup>-5</sup>

**General Specifications**

Construction Type	Ratio	Standard Backlash (arc-minutes)	Efficiency	Weight (lbs)	Maximum Tested Input rpm	Standard Input Shaft Diameter (in)*
Single Stage	3:1 to 10:1	6	90%	5.67	5000	0.375
Double Stage	16:1 to 100:1	10	85%	8.41	5000	0.375

\*NOTE - When using with SM34165DT and SM34165MT series motors: All gearheads above come standard with 3/8 inch diameter input shaft. For gearheads requiring a 0.5 inch shaft input, please add "-0.5" to the part number. Example: GH34P3-0.5 will provide a 0.5 inch input shaft diameter.

NOTE: Please consult the website or factory for load specifications. PEAK TORQUE: 15% above continuous rating.

**⚠ WARNING:** Repeated peak-torque loading may cause failure and will void the warranty.

## NEMA 17 Series

Part #	Ratio	Continuous output torque at 1500 rpm input (in-lbs)	Continuous output torque at 3500 rpm input (in-lbs)	Continuous output torque at 5000 rpm input (in-lbs)	Gearhead inertia at input (lb-in-sec <sup>2</sup> )
<b>Single Stage</b>					
GH17RAP3	3:1	80	80	80	4.96 x 10 <sup>-5</sup>
GH17RAP5.5	5.5:1	80	80	80	1.61 x 10 <sup>-5</sup>
GH17RAP7	7:1	80	80	80	1.27 x 10 <sup>-5</sup>
GH17RAP10	10:1	80	80	80	9.90 x 10 <sup>-6</sup>
<b>Double Stage</b>					
GH17RAP16	16:1	100	100	100	1.65 x 10 <sup>-5</sup>
GH17RAP22	22:1	100	100	100	1.13 x 10 <sup>-5</sup>
GH17RAP55	55:1	100	100	100	8.36 x 10 <sup>-6</sup>
GH17RAP100	100:1	100	100	100	8.31 x 10 <sup>-6</sup>

Construction Type	Ratio	Standard Backlash (arc-minutes)	Efficiency	Weight (lbs)	Maximum Tested Input rpm	Standard Input Shaft Diameter (in)
Single Stage	3:1 to 10:1	10	90%	1.96	5000	0.197
Double Stage	16:1 to 100:1	14	85%	2.44	5000	0.197

NOTE: Data and curves from the high-performance planetary gearheads may be used to size right angle planetary gearheads. PEAK TORQUE: 15% above continuous rating.

**⚠ WARNING:** Repeated peak torque loading may cause failure and will void the warranty.

## NEMA 23 Series

Part #	Ratio	Continuous output torque at 1500 rpm input (in-lbs)	Continuous output torque at 3500 rpm input (in-lbs)	Continuous output torque at 5000 rpm input (in-lbs)	Gearhead inertia at input (lb-in-sec <sup>2</sup> )
<b>Single Stage</b>					
GH23RAP3	3:1	280	280	232	2.94 x 10 <sup>-4</sup>
GH23RAP5.5	5.5:1	280	280	247	7.77 x 10 <sup>-5</sup>
GH23RAP10	10:1	277	238	215	2.90 x 10 <sup>-5</sup>
<b>Double Stage</b>					
GH23RAP16	16:1	350	350	350	5.93 x 10 <sup>-5</sup>
GH23RAP22	22:1	350	350	350	3.02 x 10 <sup>-5</sup>
GH23RAP55	55:1	350	350	350	1.39 x 10 <sup>-5</sup>
GH23RAP100	100:1	308	303	298	1.35 x 10 <sup>-5</sup>

Construction Type	Ratio	Standard Backlash (arc-minutes)	Efficiency	Weight (lbs)	Maximum Tested Input rpm	Standard Input Shaft Diameter (in)*
Single Stage	3:1 to 10:1	10	90%	4.87	5000	0.25
Double Stage	16:1 to 100:1	14	85%	6	5000	0.25

NOTE: Data and curves from the high-performance planetary gearheads may be used to size right angle planetary gearheads. PEAK TORQUE: 15% above continuous rating.

**⚠ WARNING:** Repeated peak torque loading may cause failure and will void the warranty.

\*NOTE: When using with SM23165MT series motors: All gearheads above come standard with 1/4 inch diameter input shaft. For gearheads requiring a 0.375 inch shaft input, please add "-0.375" to the part number. Example: GH23RAP3-0.375 will provide a 0.375 inch input shaft diameter.

## NEMA 34 Series

Part #	Ratio	Continuous output torque at 1500 rpm input (in-lbs)	Continuous output torque at 3500 rpm input (in-lbs)	Continuous output torque at 5000 rpm input (in-lbs)	Gearhead inertia at input (lb-in-sec <sup>2</sup> )
<b>Single Stage</b>					
GH34RAP3	3:1	525	525	475	1.20 x 10 <sup>-3</sup>
GH34RAP5.5	5.5:1	525	525	525	3.08 x 10 <sup>-4</sup>
GH34RAP10	10:1	525	525	505	1.26 x 10 <sup>-4</sup>
<b>Double Stage</b>					
GH34RAP16	16:1	656	656	656	3.05 x 10 <sup>-4</sup>
GH34RAP22	22:1	656	656	656	1.65 x 10 <sup>-4</sup>
GH34RAP55	55:1	656	656	656	8.10 x 10 <sup>-5</sup>
GH34RAP100	100:1	656	656	656	7.92 x 10 <sup>-5</sup>

Construction Type	Ratio	Standard Backlash (arc-minutes)	Efficiency	Weight (lbs)	Maximum Tested Input rpm	Standard Input Shaft Diameter (in)*
Single Stage	3:1 to 10:1	10	90%	11.89	5000	0.375
Double Stage	16:1 to 100:1	14	85%	14.62	5000	0.375

NOTE: Data and curves from the high-performance planetary gearheads may be used to size right angle planetary gearheads. PEAK TORQUE: 15% above continuous rating.

**⚠ WARNING:** Repeated peak torque loading may cause failure and will void the warranty.

\*NOTE: When using with SM34165DT and SM34165MT series motors: All gearheads above come standard with 3/8 inch diameter input shaft. For gearheads requiring a 0.5 inch shaft input, please add "-0.5" to the part number. Example: GH34P3-0.5 will provide a 0.5 inch input shaft diameter.

### Which is Better, Linear or Switcher Supplies?

Because servo motors are inductive, they may run highly dynamic motion profiles. As a result, their current demand can vary widely. Surge currents from stand still to maximum load may be extremely high, yet steady state current demand over time may be relatively mild. As a result, proper care should be taken when selecting power supplies.

Moog Animatics offers two basic types of power supplies. The chart to the right gives a brief comparison of the two types of supplies.

	Linear	Switcher
AC Input	Field Selectable (120 / 240 VAC)	Universal 90-240 VAC
Power Factor Corrected	No	Yes
Relative Size	Big and Bulky	Lightweight
Cooling	Ambient Convection	Fan Cooled
Surge Capacity	400%	5%
Voltage Regulation	15% Drop Over Range	0%, Fixed
Shunt Required? <sup>1</sup>	Occasionally, But Not Typically	In Most Cases, Highly Recommended

<sup>1</sup>See shunt section for more information

As seen in the graph to the right, linear (unregulated) supplies can handle large surge current loads. This is because linear supplies typically contain large output capacitors to handle those surges well.

Switch mode supplies (switchers) are highly regulated. They will maintain fixed voltage until they reach maximum load and then will "crowbar" to zero volts to protect the output stages. Linear supplies will slowly drop the output voltage while supplying more and more current.

This is the most fundamental difference between switchers and unregulated supplies.

Even though a switcher cannot handle the higher current surges, if it can output as much current as you would expect for a given servo application, then it will actually help the servo accelerate much faster. That is because the system voltage will be maintained at maximum level.

However, if your servo application requires surge currents in excess of 50 amps or more, the switchers may not be cost effective. For example, getting 50 amps from a Moog Animatics 20 amp supply is easy; getting 50 amps from Moog Animatics switchers would require placing multiple units in parallel. Therefore, it may not be cost effective to do so.

Voltage Drop Comparison

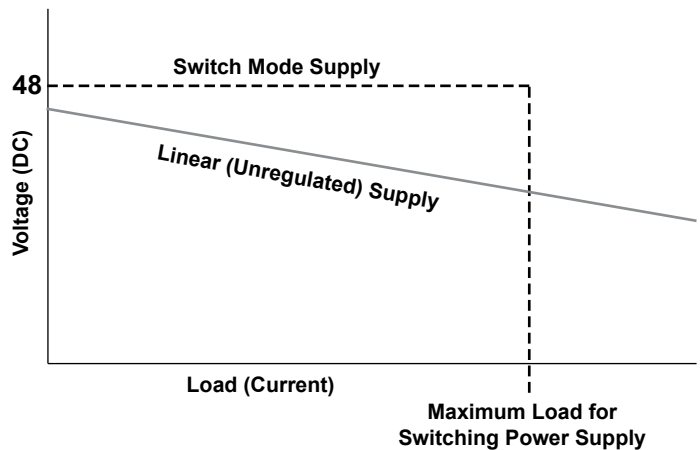

**⚠ WARNING: Improper power supply sizing may result in motor position error faults, motor resets, and machine faults.**

Overview

Software

C5 D-Style

C5 M-Style

C6 M-Style

C6 Low-Cost

Cables, Etc.

Actuators

Gearheads

Power Supplies

### Power Supplies

- Linear unregulated
- AC input, DC output
- Screw terminal access
- Toroid transformer for lower EMI

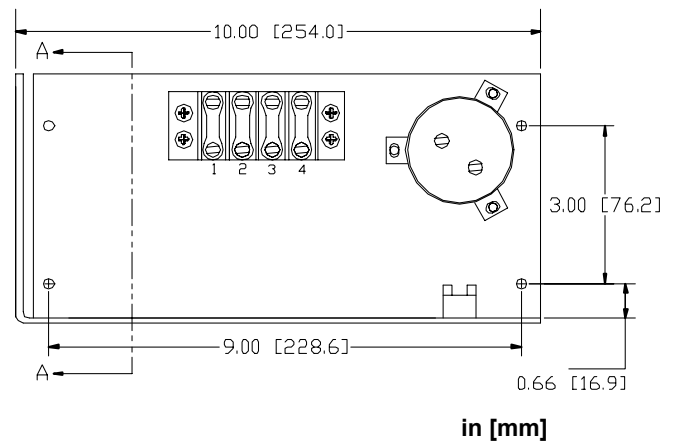
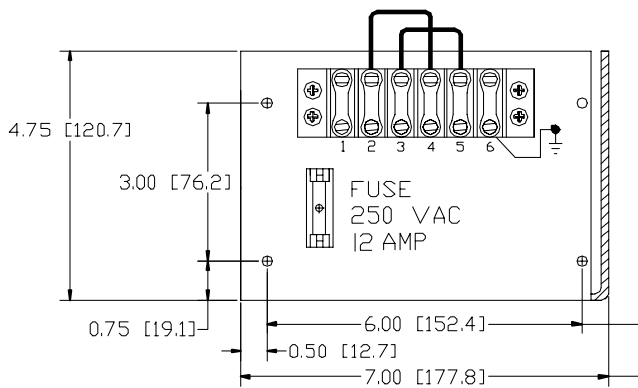
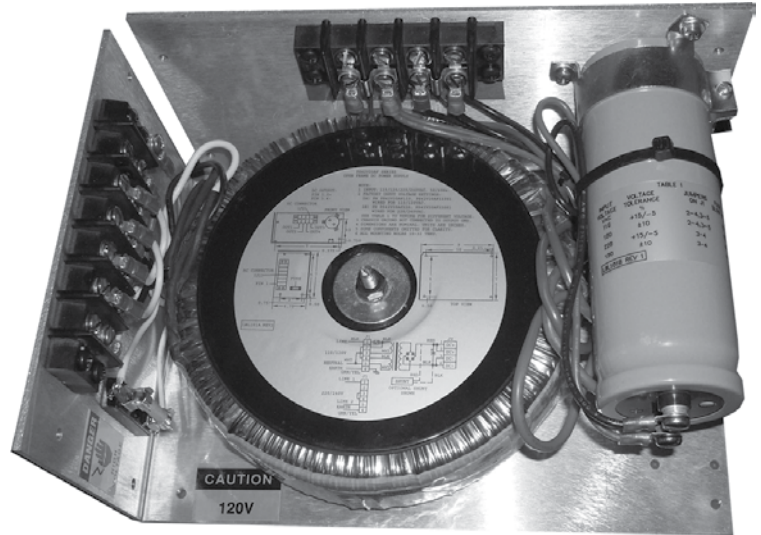

in [mm]

Part Number	Input Voltage and Frequency	No Load Output Voltage	Full Load Output		Nominal Wattage	Shunt	Weight (Nom.)
			Voltage	Current			
PS42V20AF110	120 VAC 50 / 60 Hz	44 VDC	35 VDC	20 Amps	680 W		16.5 lbs (7.5 kg)
PS42V20AF220	240 VAC 50 / 60 Hz	44 VDC	35 VDC	20 Amps	680 W		16.5 lbs (7.5 kg)
PS42V20AF110-S1	120 VAC 50 / 60 Hz	44 VDC	35 VDC	20 Amps	680 W	100 W	17 lbs (7.7 kg)
PS42V20AF220-S1	240 VAC 50 / 60 Hz	44 VDC	35 VDC	20 Amps	680 W	100 W	17 lbs (7.7 kg)
PS42V20AF110-S2	120 VAC 50 / 60 Hz	44 VDC	35 VDC	20 Amps	680 W	200 W	17 lbs (7.7 kg)
PS42V20AF220-S2	240 VAC 50 / 60 Hz	44 VDC	35 VDC	20 Amps	680 W	200 W	17 lbs (7.7 kg)

**⚠ WARNING: Improper power supply sizing may result in motor position error faults, motor resets, and machine faults.**

Overview  
Software  
C5 D-Style  
C5 M-Style  
C6 M-Style  
C6 Low-Cost  
Cables, Etc.  
Actuators  
Gearheads  
Power Supplies

Part Number		PFC500W-48R2	PFC1500W-48
		<ul style="list-style-type: none"> <li>• Universal AC input/full range</li> <li>• Built-in active PFC function, PF&gt;0.95</li> <li>• Protections: short circuit/overload/overvoltage/overtemperature</li> <li>• Forced-air cooling by built-in DC fan with ON/OFF control</li> <li>• Built-in remote ON/OFF control</li> <li>• Built-in remote sense function</li> </ul>	
Output	DC Voltage	48 V	48 V
	Rated Current	10.5 A	32 A
	Rated Power	504 W	1536 W
	Setup, Rise Time	1500 ms, 80 ms at full load	1500 ms, 100 ms at full load
Input	Voltage Range	88 – 264 VAC; 124 – 370 VDC	
	Frequency Range	47 – 63 Hz	
	Power Factor	PF>0.95 / 230 VAC PF>0.98 / 115 VAC at full load	
	Efficiency	90.5%	91%
	AC Current	5.3 A / 115 VAC 2.65 A / 230 VAC	17 A / 115 VAC 8 A / 230 VAC
Protection	Overload	105 – 130% rated power output	105 – 135% rated power output
	Overvoltage	58.4 – 68 V	57.6 – 67.2 V
	Overtemperature	Shut down o/p voltage, recovers automatically after temperature goes down	
Function	Working Temperature	-30 – +70°C	-10 – +50°C
	Working Humidity	20 – 90% RH non-condensing	
Environment	Storage Temperature	-40 – +85°C	
	Storage Humidity	10 – 95% RH	
	Vibration	10 – 500 Hz, 2G 10 min. / cycle, 60 min. each along X,Y,Z axes	
Safety and EMC	Safety Standards	UL60950-1, TUV EN60950-1 approved	
	EMI Conduction and Radiation	Compliance to EN55032 (CISPR32) Class B, EN61000-3-2,-3	Compliance to EN55022 (CISPR22) Class B, EN61000-3-2,-3
	EMS Immunity	Compliance to EN61000-4-2,3,4,5,6,8,11; EN55024, EN61000-6-2, EN61204-3 heavy industry level, criteria A	Compliance to EN61000-4-2,3,4,5,6,8,11; EN55024, EN61204-3, EN61000-6-2
Others	MTBF	187.7K hrs min. MIL-HDBK-217F (25°C)	90.3K hrs min. MIL-HDBK-217F (25°C)
	Dimensions	230 x 127 x 40.5 mm (L x W x H)	278 x 127 x 83.5 mm (L x W x H)
Notes	<ol style="list-style-type: none"> <li>1. All parameters NOT specially mentioned are measured at 230 VAC input, rated load and 25°C of ambient temperature.</li> <li>2. Ripple and noise are measured at 20 MHz of bandwidth by using a 12 inch twisted-pair wire terminated with a 0.1 µf and 47 µf parallel capacitor.</li> <li>3. Tolerance: includes setup tolerance, line regulation, and load regulation.</li> <li>4. The power supply is considered a component that will be installed into the final equipment. The final equipment must be reconfirmed that it still meets EMC directives.</li> <li>5. Derating may be needed under low input voltages. Please check the derating curve for more details.</li> <li>6. Multiple units may be paralleled for additional power.</li> </ol>		

Please refer to the website for detailed diagrams and for more information.

**⚠ WARNING: Improper power supply sizing may result in motor position error faults, motor resets, and machine faults.**



- Enclosed linear unregulated power supplies
- PC-type with AC power cord
- 4-pin AMP connector on output
- Internally fused on both primary and secondary side
- Toroid transformer for minimal voltage drop and minimal EMI



Includes AC power cord and KITDC1 connector kit.

Part Number	Input Voltage	Hz AC	No Load Voltage	Full Load		Nominal Wattage	Weight (Nom.)
				Voltage	Current		
PS24V8AG-110	110 VAC	60	25 VDC	19 VDC	8 Amps	152 W	6.5 lbs (3 kg)
PS42V6AG-110	110 VAC	60	46 VDC	38.7 VDC	6.5 Amps	251 W	7 lbs (3.2 kg)
PS42V6A-220CE	220 VAC	50-60	46 VDC	38.7 VDC	6.5 Amps	251 W	7 lbs (3.2 kg)

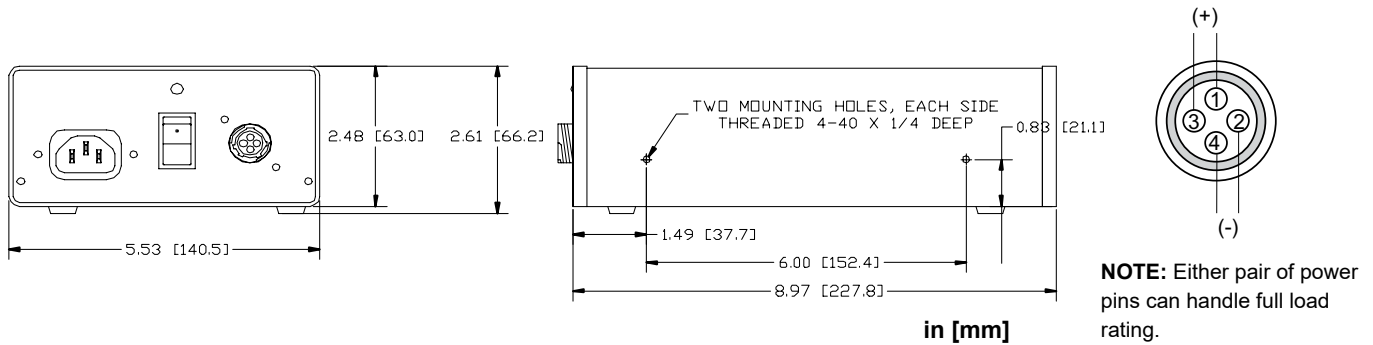

### PWR116V

Enclosed laptop type power supply. This power supply connects directly to:

- CBLSM1-DEMO
- SmartBox™
- SmartBox BCD™

It is ideal for desktop testing of the SmartMotor™ and will easily run an unloaded SmartMotor for programming and evaluation testing.

Input: 100-240 VAC 50 / 60 Hz  
 Output: 24 VDC, 2.5 Amps, 60 Watts  
 Connector Type: 2.1 x 5 mm coax DC power connector  
 Cable Length: ~1 meter

RoHS/CE Certified



### CBLAC1

AC power cable for PWR116V power supply above.  
 Standard 3 prong US AC plug  
 ~1 meter length



**⚠ WARNING: Improper power supply sizing may result in motor position error faults, motor resets, and machine faults.**

Moog Animatics offers several shunt options for use with DC input servo motors. Shunts are needed to protect the servo controller and drive stages from overvoltage.

Overvoltage sources originate from the following:

- Back EMF due to back driving the motors
- Sudden or hard decelerations
- Hard stop crashes (immediate deceleration to zero speed)
- Vertical load drops

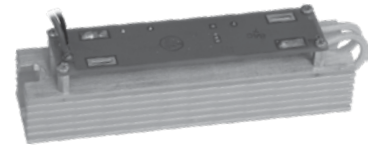

OPEN FRAME SHUNT (300W)

When voltage exceeds the trigger level, the shunts automatically add an additional load to the DC bus by connecting large load resistors across the bus. Trigger voltage is typically 49.5 VDC.

NOTE: Shunts start loading the bus at 49.5 VDC and rising, and will be fully loaded at 53 VDC.

**⚠ WARNING: If the shunt is connected to an adjustable power supply, the output voltage must be set at or below 48 VDC. If the output voltage is sustained above the trip point of the shunt, overheating and damage may result.**

### The Real Story about Back EMF

Generally speaking, back EMF is the voltage generated in a motor when it spins. This voltage is typically proportional to speed. However, this is a general rule. The truth is that the back EMF voltage is proportional to the rate of change of magnetic flux in the windings of the stator. As a result, constant speeds produce constant and predictable voltages. However, sudden changes due to decelerations or hard stop crashes cause an immediate change in magnetic flux or even a total instantaneous collapse. As a result, voltages can go 5 to 10 times higher than spinning the motor at its maximum speed.

For this reason, it is highly recommended to use a shunt in all vertical applications or those where the motors could be quickly stopped or suddenly back driven.

We offer both open frame (100, 200 and 300 Watt) and enclosed (100 and 200 Watt) shunts. The shunts are all automatic and get their power from the DC bus they are attached to. They simply need to be placed in parallel with the DC bus.

NOTE: Shunt PWM control allows load sharing. Multiple shunts may be connected in parallel to handle increased load.

**⚠ WARNING: Shunts should always be placed between the motor input and any disconnect or e-stop relay to ensure protection of the motor when power is not applied or e-stop relay contacts are open.**



ENCLOSED SHUNT 42V

### Open Frame Shunts

- Can be used with power supplies that have an output of 48 VDC or less
- Automatically Gate-On when voltage exceeds trigger voltage
- Easy direct parallel connection to power supply
- SHUNT42V300WOF model offers up to 700W overload capacity for up to 5 sec, and includes a DIN rail adapter for mounting

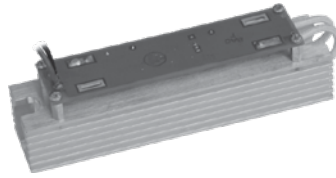

SHUNT42V300WOF

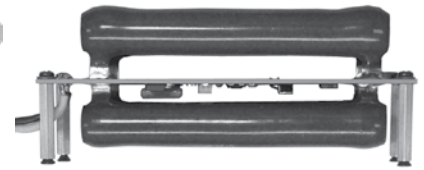

SHUNT42V200WOF

Part Number	Trigger Voltage	Drop Out Voltage	Watts	Effective Bus Load
SHUNT42V100WOF	49.5 VDC Rising	48.5 VDC Falling	100 W	12.5 OHMS
SHUNT42V200WOF	49.5 VDC Rising	48.5 VDC Falling	200 W	6.25 OHMS
SHUNT42V300WOF*	49.5 VDC Rising	48.5 VDC Falling	300 W	4.7 OHMS

\*Available with a convenient DIN rail adapter

### Enclosed Shunts

- Enclosed shunt
- Matching 4-pin AMP connector to enclosed power supply
- Automatically gate on at >=49.5 VDC
- Powered from DC bus
- May be connected in parallel with any supply <=48 VDC



SHUNT42V

Part Number	Trigger Voltage	Drop Out Voltage	Watts	Effective Bus Load
SHUNT42V100W	49.5 VDC Rising	48.5 VDC Falling	100 W	12.5 OHMS
SHUNT42V200W	49.5 VDC Rising	48.5 VDC Falling	200 W	6.25 OHMS



CBLDC1

### Power Supply Cables

Part Number	Connection	Cable Type	Connection Types(s)	Length(s)
CBLAC1	AC Line Cord for Power Supply	Power	N/A	6 ft (1.8 m)
CBLDC1	DC Cable for Enclosed Shunt	DC	4-Pin AMP	1.5 ft (0.45 m)
CBLSMYPWR-T	Multiple SM - Power Supply	Y	4 Pin AMP	2 ft (0.61 m)

Specification and information are subject to change without prior notice. Refer to the website, [www.animatics.com](http://www.animatics.com), for the latest information. Moog Animatics and the Moog Animatics logo, SmartMotor and the SmartMotor logo, Combitronic and the Combitronic logo, and SMI are all trademarks of Moog Inc., Animatics. Other trademarks are the property of their respective owners.





# TAKE A CLOSER LOOK

Moog solutions for a wide variety of applications, including medical, office automation, packaging, industrial, aerospace and defense are only a click away. Visit our worldwide web site for more information.

Americas - West  
Moog Animatics  
2581 Leghorn Street  
Mountain View, CA 94043  
United States

Tel: +1 650-960-4215  
[www.animatics.com](http://www.animatics.com)

Americas - East  
Moog Animatics  
1995 NC Hwy 141  
Murphy, NC 28906  
United States

Tel: +1 828-837-5115  
[www.animatics.com](http://www.animatics.com)

Europe  
Moog GmbH  
Allgaeustr. 8a  
87766 Memmingerberg  
Germany

Tel: +49 (0) 8331 98 480-0  
[www.animatics.de](http://www.animatics.de)

Asia  
Moog Animatics  
Kichijoji Nagatani City Plaza 4F  
1-20-1, Kichijojihoncho  
Musashino-Shi, Tokyo 180-0004  
Japan

Tel: +81 (0) 422 201251  
[www.animatics.jp](http://www.animatics.jp)

For product information, visit [www.animatics.com](http://www.animatics.com)

For more information or the office nearest you, contact us online, [animatics\\_sales@moog.com](mailto:animatics_sales@moog.com)

Moog is a registered trademark of Moog Inc. and its subsidiaries.  
All trademarks as indicated herein are the property of Moog Inc. and its subsidiaries.  
©2019 Moog Inc. All rights reserved. All changes are reserved.

Integrated Motion Control Solutions Product Catalog  
MA1030-0320