

CLASS 6 D-STYLE SMARTMOTOR™

High Power in a Small Package

Fully integrated controller with small footprint, great power density and a simplicity of design hard to match on the market.



The drive to improve the performance of its SmartMotor™, while minimizing footprint, sets Moog Animatics apart from its competitors, reinforcing its position as the industry leading provider of fully integrated motors with motion control capabilities.

The Class 6 D-Style SmartMotor™ offer an extended power range (up to 1 kW) in the same compact package of previous series, provides improved torque density and increased performance without affecting the overall design of the machine.

These enhanced capabilities are combined with industrial Ethernet connectivity and a multi-turn absolute encoder enabling extreme design flexibility for any application.

Features:

- Absolute multi-turn battery-less encoder
- Wider ambient operating temperature range (-20° to 105° C)
- Industry standard 24 VDC I/O
- Separate 24 V Supply for Logic backup
- Communications via RS-232 and CAN over the 7W2 power connector enabling single cable control
- NEMA 17, 23 and 34 frame sizes
- Inline brake options for all models
- Optional Industrial Ethernet fieldbuses (EtherCAT®, EtherNet/IP™, PROFINET®)
- Easy connection to diagnostics over USB
- Accuracy ±0.2 degrees
- Encoder single turn resolution to user (12-bit) 4,096 count/rev (configurable to 14-bit max)

ADVANTAGES

- Fully integrated, compact motion system
- High noise immunity
- Industry leading power density
- High tuning bandwidth
- Enhanced controls with ability to handle complex applications

APPLICATIONS

- Automated Guided Vehicle (AGV)
- Factory automation
- Medical
- Packaging
- Pan and tilt applications
- Semiconductor wafer handling
- Test and measurement



SPECIFICATIONS

TECHNICAL DATA

	Model	Max P/S Peak Current 24 V / 48 V Amps	Max P/S Continuous Current 24 V / 48 V Amps	Continuous Torque 24 V / 48 V N-m (oz-in)	Peak Torque 24 V / 48 V N-m (oz-in)	Nominal Continuous Power 24 V / 48 V Watts	No Load Speed 24 V / 48 V RPM
NEMA 17	 SM17166D*	TBA	TBA	TBA	TBA	TBA	TBA
	 SM23166D	14 / 9	4 / 5	0.25 (35) / 0.26 (37)	0.58 (83) / 0.51 (73)	71 / 156	4,500 / 9,000
NEMA 23	 SM23166DT	17 / 10	8 / 7	0.64 (91) / 0.62 (88)	1.07 (151) / 1.06 (151)	89 / 201	2,400 / 4,800
	 SM23376DT	15 / 15	5 / 5	0.64 (91) / 0.63 (90)	1.51 (214) / 1.82 (258)	74 / 179	2,000 / 4,000
	 SM23266DT**	17 / 12	11 / 9	0.70 (98) / 0.66 (93)	1.24 (176) / 1.24 (176)	152 / 295	3,200 / 6,500
NEMA 34	 SM34166DT shown with brake	38 / 35	25 / 22	2.36 (334) / 2.29 (324)	4.08 (578) / 3.94 (558)	445 / 793	2,500 / 5,000
	 SM34266DT	45 / 41	31 / 26	3.61 (512) / 3.26 (462)	5.57 (788) / 5.27 (746)	527 / 936	2,000 / 4,000

*NEMA Frame Sizes 17 model will be available soon, contact factory for more information.

**Under re-design. Contact factory for more information.

Note: Encoder single turn default resolution (12-bit) 4,096 count/rev max (14-bit) 16,384 count/rev

SPECIFICATIONS

OUTLINE DRAWINGS

SM23166D

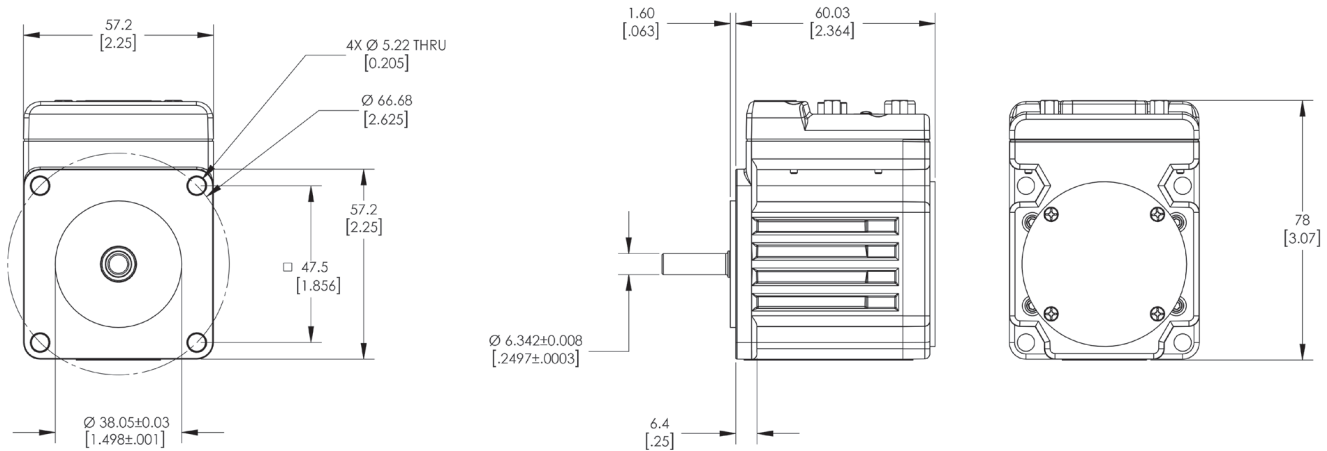

Dimensions in mm [inches]

SM23166D w/Brake

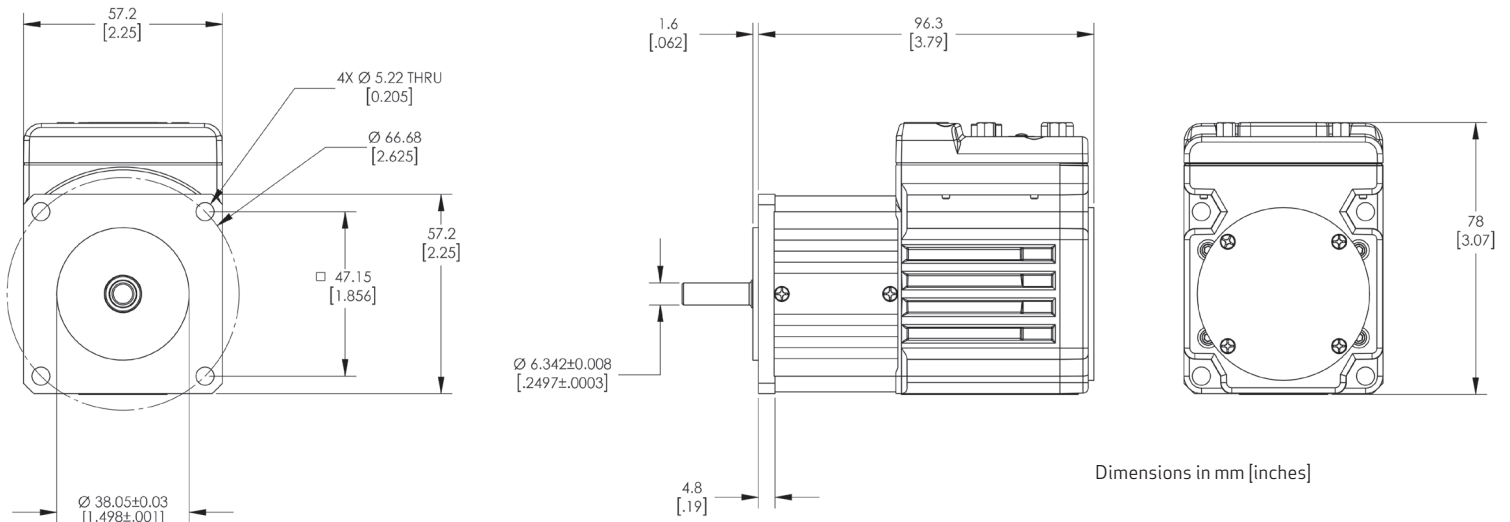

Dimensions in mm [inches]

SM23166DT

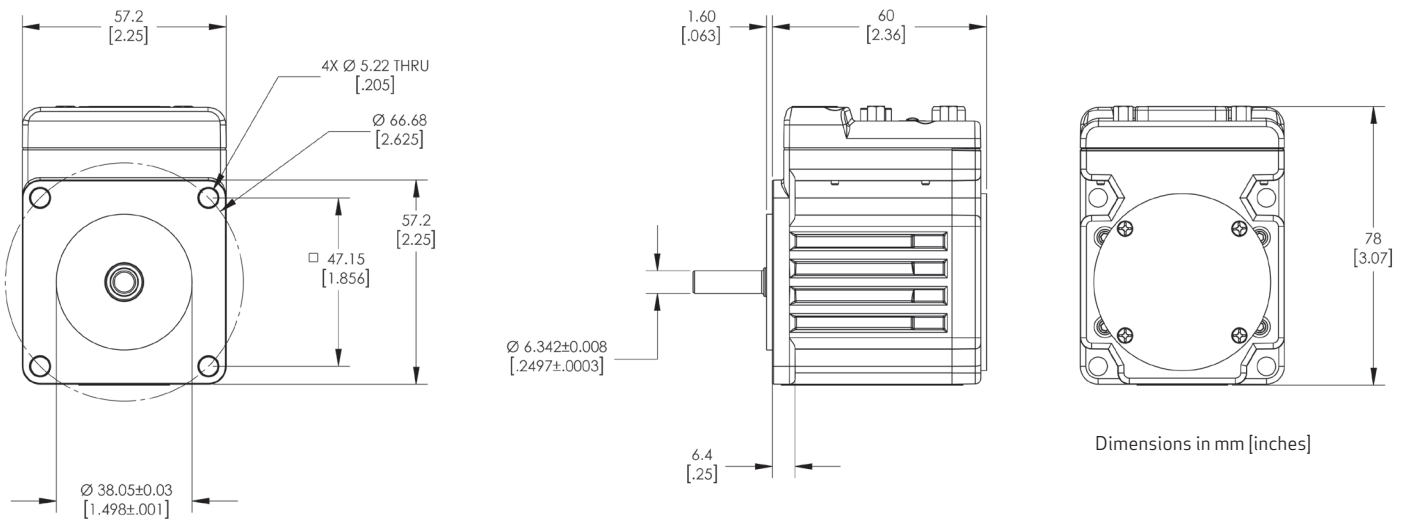

Dimensions in mm [inches]

NOTE: Motor specifications are subject to changes without notice. Consult website and factory for latest data.

SPECIFICATIONS

OUTLINE DRAWINGS

SM23166DT w/Brake

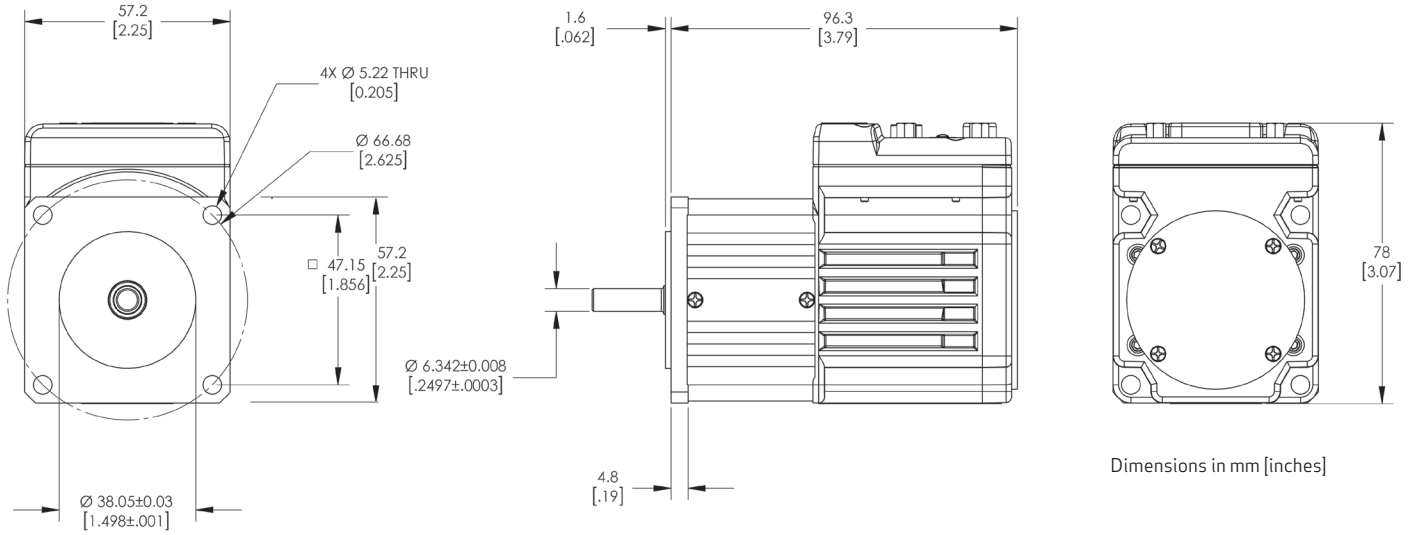

SM23376DT/SM23376DT w/Brake

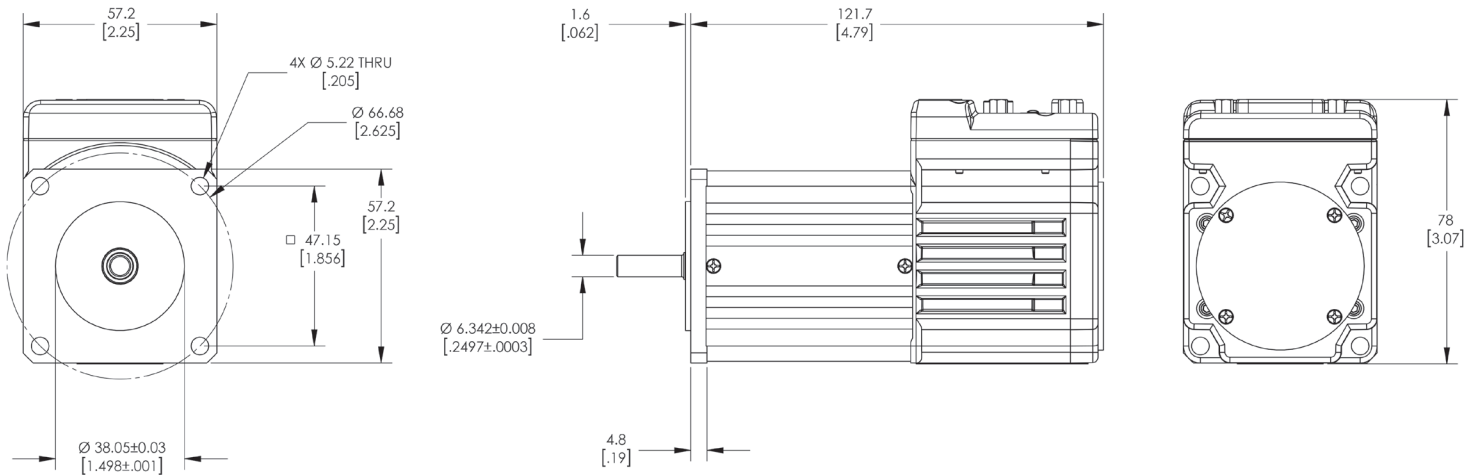

SM23266DT/SM23266DT w/Brake

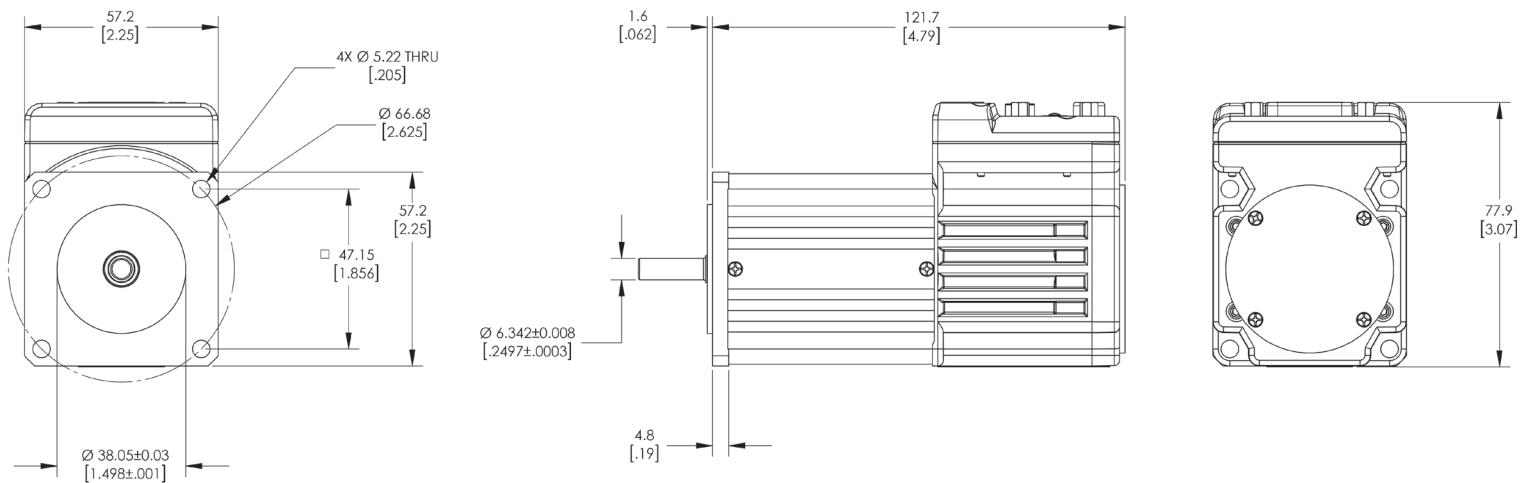

NOTE: Motor specifications are subject to changes without notice. Consult website and factory for latest data.

SPECIFICATIONS

OUTLINE DRAWINGS

SM17166D*

*Check with factory for availability

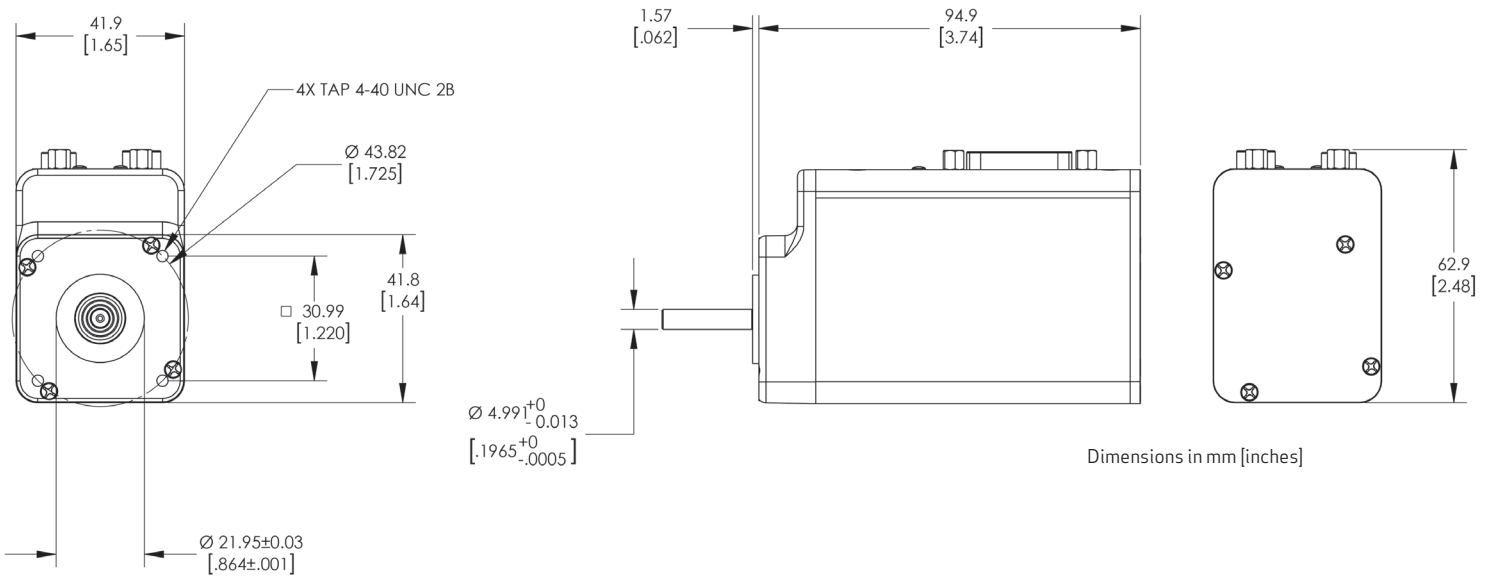

SM34166DT

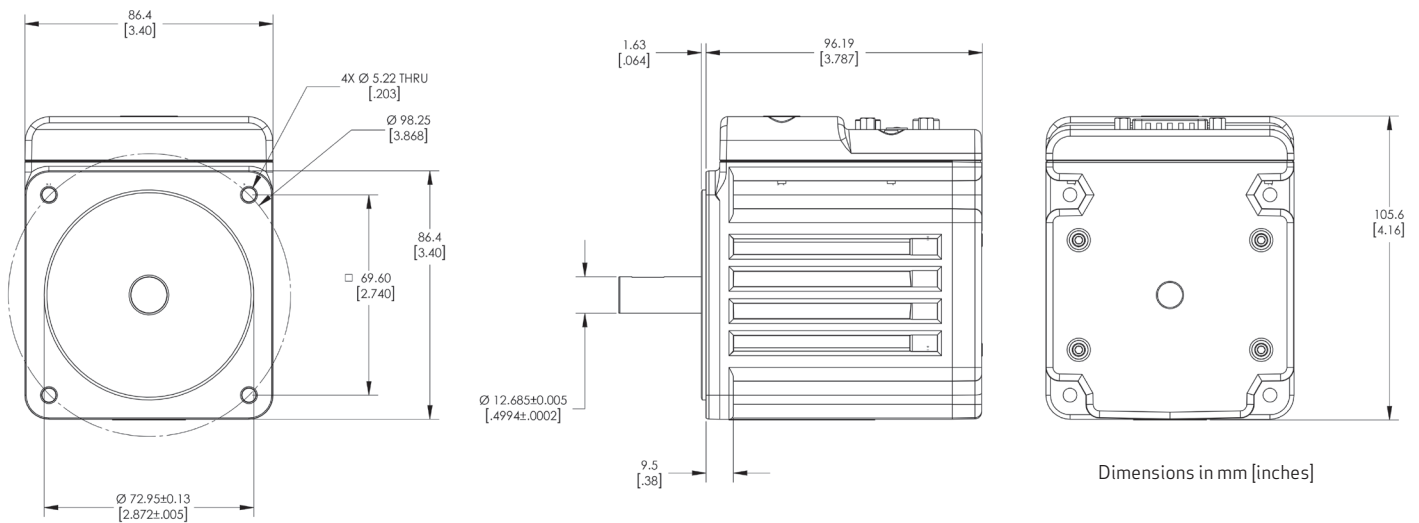

SM34166DT w/Brake

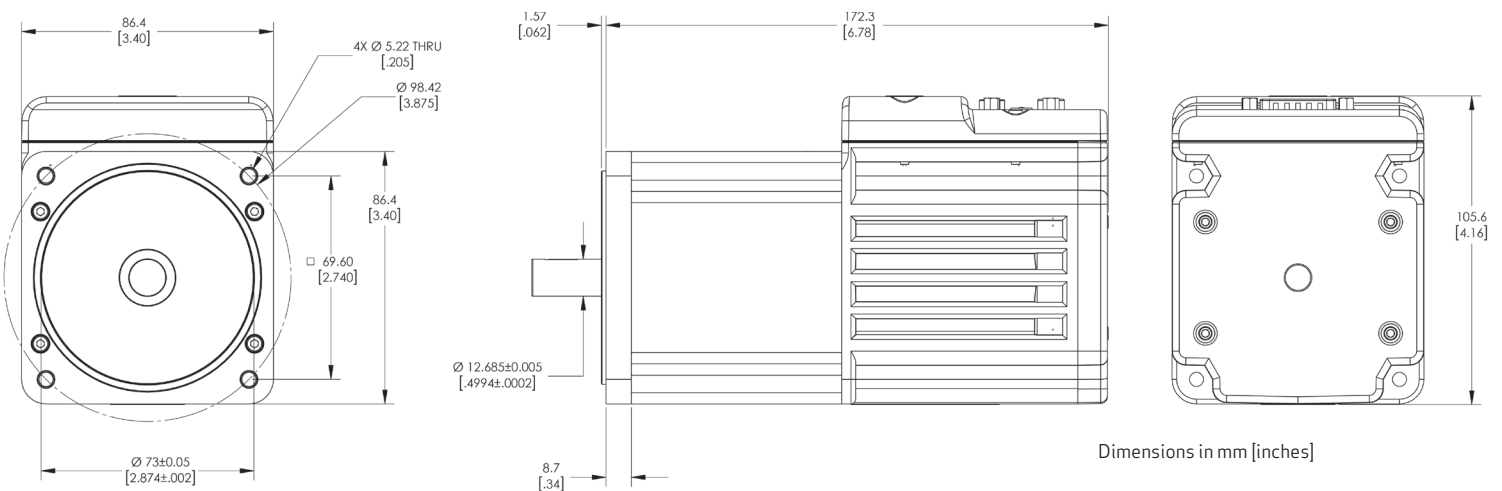

NOTE: Motor specifications are subject to changes without notice. Consult website and factory for latest data.

SPECIFICATIONS

OUTLINE DRAWINGS

SM34266DT

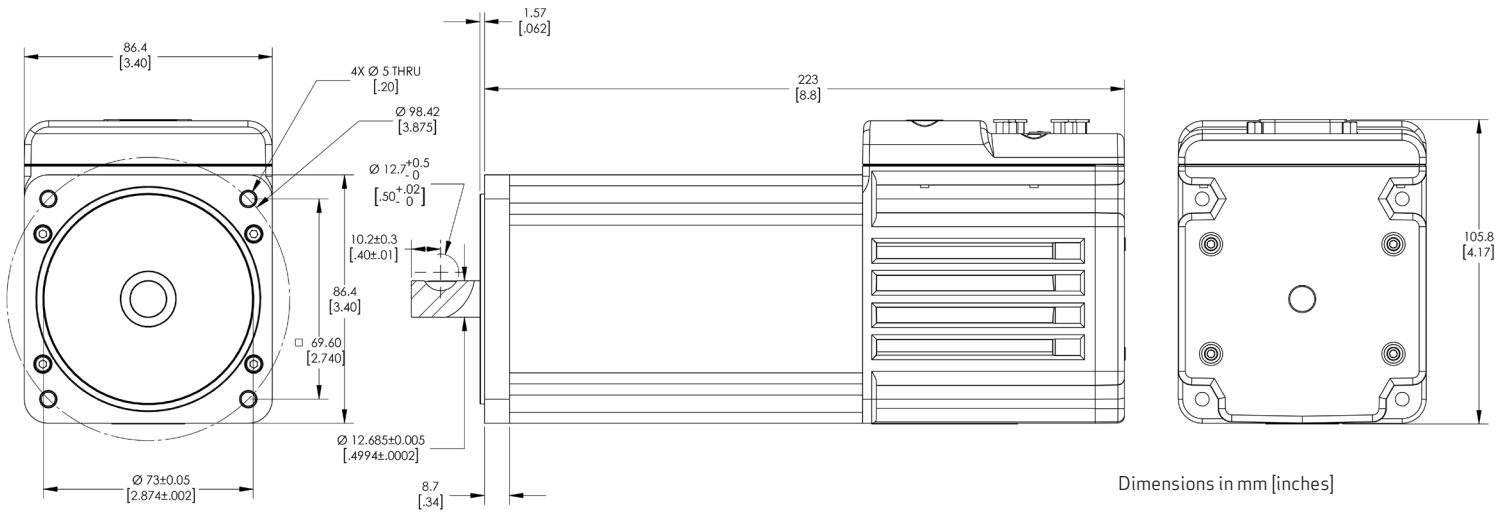

NOTE: Motor specifications are subject to changes without notice. Consult website and factory for latest data.

SPECIFICATIONS

PERFORMANCE TORQUE POWER CURVES AND TECHNICAL DATA

SM23166D at 24 V at Rise from 25° to 105° C

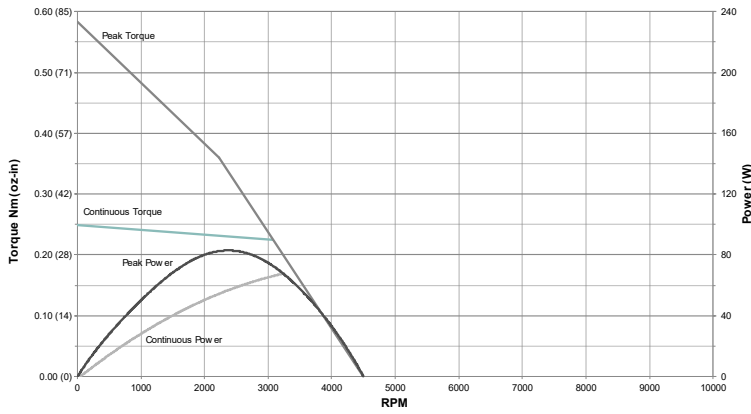

SM23166D at 48 V at Rise from 25° to 105° C

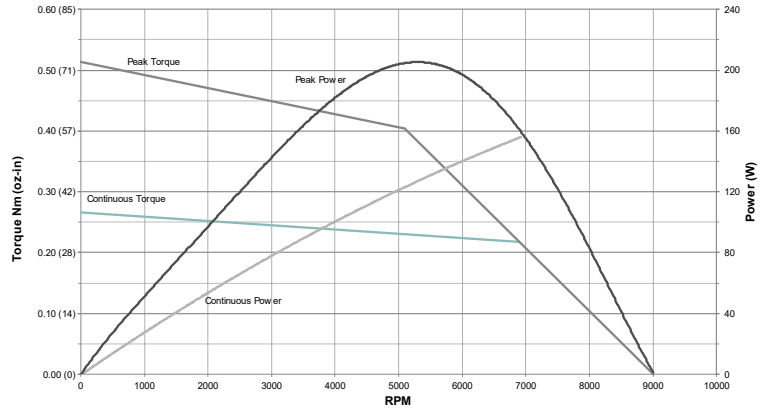

SM23166DT at 24 V at Rise from 25° to 105° C

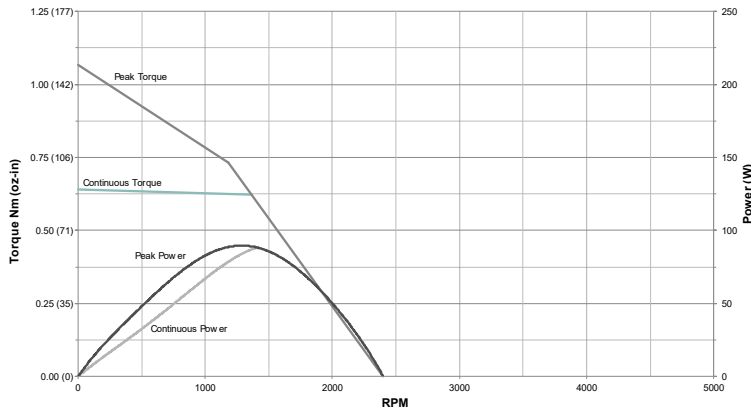

SM23166DT at 48 V at Rise from 25° to 105° C

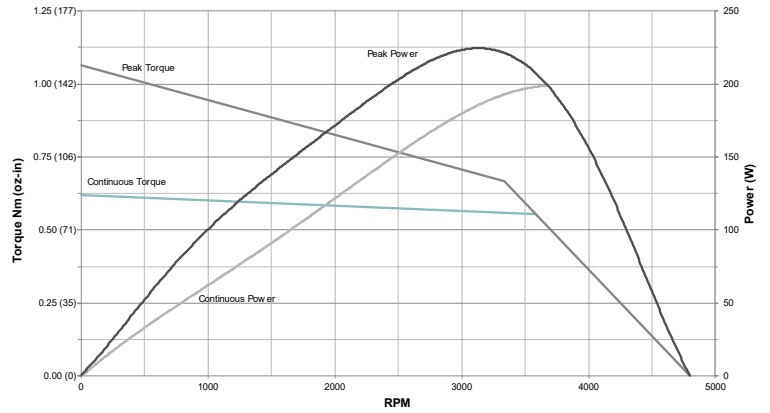

SM23376DT at 24 V at rise from 25° to 105° C

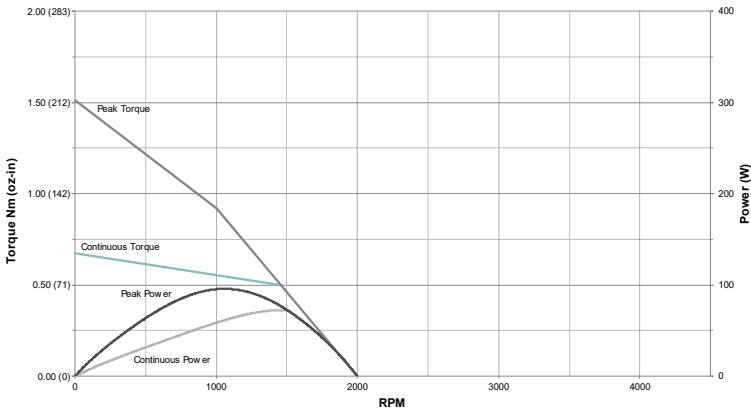

SM23376DT at 48 V at rise from 25° to 105° C

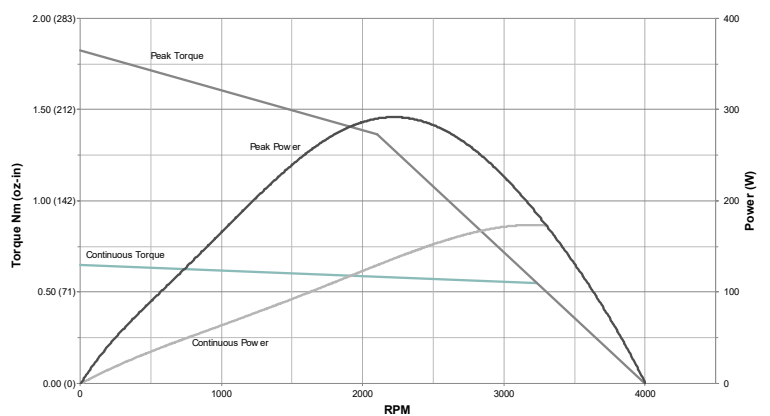

All torque curves based on 25° C ambient. For ambient temperatures above 25° C, continuous torque must be linearly derated to 0% at 105° C. Operating temperature range: from -20 to 105° C. Storage temperature range: from -40 to 125° C. Relative humidity: < 85%, noncondensing. Motors were operated using MDE (Enhanced Trapezoidal Drive Mode) commutation.

SPECIFICATIONS

PERFORMANCE TORQUE POWER CURVES AND TECHNICAL DATA

SM23266DT at 24 V at Rise from 25° to 105° C

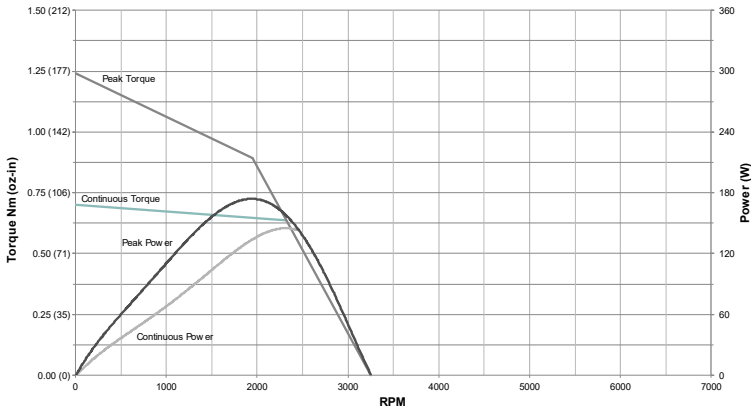

SM23266DT at 48 V at Rise from 25° to 105° C

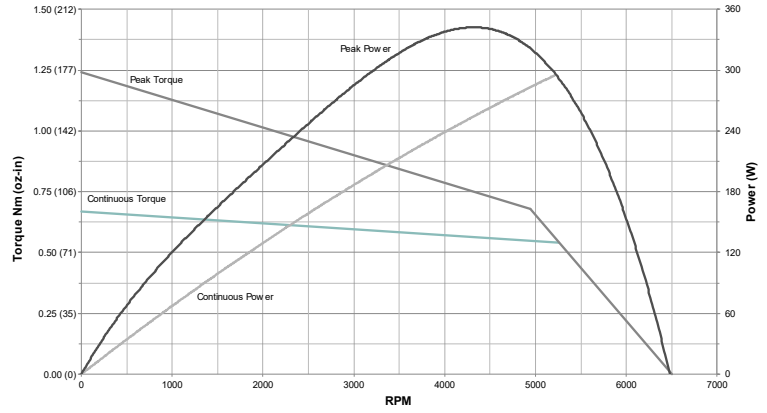

SM34166DT-BRK at 24 V at Rise from 25° to 105° C

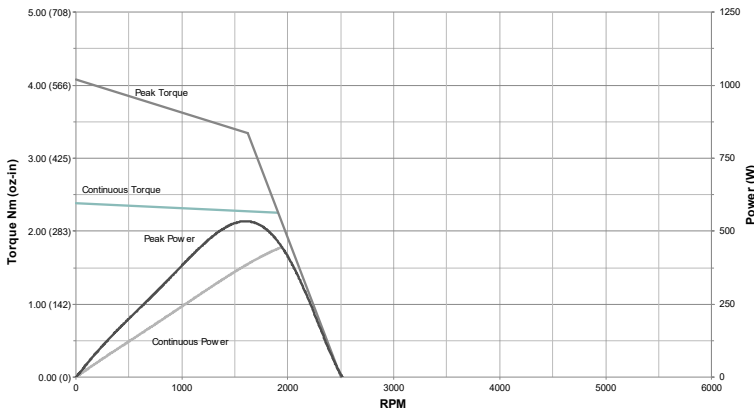

SM34166DT-BRK at 48 V at Rise from 25° to 105° C

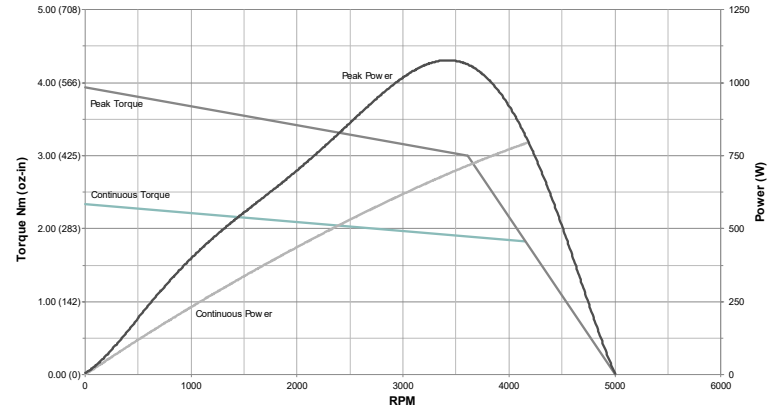

SM34266DT-BRK at 24 V at Rise from 25° to 105° C

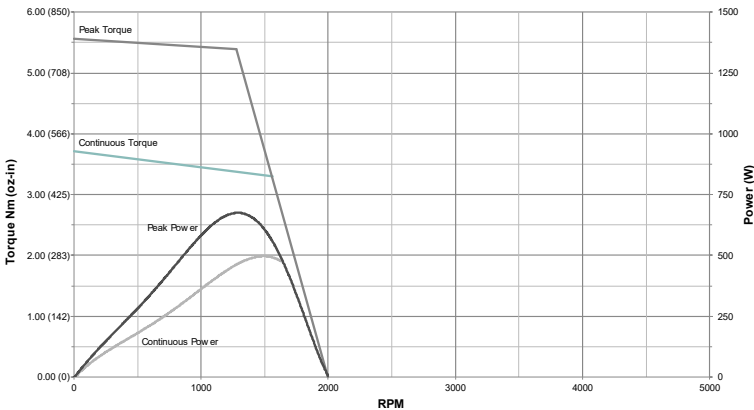

SM34266DT-BRK at 48 V at Rise from 25° to 105° C

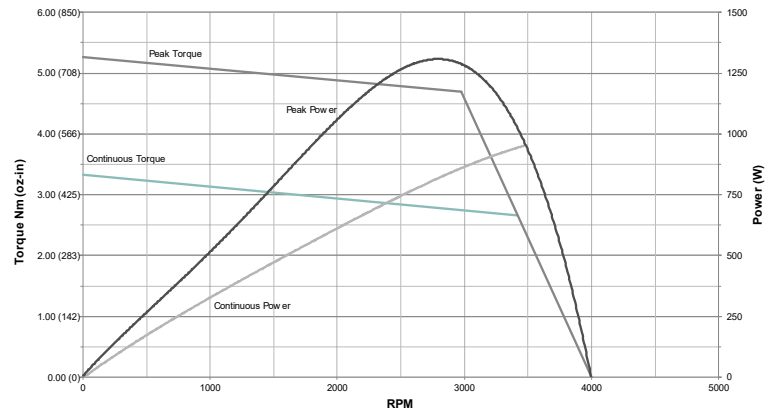

All torque curves based on 25° C ambient. For ambient temperatures above 25° C, continuous torque must be linearly derated to 0% at 105° C. Operating temperature range: from -20 to 105° C. Storage temperature range: from -40 to 125° C. Relative humidity: < 85%, noncondensing. Motors were operated using MDE (Enhanced Trapezoidal Drive Mode) commutation.

OPTIONS

	Options	Available
	Industrial Ethernet	2 Ethernet connections on back of the motor
	Fieldbus protocols	EtherNet/IP™ PROFINET® EtherCAT®
	Brake	Inline
	Standard on all models	DMX protocol Dual power (ability to power controller and drive separately) CANopen per CIA402 Combitronic™ communications over CANopen or EtherNet/IP™ CAN over D-Sub 7W2 (CDS7) MODBUS RTU MODBUS TCP (standard with EtherNet/IP™) Ethernet Serial Encapsulation (standard with EtherNet/IP™)

ETHERNET OPTION

For all motors with Ethernet connectors, add the dimensions of the following module on the back, to the overall mechanical dimensions:

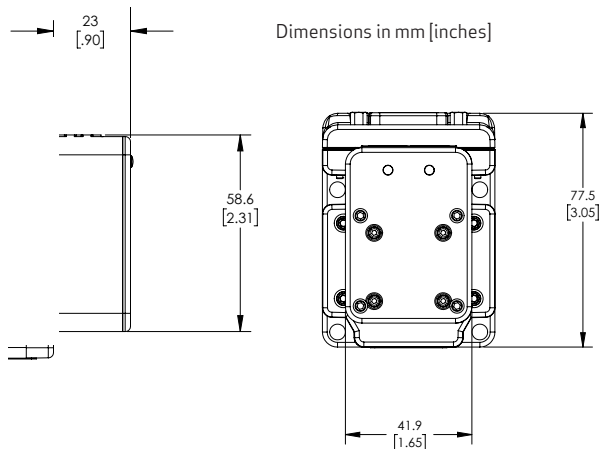

DUAL POWER

Standard feature, provides the ability to power the entire motor from one supply or use separate supplies for the drive and controller.

Single Power Supply

Powers Drive and Controller

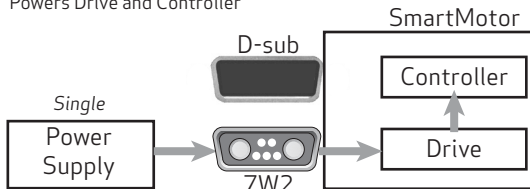

Dual Power Supplies

Maintains Controller if Drive Power is Cut

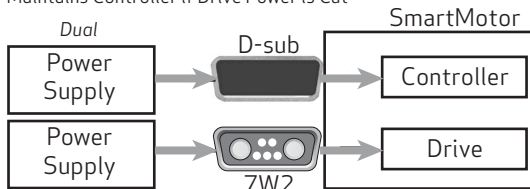

CONNECTORS

HD26-Pin D-Sub I/O

Top row: 9 8 7 6 5 4 3 2 1
Mid row: 18 17 16 15 14 13 12 11 10

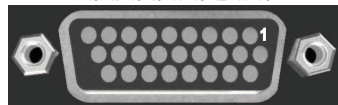

Bottom row: 26 25 24 23 22 21 20 19

Pin	Description	Pin	Description
1	IN0 GP, also Analog Input	14	Encoder A- Input
2	IN1 GP, also Analog Input	15	Encoder B+ Input
3	IN2 Positive Limit or GP	16	Encoder B- Input
4	IN3 Negative Limit or GP	17	CAN High (Also on 7W2)
5	IN/OUT4 GP or Ext. Enc. Index Capture	18	CAN Low (Also on 7W2)
6	IN/OUT5 GP or Int. Enc. Index Capture	19	RS-485 B (COM CH 1)
7	IN6, G CMD, Homing Input	20	RS-485 A (COM CH 1)
8	IN7, Drive Enable Input (Dedicated)	21	4-20 mA Send
9	IN/OUT8, GP or Brake Line Out	22	4-20 mA Return
10	IN/OUT9, GP or Not Fault Out	23	USB +5 V Bus
11	+24 VDC Control Power	24	USB D+
12	Control Power Rtn (Ground, Common)	25	USB D-
13	Encoder A+ Input	26	Ground, Common

7-Pin Combo D-Sub Power and I/O

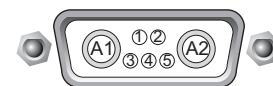

Pin	Description
A1	Main Power +20 - 48 VDC
A2	Common Ground (Req'd. POWER Ground)
1	CAN Low (Also on HD26)
2	CAN High (Also on HD26)
3	RS-232 Transmit (COM CH 0)
4	RS-232 Receive (COM CH 0)
5	SIG Ground

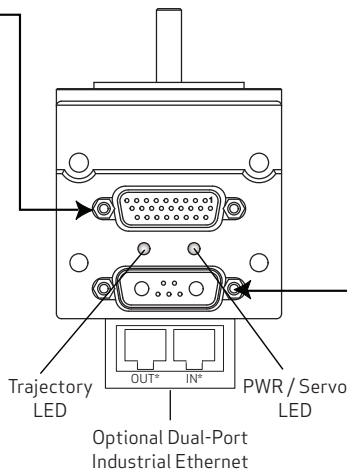

*IN/OUT applies only to EtherCAT® networks.

POWER CABLES AND ADAPTER

Power and Communication Cable (Flying Leads) for Main 7W2 Connector on the SmartMotor™

CBLPWRCOM3 series provides power along with RS-232 and CAN Bus communications in one convenient cable to simplify installation. It consists of a 7W2 main motor connector with RS-232 and CAN communications separately shielded from power, and a full shield over the entire length terminating at a metal jacket inside the over-molded connector.

Part Number	Length
CBLPWRCOM3-5M	5 meters
CBLPWRCOM3-10M	10 meters

NOTE: The connector has a blue cover.

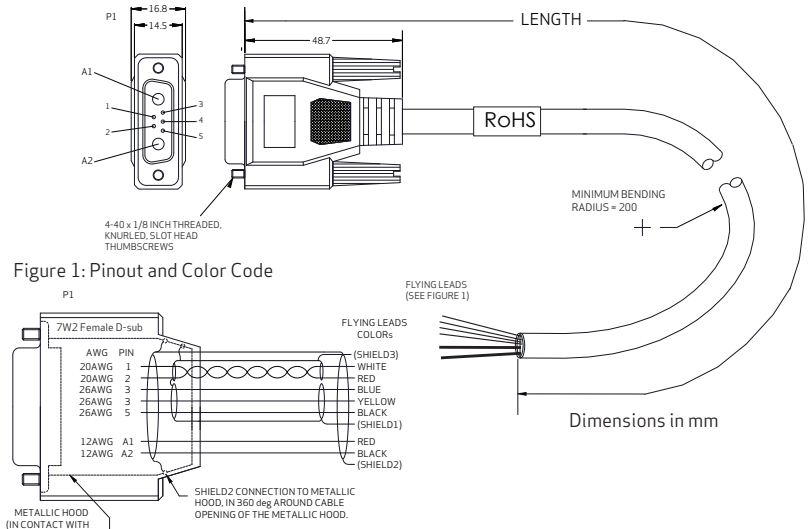

Figure 1: Pinout and Color Code

POWER CABLES AND ADAPTER

CBLSMCDs-xM (Moog Animatics CDS7 "Add-A-Motor" Cable)

Power, RS-232 and CAN Bus Communications Daisy Chain Cable for Single-Cable Connections Between Multiple Moog Animatics SmartMotor™ Servos

CBLSMCDs series is the "Add-A-Motor" -style power and communications cable for a CDS7-equipped SmartMotor. It consists of a pass-thru 7W2 main motor connector split out to a single second motor 7W2 connector. This single cable is capable of carrying power, RS-232 and CAN Bus communications from motor to motor using only the 7W2 connector.

The CBLSMCDs cable is designed to allow ease of connection to multiple motors in a single daisy-chain network. The main power ground wire is a larger gauge to decrease noise emissions at the ground-plane level. All communications lines are internally shielded from the power lines.

The two end nodes of the CAN Bus network must be terminated with a 120 ohm terminator (shunt) for proper biasing. If an end node is a SmartMotor, termination can be achieved using CBLHD26-ASM which has an in built termination resistor.

Part Number	Length
CBLSMCDs-0.3	0.3 meters
CBLSMCDs-0.9	0.9 meters
CBLSMCDs-3.0	3 meters

Figure 1

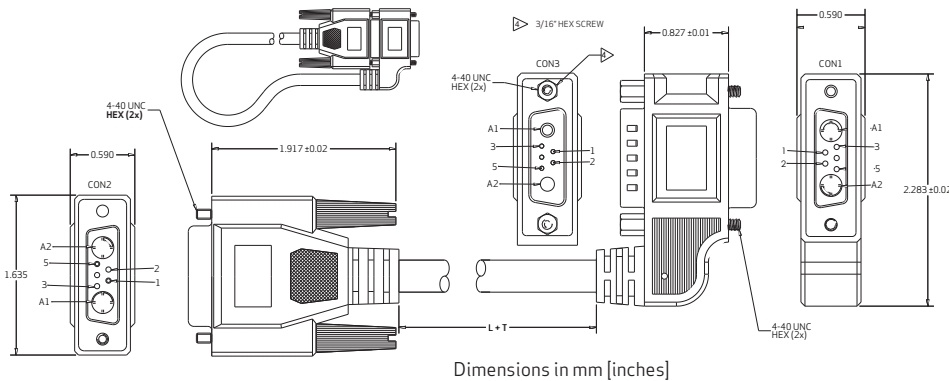
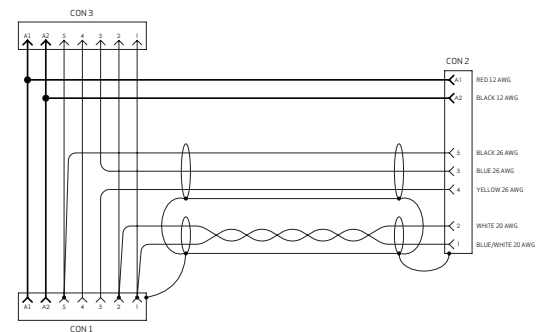

Figure 2



Connector Pinouts

CON 3 Pin	AWG - Color / Stripe	CON 1 Pin	AWG - Color / Stripe	CON 2 Pin	Description
1	20 - Any	1	20 - Blue/White	1	CAN Bus Low
2	20 - Any	2	20 - White	2	CAN Bus High
3		NC	26 - Blue	3	RS-232 TX
NC		3	26 - Yellow	4	RS-232 Crossover
4	26 - Any	4		NC	RS-232 RX
5	26 - Any	5	26 - Black	5	Signal Return
A1	12 - Any	A1	*12 - Red	A1	Power
A2	12 - Any	A2	*12 - Black	A2	Ground

*CON 2 PIN A1 and A2 wires spliced to wires between CON 1 and 3.

Terminate 20/26 AWG shield drain wires to CON 1 and CON 2 as shown in Figure 2.

CAUTION: When using these cables with the larger 34 frame motors, please consult the factory for power limitations.

I/O ADAPTER

HD26 Cable Connector (PN: CBLHD26-ASM)

Part CBLHD26-ASM is available so that users can construct their own interface cable for the Class 6 D-style SmartMotor. The connector (with customer-supplied cable) attaches to the HD26 D-sub connector on the motor. The figure and table show the PCB connection points for the customer-supplied cable. A Micro USB port provides a convenient access point for programming from SMI.

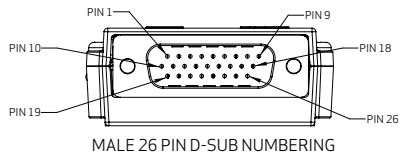

Part Number	Length
CBLHD26-ASM	Connector w/PCB

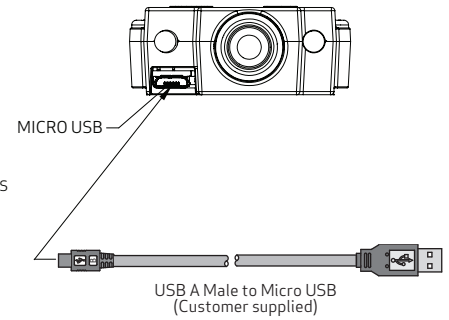
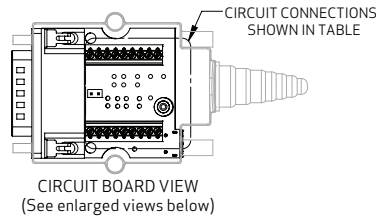
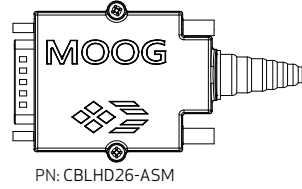

Connector Pinouts			
Pin	Description	PCB	AWG
1	IN0 GP, also Analog Input	I0	26
2	IN1 GP, also Analog Input	I1	26
3	IN2 Positive Limit or GP	I2	26
4	IN3 Negative Limit or GP	I3	26
5	IN/OUT4 GP or Ext. Enc. Index Capture	I04	26
6	IN/OUT5 GP or Int. Enc. Index Capture	I05	26
7	IN6 GP, G Command or Homing Input	I6	26
8	IN7 Drive Enable Input (Dedicated)	I7	26
9	IN/OUT8 GP or Brake Line Output	I08	26
10	IN/OUT9 GP or Not Fault Output	I09	26
11	+24 VDC Control Power	24 V	18
12	Control Power Return (Ground, Common)	RTN	18
13	Encoder A+ Input	A+	26
14	Encoder A- Input	A-	26
15	Encoder B+ Input	B+	26
16	Encoder B- Input	B-	26
17	CAN High (also on 7W2)	C_P	18
18	CAN Low (also on 7W2)	C_N	18
19	RS-485 B (COM CH 1)	RS485B	26
20	RS-485 A (COM CH 1)	RS485A	26
21	4 - 20 mA Send	4-20S	26
22	4 - 20 mA Return	4-20R	26
23	USB +5 V Bus	-	-
24	USB D +	-	-
25	USB D -	-	-
26	Ground, Common	-	-
-	Ground, Common	RTN	-
-	Shield	SH	-
-	Jumper - CAN 120 Ohm Term ON if Start/End CAN Node	CAN TERM	-

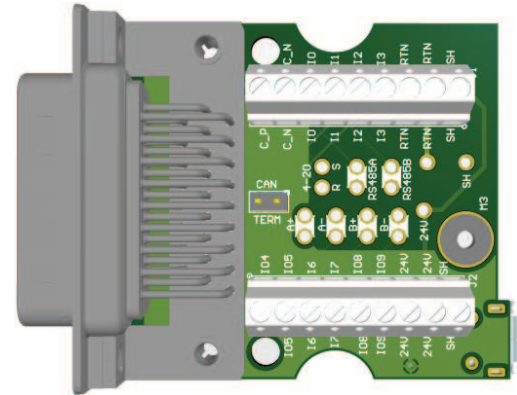
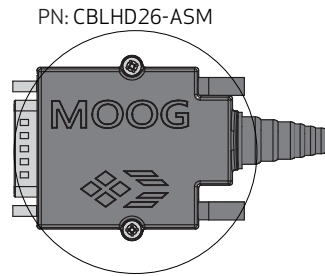

NOTES: Screw connections are provided for most commonly used signals.

Recommended wire gauge sizes for all screw terminal connections:

- 18 gauge for Control power (+24 V and RTN)
- 18 gauge twisted pair shielded for CAN High and CAN Low (CAN-P and CAN-N)
- 26 gauge for any I/O, not to exceed 200 mA for any single channel output

Recommended wire gauge sizes for solder pad connections:

- 26 gauge twisted pair shielded for RS-485 (RS-485A and RS-485B)
- 26 gauge twisted pair shielded for each A and B encoder input (A+ / A-, B+ / B-)
- 26 gauge pair for 4-20 mA Analog input

While it is expected that users will develop their own interface cables based on application needs, Moog can supply cable wire at specified lengths. Please contact the factory for more information.

Extra power connection points are provided for +24 V and RTN through screw terminals and solder pads; these are for use with local sensors and travel limits.

Shield drain wire connections should be terminated only on one end of any shielded cable used.

The shield connection to this board terminates to the HD26 connector shell only. When plugged into the motor, the connector shell will connect to the motor chassis only; it is not (and should never be) connected to either the drive or control power return lines.

A USB connection is only allowed through the included Micro USB port; there is no other external access on this adapter. The USB port is used to program from SMI; it is not recommended for running the motor.

PART NUMBERING GUIDELINES

ORDERING CODE

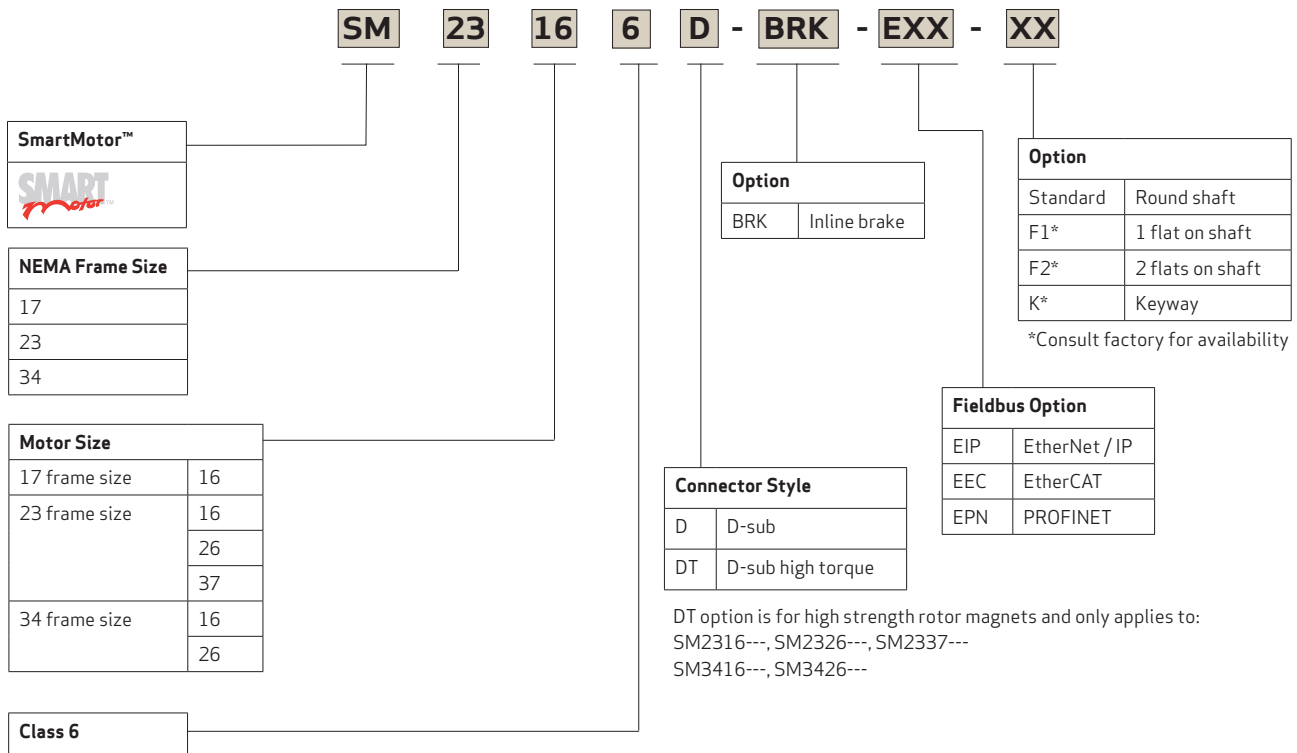

For product information, visit www.animatics.com

For more information or the office nearest you, contact us online, animatics_sales@moog.com

Moog is a registered trademark of Moog Inc. and its subsidiaries.
All trademarks as indicated herein are the property of Moog Inc. and its subsidiaries.
©2023 Moog Inc. All rights reserved. All changes are reserved.

Moog Animatics Class 6 D-Style SmartMotor™ Technical Data Sheet
MCM/Rev. G, May 2023, Id. CDL65512-en