

NOTES: BRAKE HOLDING TORQUE: 45 OZ-IN (0.32 N-m)  
BRAKE IS NORMALLY ON (UNTIL COMMANDED TO RELEASE).

THE BRAKE HAS ITS OWN INTERNAL VOLTAGE REGULATOR, SO THE VOLTAGE INPUT RATING OF THE MOTOR REMAINS THE SAME, 24 TO 48 VDC.

RELATED COMMANDS:  
BRKENG BRAKE ENGAGE  
BRKRLS BRAKE RELEASE  
BRKSRV RELEASE WHEN SERVOING  
BRKTRJ RELEASE DURING TRAJECTORY

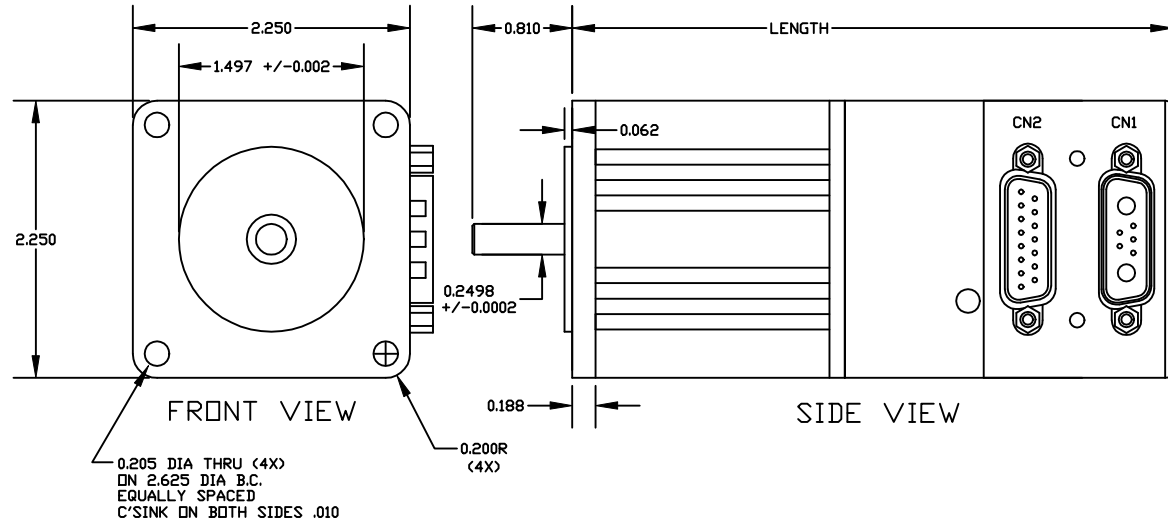

MODEL	LENGTH [INCH]	ROTOR+BRAKE INERTIA [OZ-IN-S <sup>2</sup> ]	WEIGHT [LB]
SM2310D-BRK	4.225	0.00109	1.53
SM2320D-BRK	4.875	0.00199	2.07
SM2330D-BRK	5.525	0.00288	2.60
SM2337D-BRK	5.665	0.00205	2.43
SM2340D-BRK	6.175	0.00377	3.12

CN2: 15 PIN D-SUB FEMALE CONNECTOR					
SOFTWARE SELECTABLE FUNCTIONS					
PIN#	NAME	SPECIAL FUNCTIONS	SPECIAL FUNCTIONS	DIGITAL I/O (TTL)	ANALOG INPUT (10 bit)
1	Port A	External Encoder A Input	Step Input	5V	0 to 5V
2	Port B	External Encoder B Input	Direction Input	5V	0 to 5V
3	Port C	Right Limit Input		5V	0 to 5V
4	Port D	Left Limit Input		5V	0 to 5V
5	Port E	Anlink Data	RS-485 Signal A	5V	0 to 5V
6	Port F	Anlink Clock	RS-485 Signal B	5V	0 to 5V
7	Port G	G-Synchronization Pin	RS-485 Adapter Flow Control Line	5V	0 to 5V
8	ENCA OUT	Encoder A Output			
9	ENCB OUT	Encoder B Output			
10	RS232 TX	RS232-Transmit			
11	RS232 RX	RS232-Receive			
12	+5V OUT	+5V Out			
13	GND	Signal Ground			
14	PWR GND	Power Ground			
15	POWER	Power, +24v to 48v			

CN1: 7 PIN COMBO D-SUB MALE CONNECTOR		
PIN#	NAME	FUNCTIONS
1	Port G	G-Synchronization Pin
2	+5V OUT	+5V Out
3	RS232 TX	RS232-Transmit
4	RS232 RX	RS232-Receive
5	GND	Signal Ground
A1	POWER	Power, +24v to 48v
A2	PWR GND	Power Ground

TITLE: SM23XXD-BRK	
REV: 1	MATERIAL:
DATE: 5/23/01	FINISH: BLACK ANODIZE
TOL: XXXXX +/- .005 XXXXX +/- .005 XXXXX +/- .01 INCHES	ANIMATICS CORPORATION 3050 TASMAN DR. SANTA CLARA
UNLESS OTHERWISE NOTED	