

- NOTES:
- DRAWING APPLIES TO THE FOLLOWING SMARTMOTOR WITH PART NUMBERS:  
 SM3416DT-PLS2 SM3416DT-DEPLS2  
 SM34165DT SM34165DT-DE
  - LED, SERVO-AMPLIFIER:
    - FOR SM3416DT-PLS2
      - CLEAR = CONTROLLER POWER NOT AVAILABLE
      - RED = DRIVE (AMPLIFIER) IS OFF
      - GREEN = DRIVE (AMPLIFIER) IS ON
    - FOR SM34165DT
      - CLEAR = CONTROLLER POWER NOT AVAILABLE
      - RED = FAULT
      - FLASH GREEN = DRIVE (AMPLIFIER) IS OFF
      - GREEN = DRIVE (AMPLIFIER) IS ON
  - LED, TRAJECTORY
    - CLEAR = NOT IN CONTROLLED TRAJECTORY (DEFAULT STATE)
    - GREEN = IN CONTROLLED TRAJECTORY (CLOSE LOOP MOTION)
  - FOR -DE OPTION, DRIVE POWER AND CONTROLLER POWER ARE ON SEPARATE PINS. MUST PROVIDE POWER TO CONTROLLER AND DRIVE POWER TO OPERATE. SEE TABLE CN2 BELOW FOR PIN ASSIGNMENT.
  - DIMENSIONS IN [ ] ARE mm.
  - RECOMMENDED BOLTING SCREW SIZE TO BE 10-32 OR M5x0.8.

REV.	DESCRIPTION	ZONE	ECO	DATE	APPROVED
1A	DIMENSIONS EDITED			04/09/2010	M. TRAN

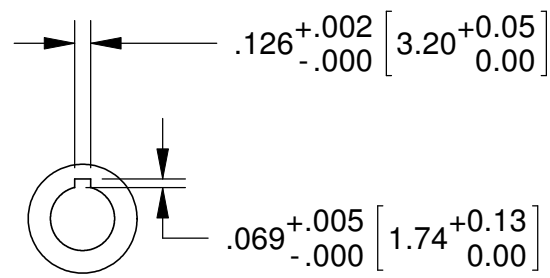
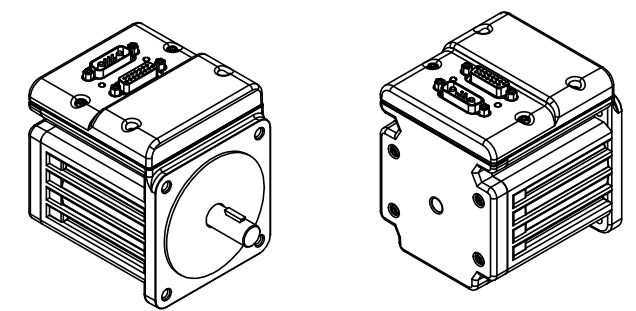

ANSI WOODRUFF  
KEYSEAT HUB  
KEY# 404

ANSI WOODRUFF  
KEY# 404

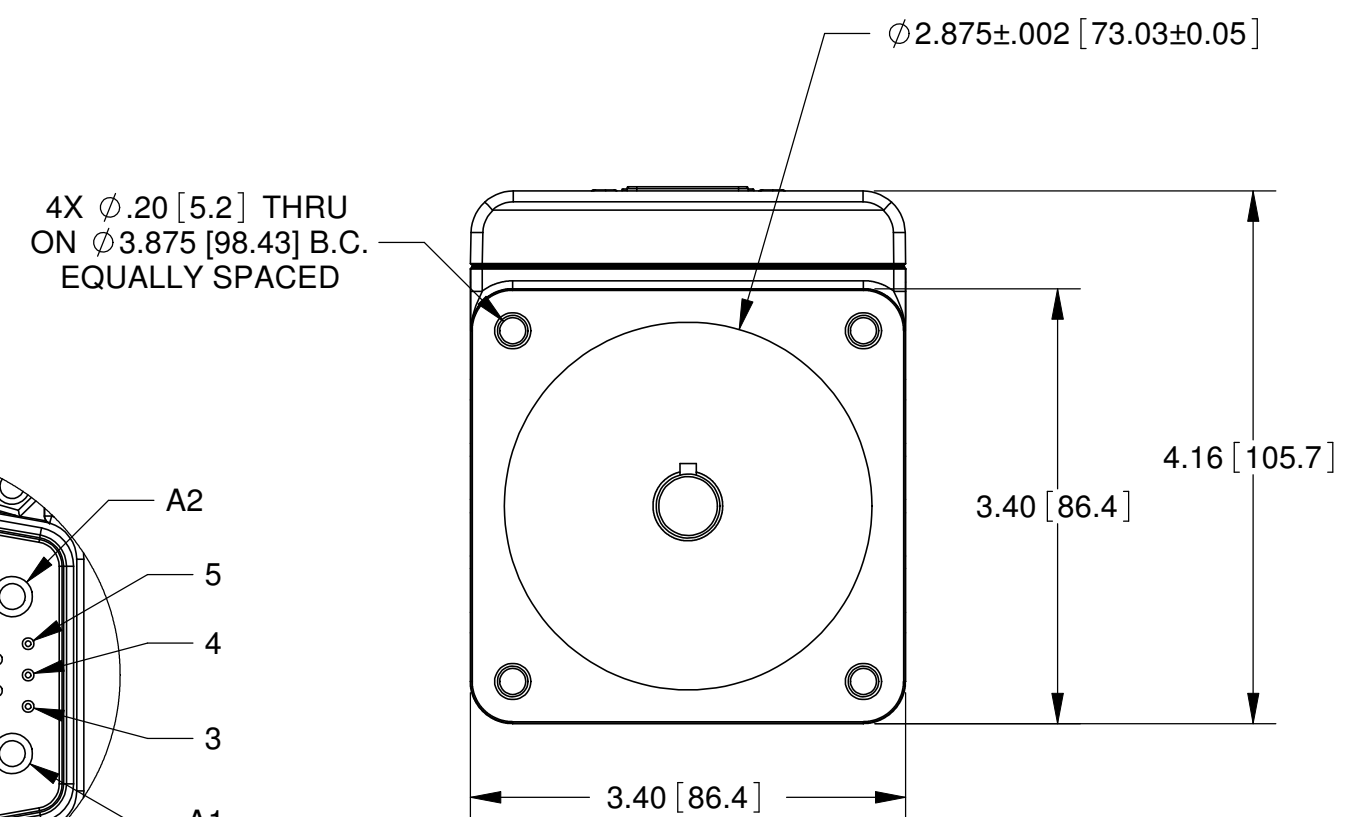
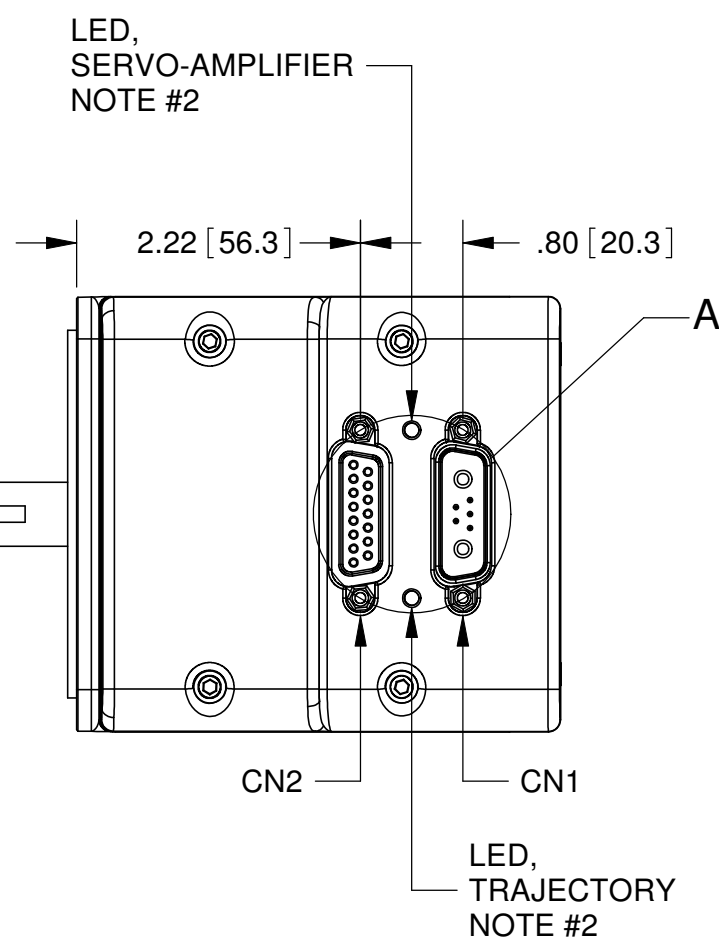

DETAIL A  
SCALE 1.5 : 1

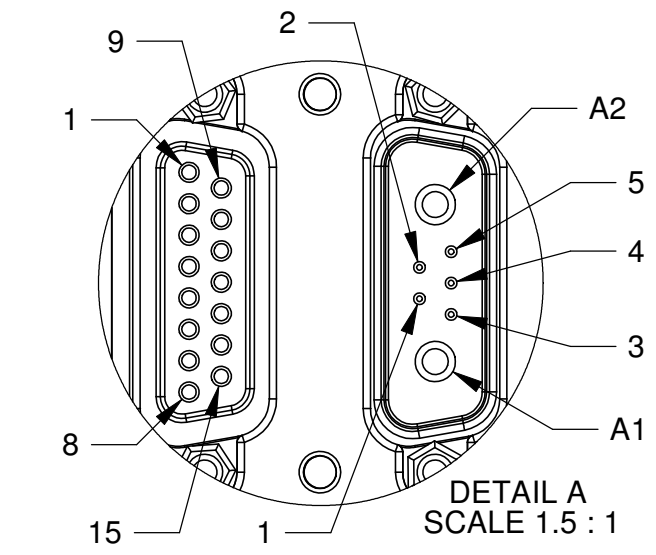
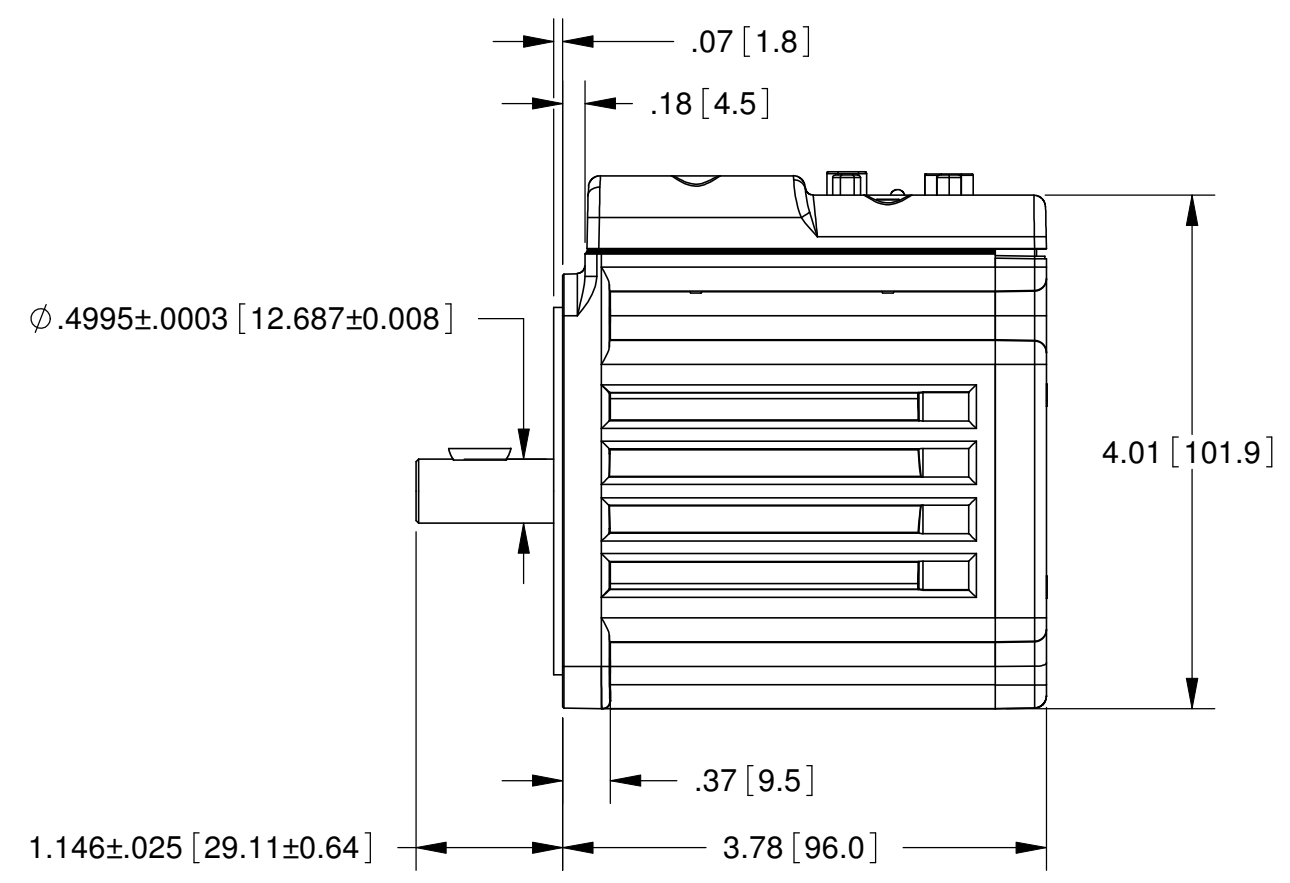

CN2 : 15PIN D-SUB FEMALE CONNECTOR					
PIN #	NAME	FUNCTIONS			
		Default Function	Secondary Function	Digital I/O	Analog Input (10bit Res)
1	I/O A	External Encoder A Input	Step Input	5V TTL	0 to 5V
2	I/O B	External Encoder B Input	Direction Input	5V TTL	0 to 5V
3	I/O C	Positive Limit Input		5V TTL	0 to 5V
4	I/O D	Negative Limit Input		5V TTL	0 to 5V
5	I/O E	AniLink Data *	RS485 A ( Pos )	5V TTL	0 to 5V
6	I/O F	AniLink Clock *	RS485 B ( Neg )	5V TTL	0 to 5V
7	I/O G	G-Synchronization	RS485-ISO Adaptor Data Flow Control	5V TTL	0 to 5V
8	ENC A OUT	Encoder A Output			
9	ENC B OUT	Encoder B Output			
10	RS232 Tx	RS232 Transmit			
11	RS232 Rx	RS232 Receive			
12	+5Vdc OUT	+5Vdc Supply Out			
13	GND	Signal GND			
14	POWER GND	POWER GND			
15	POWER	POWER			

\* NOT AVAILABLE ON SM34165DT

For -DE Option, Pin 15 is Contorl power (20V to 48V) and Pin 14 is PWR GND. \*PIN 15 is not connected to A1.

CN1 : 7PIN COMBO D-Sub Male Connector				
PIN #	NAME	FUNCTIONS	Ties to CN2, PIN #	
1	I/O G	G-Synchronization	7	
2	+5V dc OUT	+5Vdc Output	12	
3	RS232 Tx	RS232 Transmit	10	
4	RS232 Rx	RS232 Received	11	
5	GND	Signal GND	13	
A1	DRIVE PWR	Dirve Power (20 - 48Vdc)	15^	
A2	POWER GND	POWER GND	14	

**CONFIDENTIAL.** THE INFORMATION CONTAINED HEREIN IS THE PROPRIETY PROPERTY OF ANIMATICS CORPORATION. AND IS PROTECTED AS A TRADE SECRET. IT IS SUBMITTED FOR USE BY RECIPIENT ONLY FOR A BUSINESS PURPOSE AUTHORIZED BY ANIMATICS CORPORATION. ANY OTHER USE IS PROHIBITED. RECIPIENT AGREES TO KEEP SUCH INFORMATION CONFIDENTIAL.

MATERIAL <b>ALUMINUM HOUSING</b>	FINISH <b>BLACK ANODIZE HOUSING</b>	DRAWN M. TRAN	DATE 12/10/2009
THIRD ANGLE PROJECTION		ENGR	DATE

**INCH** UNLESS OTHERWISE SPECIFIED: DIMENSIONS ARE INCHES AND TOLERANCES ARE:  
 DECIMALS: .XXX ± .020 .XX ± 0.25°  
 ANGLES: .XX ± 0.5°  
 .XX ± .04 .X ± 0.5°

INTERPRET DIMENSIONS AND TOLERANCES PER ASME Y14.5M - 1994.  
 ALL DIMENSIONS, TOLERANCES AND ROUGHNESS APPLY AFTER FINISHING, WHEN APPLICABLE.  
 NO BURRS ALLOWED, BREAK SHARP EDGES .01 MAX.

**Animatics Corporation**

TITLE  
**SM3416DT-PLS2 AND SM34165DT SERIES**

SIZE **C** DWG NO **SM 3416DT 34165DT**

DO NOT SCALE DRAWING SCALE 2:3 SHEET 1 OF 1