

L70 Product Specifications

Parameter	Value	Units
Configuration & Physical Parameters		
Motor	23 Frame SmartMotors, D and M series	-
Coupling	Beam	-
Displacement/rev	5, 10	mm/rev
Position Sensors	Adjustable (3 max) NPN N/O or N/C	-
Stroke Lengths	Standard in 50mm increments to 600 Custom in 1mm increments to 600	mm
Overall Length	Stroke + 182.5 + Motor	mm
Overtravel	24.5	mm
Unit Mass	1.29 + 0.00414 x (stroke, mm) + (motor mass, kg)	kg
Performance		
Unidirectional Repeatability	3	µm
Bidirectional Repeatability	16	µm
Linear Accuracy	0.21/300	mm/mm
Continuous Thrust*	587 or 294 (5 or 10 mm/rev lead)	N
Load Rating, Dynamic** (Static)		
Payload Mass	25 or 20 (5 or 10 mm/rev lead)	kg
F. t, Thrust	200 (1140)	N
F.n, Carriage Normal	200 (400)	N
F.st, Carriage Side	200 (400)	N
F.ss, Carriage Side	100 (400)	N
Carriage moments, Dynamic** (Static)		
M.a, Carriage Moment***	5 (20)	Nm
M.b, Carriage Moment***	5 (20)	Nm
M.c, Carriage Moment***	5 (20)	Nm

*Based on using SM23165DT @ 48V @ 2000 RPM. Refer to corresponding thrust curves for details.

**Based on a basic desired service life of 15,000hr (7.5yrs single shift) @ 167 mm/s and 333mm/s (2000 RPM) average speed at given payload, subject to routine lubrication.

Consult the factory if your application exceeds these values.

***Moment capacities given about center of carriage mounting surface.

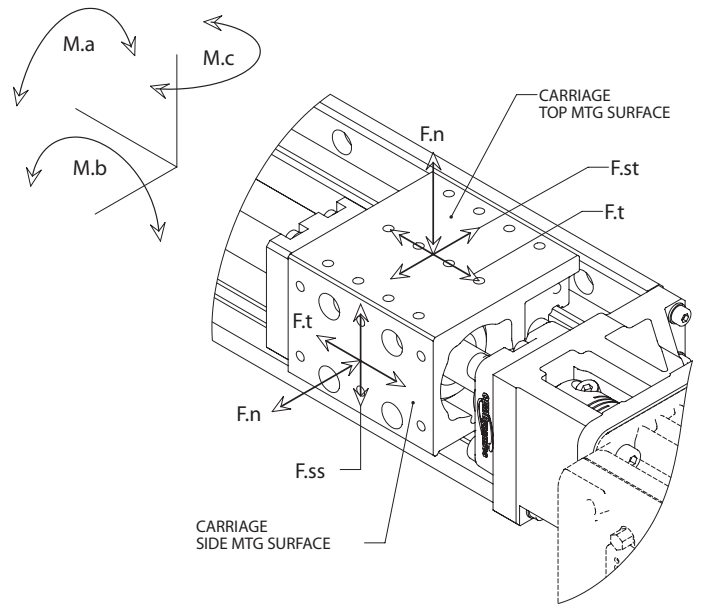
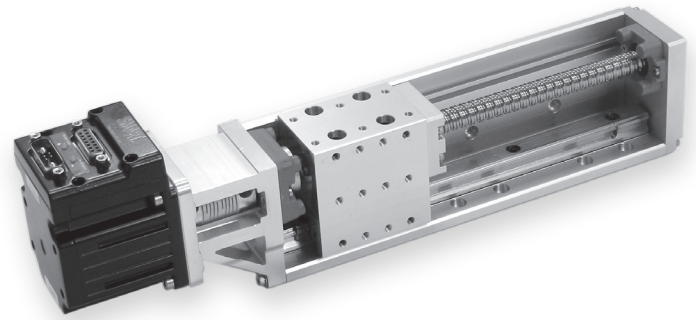

WARNING: Do not exceed these limits

L70 - Maximum Permissible Carriage Velocity

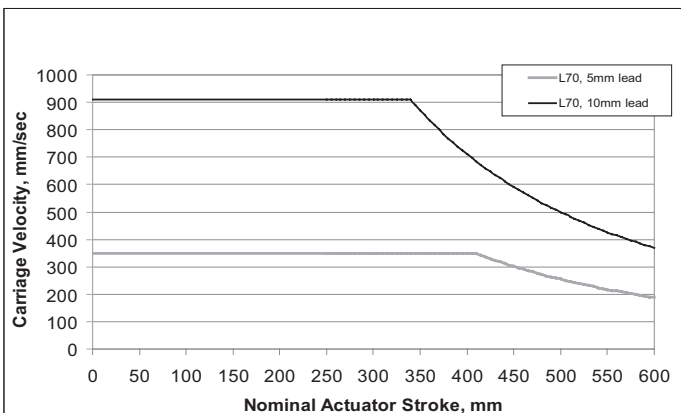

L70 - Maximum Permissible Screw Speed

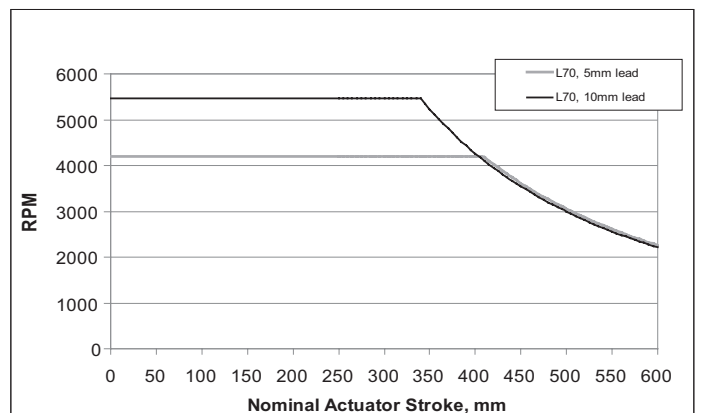

WARNING: Exceeding thrust, speed, or moment loading specifications could result in immediate damage to the actuators. Doing so will void the warranty.

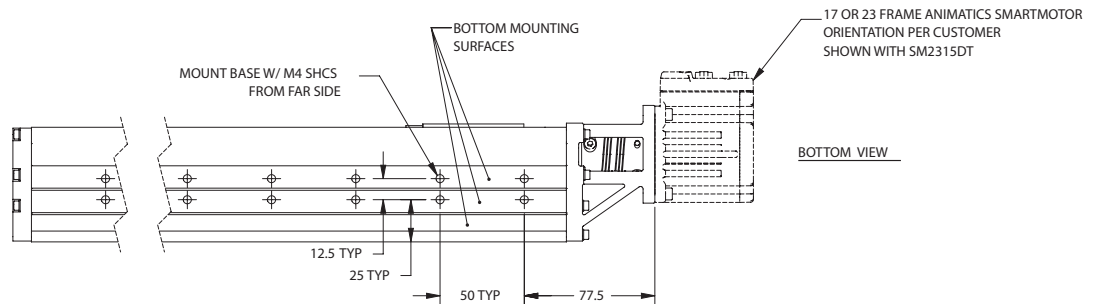
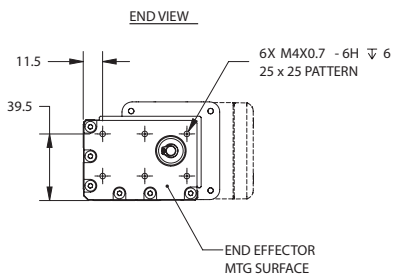
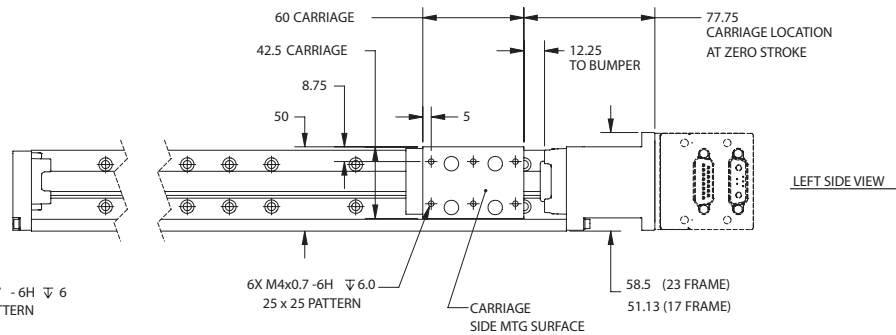
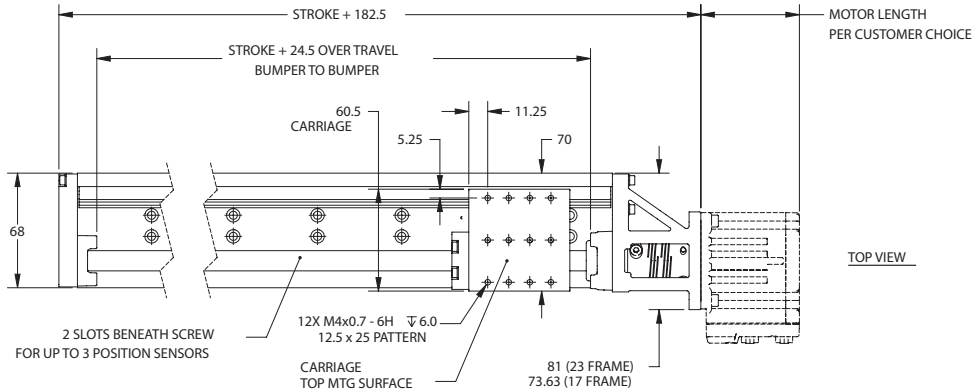
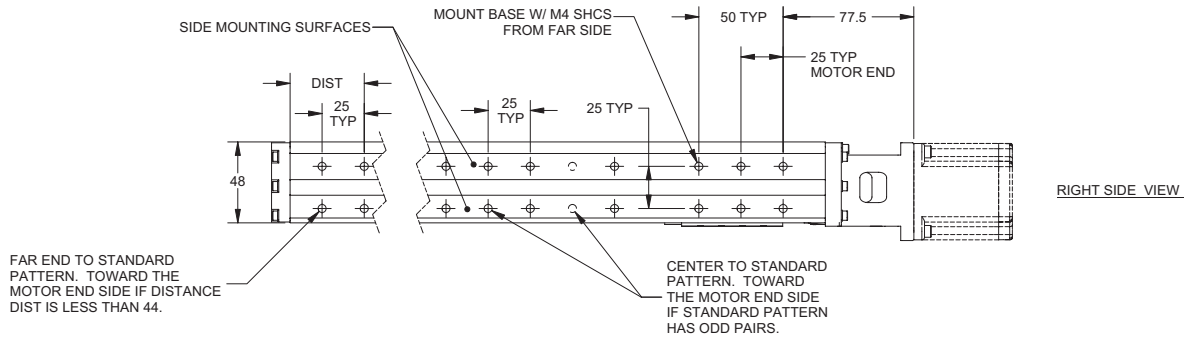

Dimensions in millimeters

NOTE: For part numbers please refer to our website at www.animatics.com

For Thrust Curve performance data, see pages 158–173.