

Which is Better, Linear or Switcher Supplies?

Because servo motors are inductive, they may run highly dynamic motion profiles. As a result, their current demand can vary widely. Surge currents from stand still to maximum load may be extremely high, yet steady state current demand over time may be relatively mild. As a result, proper care should be taken when selecting power supplies.

Moog Animatics offers two basic types of power supplies. The chart to the right gives a brief comparison of the two types of supplies.

	Linear	Switcher
AC Input	Field Selectable (120 / 240 VAC)	Universal 90-240 VAC
Power Factor Corrected	No	Yes
Relative Size	Big and Bulky	Lightweight
Cooling	Ambient Convection	Fan Cooled
Surge Capacity	400%	5%
Voltage Regulation	15% Drop Over Range	0%, Fixed
Shunt Required? ¹	Occasionally, But Not Typically	In Most Cases, Highly Recommended

¹See shunt section for more information

As seen in the graph to the right, linear (unregulated) supplies can handle large surge current loads. This is because linear supplies typically contain large output capacitors to handle those surges well.

Switch mode supplies (switchers) are highly regulated. They will maintain fixed voltage until they reach maximum load and then will “crowbar” to zero volts to protect the output stages. Linear supplies will slowly drop the output voltage while supplying more and more current.

This is the most fundamental difference between switchers and unregulated supplies.

Even though a switcher cannot handle the higher current surges, if it can output as much current as you would expect for a given servo application, then it will actually help the servo accelerate much faster. That is because the system voltage will be maintained at maximum level.

However, if your servo application requires surge currents in excess of 50 amps or more, the switchers may not be cost effective. For example, getting 50 amps from a Moog Animatics 20 amp supply is easy; getting 50 amps from Moog Animatics switchers would require placing multiple units in parallel. Therefore, it may not be cost effective to do so.

Voltage Drop Comparison

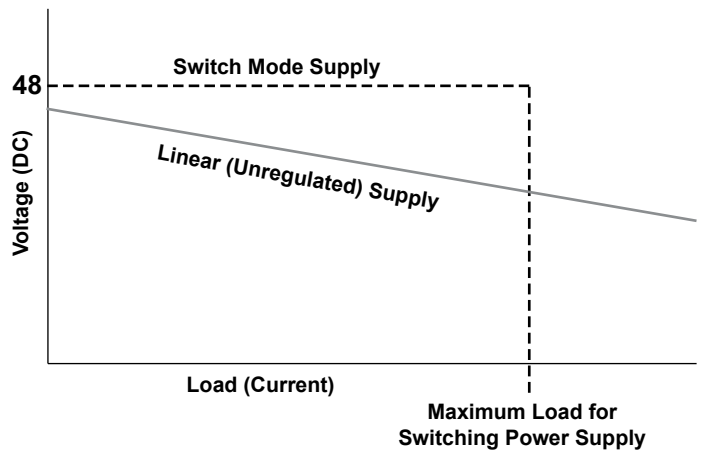

⚠ WARNING: Improper power supply sizing may result in motor position error faults, motor resets, and machine faults.

Overview

Software

C5 D-Style

C5 M-Style

C6 M-Style

C6 Low-Cost

Cables, Etc.

Actuators

Gearheads

Power Supplies

Power Supplies

- Linear unregulated
- AC input, DC output
- Screw terminal access
- Toroid transformer for lower EMI

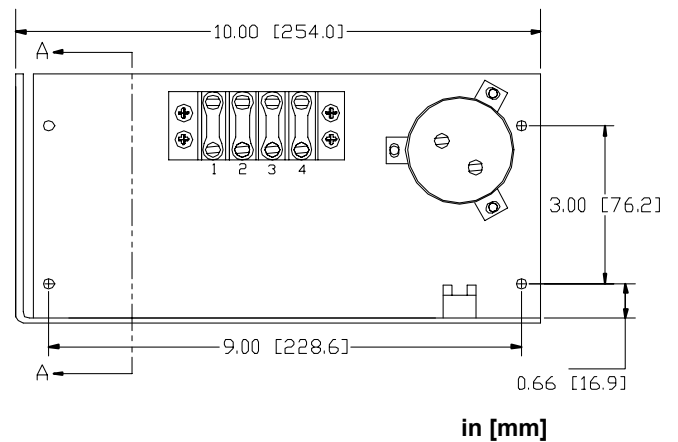
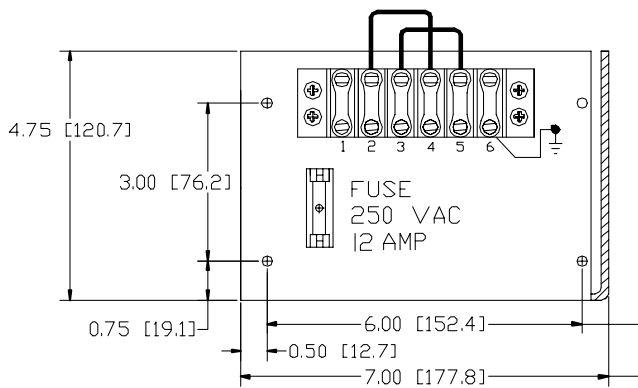
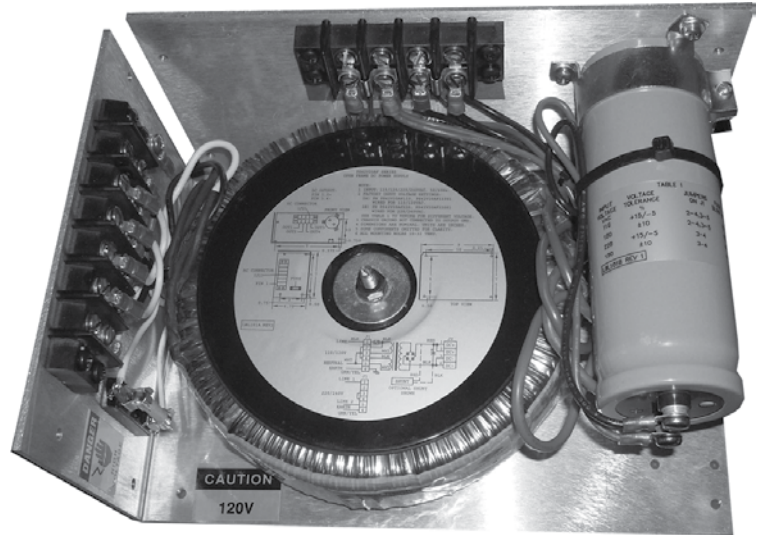

in [mm]

Part Number	Input Voltage and Frequency	No Load Output Voltage	Full Load Output		Nominal Wattage	Shunt	Weight (Nom.)
			Voltage	Current			
PS42V20AF110	120 VAC 50 / 60 Hz	44 VDC	35 VDC	20 Amps	680 W		16.5 lbs (7.5 kg)
PS42V20AF220	240 VAC 50 / 60 Hz	44 VDC	35 VDC	20 Amps	680 W		16.5 lbs (7.5 kg)
PS42V20AF110-S1	120 VAC 50 / 60 Hz	44 VDC	35 VDC	20 Amps	680 W	100 W	17 lbs (7.7 kg)
PS42V20AF220-S1	240 VAC 50 / 60 Hz	44 VDC	35 VDC	20 Amps	680 W	100 W	17 lbs (7.7 kg)
PS42V20AF110-S2	120 VAC 50 / 60 Hz	44 VDC	35 VDC	20 Amps	680 W	200 W	17 lbs (7.7 kg)
PS42V20AF220-S2	240 VAC 50 / 60 Hz	44 VDC	35 VDC	20 Amps	680 W	200 W	17 lbs (7.7 kg)

⚠ WARNING: Improper power supply sizing may result in motor position error faults, motor resets, and machine faults.

Part Number		PFC500W-48R2	PFC1500W-48
		<ul style="list-style-type: none"> • Universal AC input/full range • Built-in active PFC function, PF>0.95 • Protections: short circuit/overload/overvoltage/overtemperature • Forced-air cooling by built-in DC fan with ON/OFF control • Built-in remote ON/OFF control • Built-in remote sense function 	
Output	DC Voltage	48 V	48 V
	Rated Current	10.5 A	32 A
	Rated Power	504 W	1536 W
	Setup, Rise Time	1500 ms, 80 ms at full load	1500 ms, 100 ms at full load
Input	Voltage Range	88 – 264 VAC; 124 – 370 VDC	
	Frequency Range	47 – 63 Hz	
	Power Factor	PF>0.95 / 230 VAC PF>0.98 / 115 VAC at full load	
	Efficiency	90.5%	91%
	AC Current	5.3 A / 115 VAC 2.65 A / 230 VAC	17 A / 115 VAC 8 A / 230 VAC
Protection	Overload	105 – 130% rated power output	105 – 135% rated power output
	Overvoltage	58.4 – 68 V	57.6 – 67.2 V
	Overtemperature	Shut down o/p voltage, recovers automatically after temperature goes down	
Function	Working Temperature	-30 – +70°C	-10 – +50°C
	Working Humidity	20 – 90% RH non-condensing	
Environment	Storage Temperature	-40 – +85°C	
	Storage Humidity	10 – 95% RH	
	Vibration	10 – 500 Hz, 2G 10 min. / cycle, 60 min. each along X,Y,Z axes	
Safety and EMC	Safety Standards	UL60950-1, TUV EN60950-1 approved	
	EMI Conduction and Radiation	Compliance to EN55032 (CISPR32) Class B, EN61000-3-2,-3	Compliance to EN55022 (CISPR22) Class B, EN61000-3-2,-3
	EMS Immunity	Compliance to EN61000-4-2,3,4,5,6,8,11; EN55024, EN61000-6-2, EN61204-3 heavy industry level, criteria A	Compliance to EN61000-4-2,3,4,5,6,8,11; EN55024, EN61204-3, EN61000-6-2
Others	MTBF	187.7K hrs min. MIL-HDBK-217F (25°C)	90.3K hrs min. MIL-HDBK-217F (25°C)
	Dimensions	230 x 127 x 40.5 mm (L x W x H)	278 x 127 x 83.5 mm (L x W x H)
Notes	<ol style="list-style-type: none"> 1. All parameters NOT specially mentioned are measured at 230 VAC input, rated load and 25°C of ambient temperature. 2. Ripple and noise are measured at 20 MHz of bandwidth by using a 12 inch twisted-pair wire terminated with a 0.1 µf and 47 µf parallel capacitor. 3. Tolerance: includes setup tolerance, line regulation, and load regulation. 4. The power supply is considered a component that will be installed into the final equipment. The final equipment must be reconfirmed that it still meets EMC directives. 5. Derating may be needed under low input voltages. Please check the derating curve for more details. 6. Multiple units may be paralleled for additional power. 		

Please refer to the website for detailed diagrams and for more information.

⚠ WARNING: Improper power supply sizing may result in motor position error faults, motor resets, and machine faults.

- Enclosed linear unregulated power supplies
- PC-type with AC power cord
- 4-pin AMP connector on output
- Internally fused on both primary and secondary side
- Toroid transformer for minimal voltage drop and minimal EMI



Includes AC power cord and KITDC1 connector kit.

Part Number	Input Voltage	Hz AC	No Load Voltage	Full Load		Nominal Wattage	Weight (Nom.)
				Voltage	Current		
PS24V8AG-110	110 VAC	60	25 VDC	19 VDC	8 Amps	152 W	6.5 lbs (3 kg)
PS42V6AG-110	110 VAC	60	46 VDC	38.7 VDC	6.5 Amps	251 W	7 lbs (3.2 kg)
PS42V6A-220CE	220 VAC	50-60	46 VDC	38.7 VDC	6.5 Amps	251 W	7 lbs (3.2 kg)

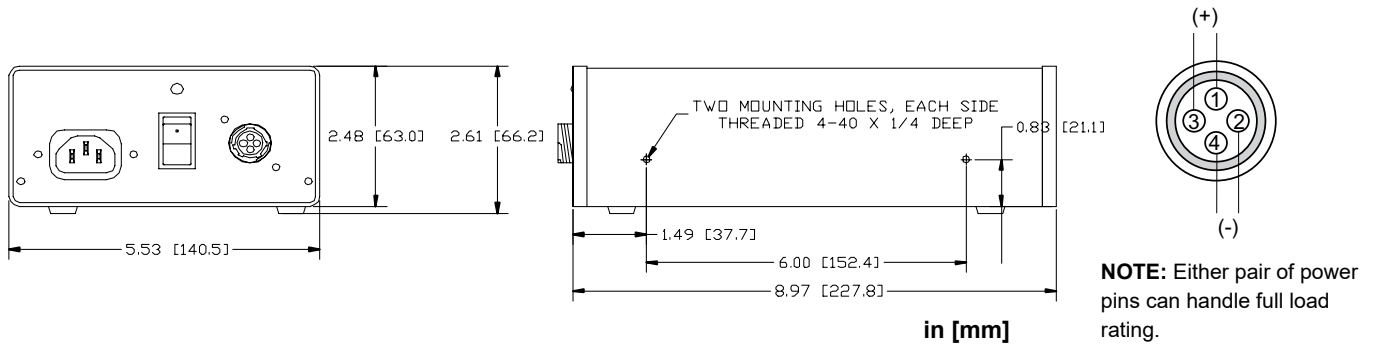

PWR116V

Enclosed laptop type power supply. This power supply connects directly to:

- CBLSM1-DEMO
- SmartBox™
- SmartBox BCD™

It is ideal for desktop testing of the SmartMotor™ and will easily run an unloaded SmartMotor for programming and evaluation testing.

Input: 100-240 VAC 50 / 60 Hz
 Output: 24 VDC, 2.5 Amps, 60 Watts
 Connector Type: 2.1 x 5 mm coax DC power connector
 Cable Length: ~1 meter

RoHS/CE Certified



CBLAC1

AC power cable for PWR116V power supply above.
 Standard 3 prong US AC plug
 ~1 meter length



⚠ WARNING: Improper power supply sizing may result in motor position error faults, motor resets, and machine faults.