

REV.	DESCRIPTION	ZONE	ECO	DATE	APPROVED
A	PRELIMINARY RELEASE			01/20/2011	M. TRAN

- NOTES:
- DRAWING APPLIES TO THE FOLLOWING SMARTMOTOR WITH PART NUMBERS:  
SM23105D-BRK SM23205D-BRK SM23305D-BRK SM23405D-BRK  
SM23105D-DEBRK SM23205D-DEBRK SM23305D-DEBRK SM23405D-DEBRK
  - LED, SERVO-AMPLIFIER:  
• CLEAR = CONTROLLER POWER NOT AVAILABLE  
• RED = FAULT  
• FLASH GREEN = DRIVE (AMPLIFIER) IS OFF  
• GREEN = DRIVE (AMPLIFIER) IS ON  
LED, TRAJECTORY  
• CLEAR = NOT IN CONTROLLED TRAJECTORY (DEFAULT STATE)  
• GREEN = IN CONTROLLED TRAJECTORY (CLOSE LOOP MOTION)  
FOR -DE OPTION, DRIVE POWER AND CONTROLLER POWER ARE ON SEPARATE PINS. MUST PROVIDE POWER TO CONTROLLER AND DRIVE POWER TO OPERATE. SEE TABLE CN2 BELOW FOR PIN ASSIGNMENT.  
DIMENSIONS IN [ ] ARE mm.
  - RECOMMENDED BOLTING SCREW SIZE TO BE 10-32 OR M5, SOCKET CAP.

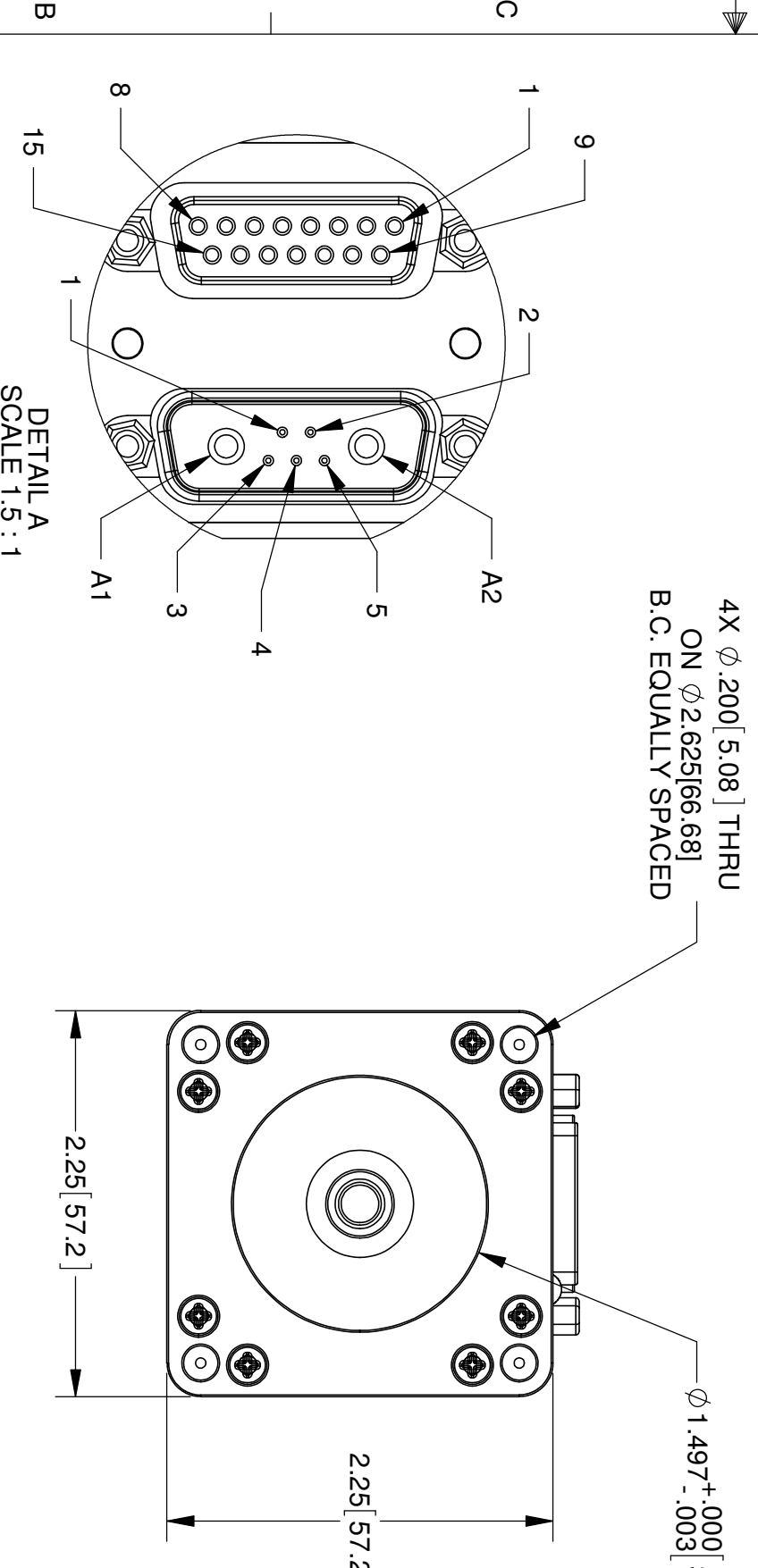
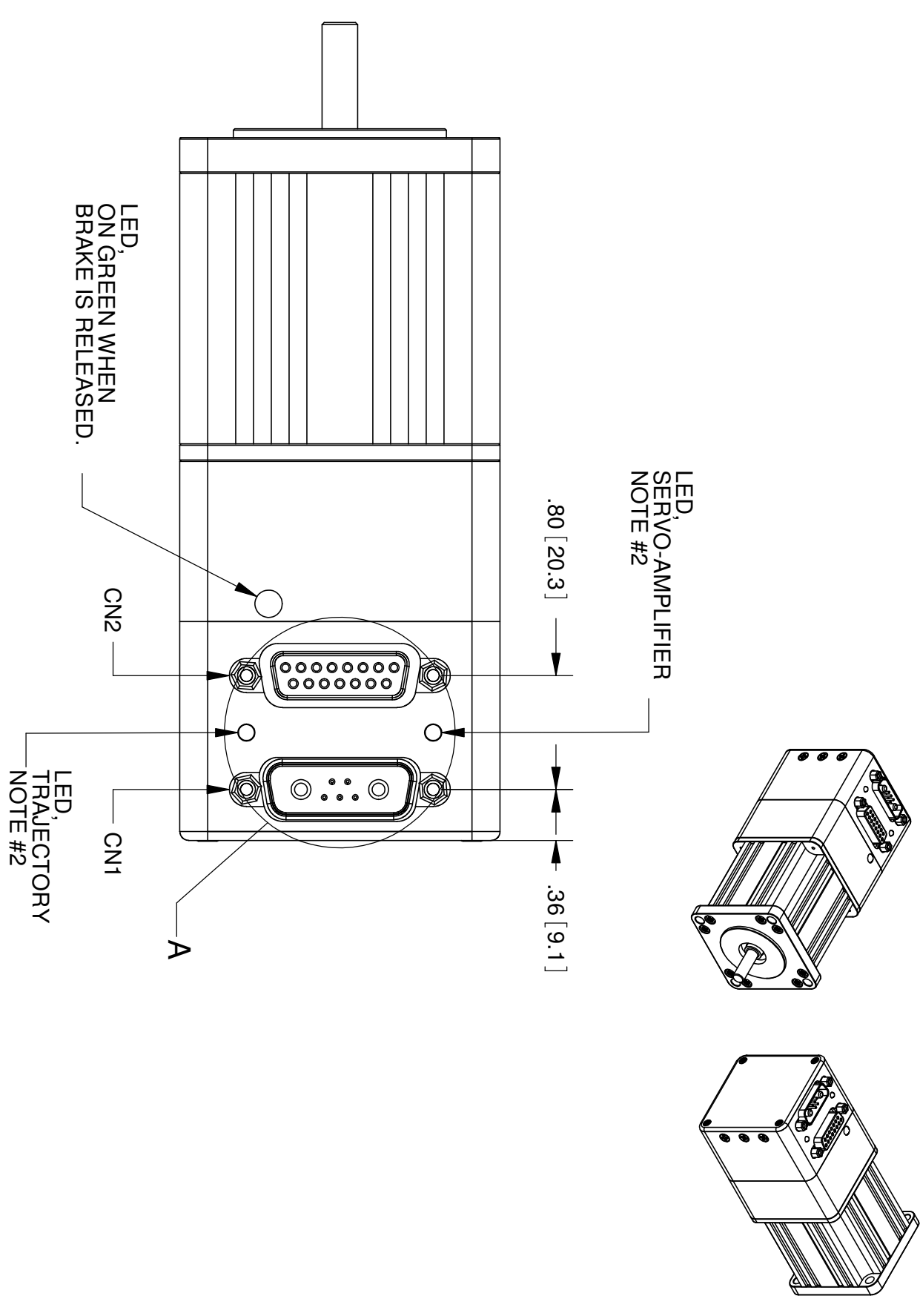

PART NUMBER	LENGTH	
	In	mm
SM23105D-BRK	4.29	109.0
SM23205D-BRK	4.88	123.8
SM23305D-BRK	5.53	140.3
SM23405D-BRK	6.18	156.8

CN2 : 15PIN D-SUB FEMALE CONNECTOR

PIN #	NAME	FUNCTIONS		
		Default Function	Secondary Function	Digital I/O Analog Input
1	I/O A	External Encoder A Input	Step Input	5V TTL 0 to 5V
2	I/O B	External Encoder B Input	Direction Input	5V TTL 0 to 5V
3	I/O C	Positive Limit Input		5V TTL 0 to 5V
4	I/O D	Negative Limit Input		5V TTL 0 to 5V
5	I/O E			5V TTL 0 to 5V
6	I/O F			5V TTL 0 to 5V
7	I/O G	G-Synchronization	RS485-ISO Adapter Data	5V TTL 0 to 5V
8	ENC A OUT	Encoder A Output		
9	ENC B OUT	Encoder B Output		
10	RS232 Tx	RS232 Transmitt		
11	RS232 Rx	RS232 Receive		
12	+5Vdc OUT	+5Vdc Supply Out		
13	GND	Signal GND		
14	POWER GND	POWER GND		
15	POWER	POWER		

For -DE Option, Pin 15 is Control power (20V to 48V) and Pin 14 is PWR GND. \*PIN 15 is not connected to A1.

CN1 : 7PIN COMBO D-Sub Male Connector

PIN #	NAME	FUNCTIONS	Ties to CN2, PIN #
1	I/O G	G-Synchronization	7
2	+5Vdc OUT	+5Vdc Output	12
3	RS232 Tx	RS232 Transmitt	10
4	RS232 Rx	RS232 Received	11
5	GND	Signal GND	13
A1	DRIVE PWR	Drive Power (20 - 48Vdc)	15
A2	POWER GND	POWER GND	14

**CONFIDENTIAL.** THE INFORMATION CONTAINED HEREIN IS THE PROPERTY OF ANIMATICS CORPORATION AND IS PROTECTED AS A TRADE SECRET. IT IS SUBMITTED FOR USE BY RECIPIENT ONLY FOR A BUSINESS PURPOSE AND IS NOT TO BE DISCLOSED OR REPRODUCED IN ANY MANNER WITHOUT THE WRITTEN PERMISSION OF ANIMATICS CORPORATION. ANY OTHER USE IS PROHIBITED. RECIPIENT AGREES TO KEEP SUCH INFORMATION CONFIDENTIAL.

**ALUMINUM HOUSING** FINISH: BLACK ANODIZED HOUSING

**INCH** UNLESS OTHERWISE SPECIFIED: DIMENSIONS ARE IN INCHES AND TOLERANCES ARE: .XXX ± .005 ANGLES: .XX ± 0.25° .XX ± .03 X ± 0.5°

INTERPRET DIMENSIONS AND TOLERANCES PER ASME Y14.5M - 1994.

ALL DIMENSIONS, TOLERANCES AND ROUGHNESS APPLY AFTER FINISHING, WHEN APPLICABLE.

NO BURRS ALLOWED. BREAK SHARP EDGES .01 MAX.

DRAWN: M. TRAN DATE: 01/20/2011

**Animatics Corporation**

**SM23X05D SERIES W/BRAKE OPTION**

SIZE: C DWG NO: SM23X05D-BRK

DO NOT SCALE DRAWING SCALE: 1:1 SHEET: 1 OF 1