

## XL100 Product Specifications

Parameter	Value	Units
<b>Configuration &amp; Physical Parameters</b>		
Motor	23 Frame SmartMotors, D and M series	-
Coupling	Beam	-
Displacement/rev	5, 10	mm/rev
Position Sensors	Adjustable (3 per side - 6 max) NPN N/O or N/C	-
Stroke Lengths	Standard in 50mm increments to 600 Custom in 1mm increments to 600	mm
Overall Length	Stroke + 223.50 + motor	mm
Overtravel	24.5	mm
Unit Mass	2.657 + 0.0049 x (stroke, mm) + (motor mass, kg)	kg
<b>Performance</b>		
Unidirectional Repeatability	3	μm
Bidirectional Repeatability	16	μm
Linear Accuracy	0.21/300	mm/mm
Continuous Thrust*	587 or 294 (5 or 10mm/rev lead)	N
<b>Load Rating, Dynamic** (Static)</b>		
Payload Mass	25 or 20 (5 or 10mm/rev lead)	kg
F. t, Thrust	200 (1140)	N
F.n, Carriage Normal	860 (15000)	N
F.st, Carriage Side	580 (1000)	N
<b>Carriage moments, Dynamic** (Static)</b>		
M.a, Carriage Moment***	25 (500)	Nm
M.b, Carriage Moment***	25 (500)	Nm
M.c, Carriage Moment***	25 (500)	Nm

\*Based on using SM23165DT @ 48V @ 2000 RPM. Refer to corresponding thrust curves for details.

\*\*Based on a basic desired service life of 15,000hr (7.5yrs single shift) @ 167 mm/s and 333mm/s (2000 RPM) average speed at given payload, subject to routine lubrication.

Consult the factory if your application exceeds these values.

\*\*\*Moment capacities given about center of carriage mounting surface.

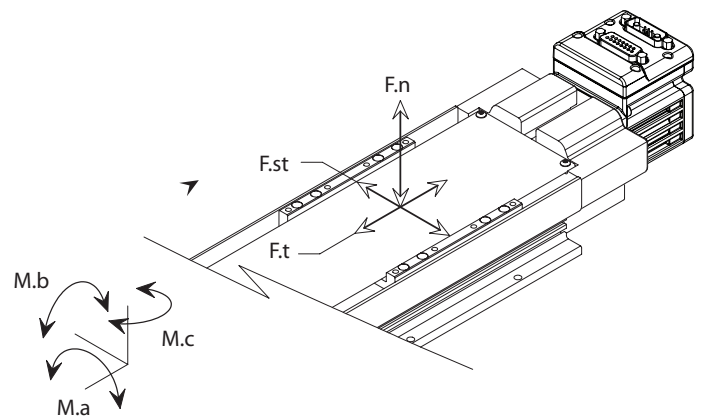

### WARNING: Do not exceed these limits

#### XL100 - Maximum Permissible Carriage Velocity

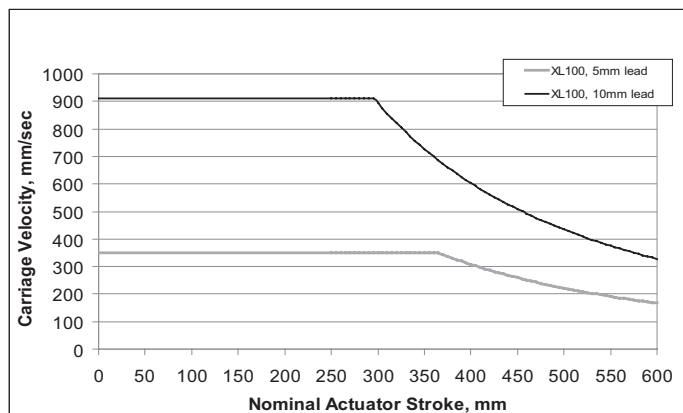

#### XL100 - Maximum Permissible Screw Speed

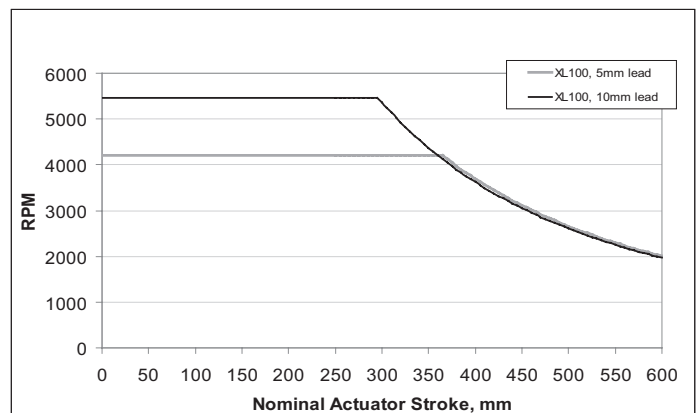

**WARNING: Exceeding thrust, speed, or moment loading specifications could result in immediate damage to the actuators. Doing so will void the warranty.**

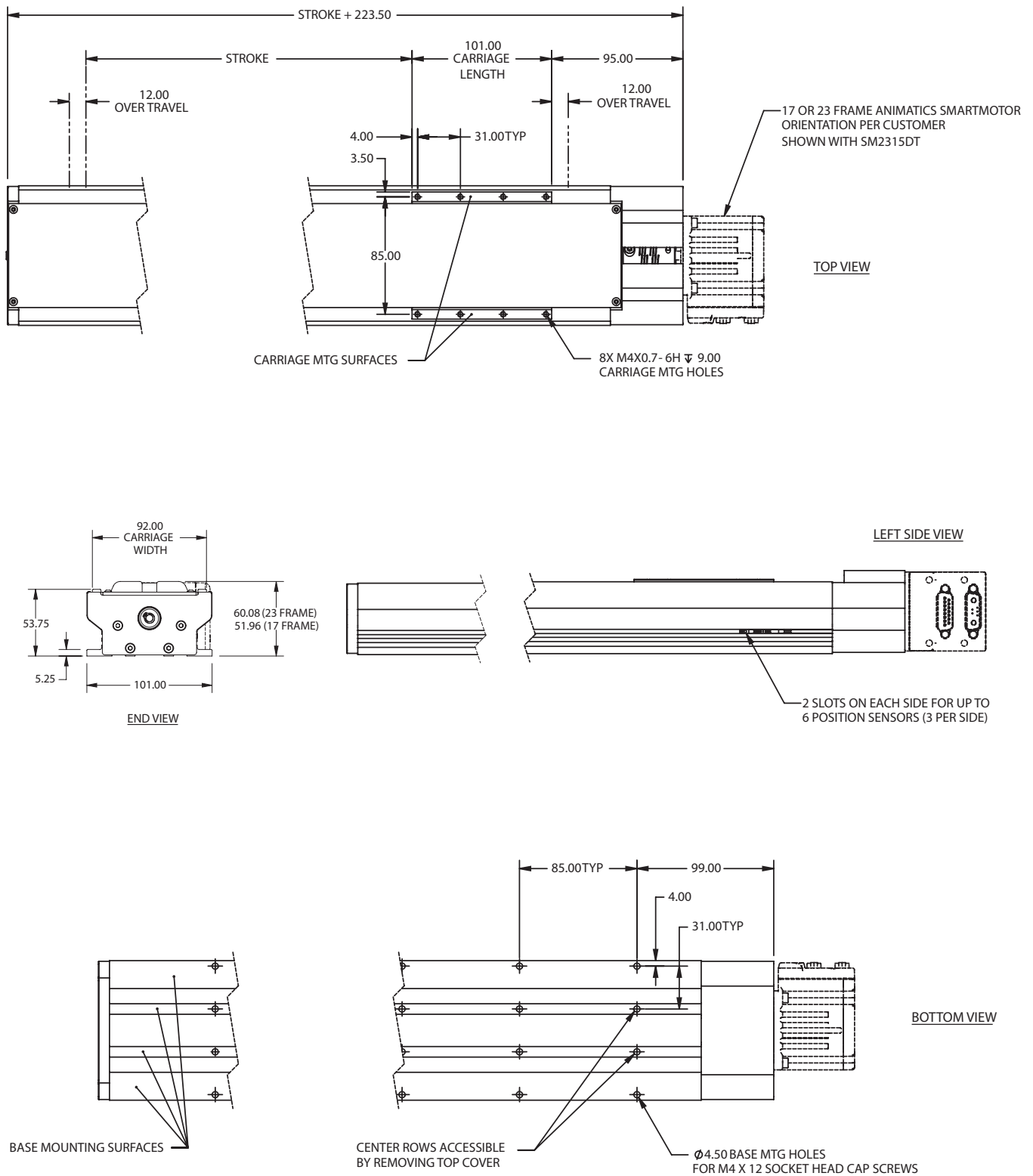

Dimensions in millimeters

**NOTE:** For part numbers please refer to our website at [www.animatics.com](http://www.animatics.com)

**For Thrust Curve performance data, see pages 158–173.**