

- NOTES:
- DRAWING APPLIES TO THE FOLLOWING SMARTMOTOR WITH PART NUMBERS:
SM17205D-AD1 SM17205D-DE-AD1
 - LED, SERVO-AMPLIFIER:
 - CLEAR = CONTROLLER POWER NOT AVAILABLE
 - RED = FAULT
 - FLASH GREEN = DRIVE (AMPLIFIER) IS OFF
 - GREEN = DRIVE (AMPLIFIER) IS ON
 - LED, TRAJECTORY
 - CLEAR = NOT IN CONTROLLED TRAJECTORY (DEFAULT STATE)
 - GREEN = IN CONTROLLED TRAJECTORY (CLOSE LOOP MOTION)
 - FOR -DE OPTION, DRIVE POWER AND CONTROLLER POWER ARE ON SEPARATE PINS. MUST PROVIDE POWER TO CONTROLLER AND DRIVE POWER TO OPERATE. SEE TABLE CN2 BELOW FOR PIN ASSIGNMENT.
 - DIMENSIONS IN [] ARE mm.
 - RECOMMENDED BOLTING SCREW SIZE TO BE 4-40.

REV.	DESCRIPTION	ZONE	ECO	DATE	APPROVED
A	PRELIMINARY RELEASE			1/27/2011	M. TRAN

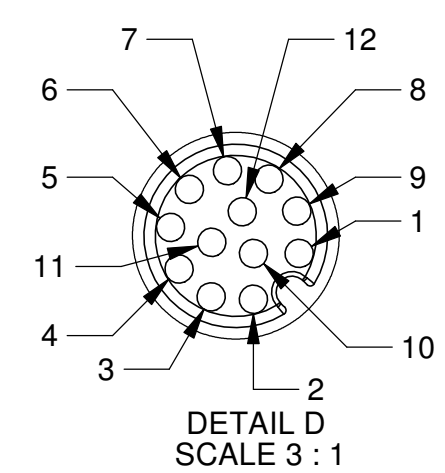
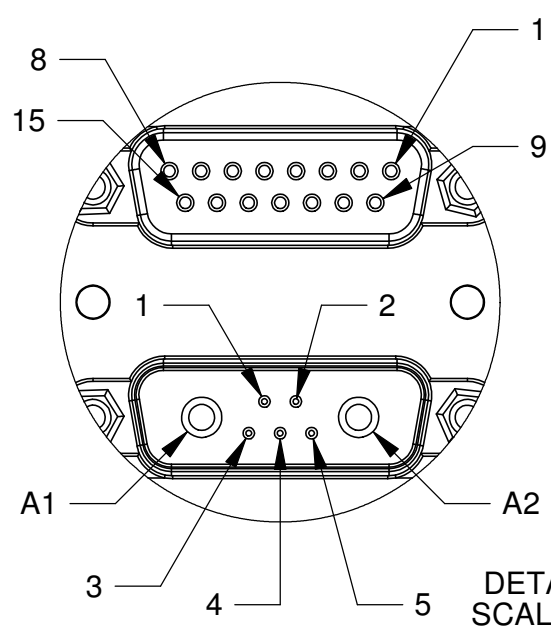
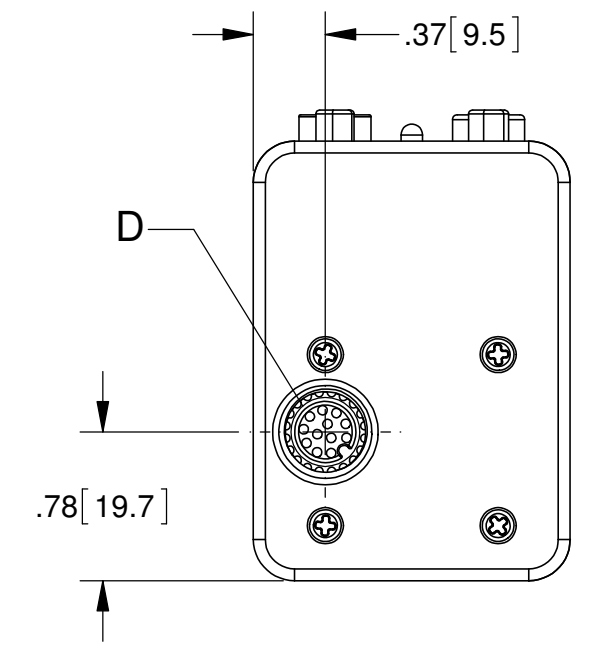
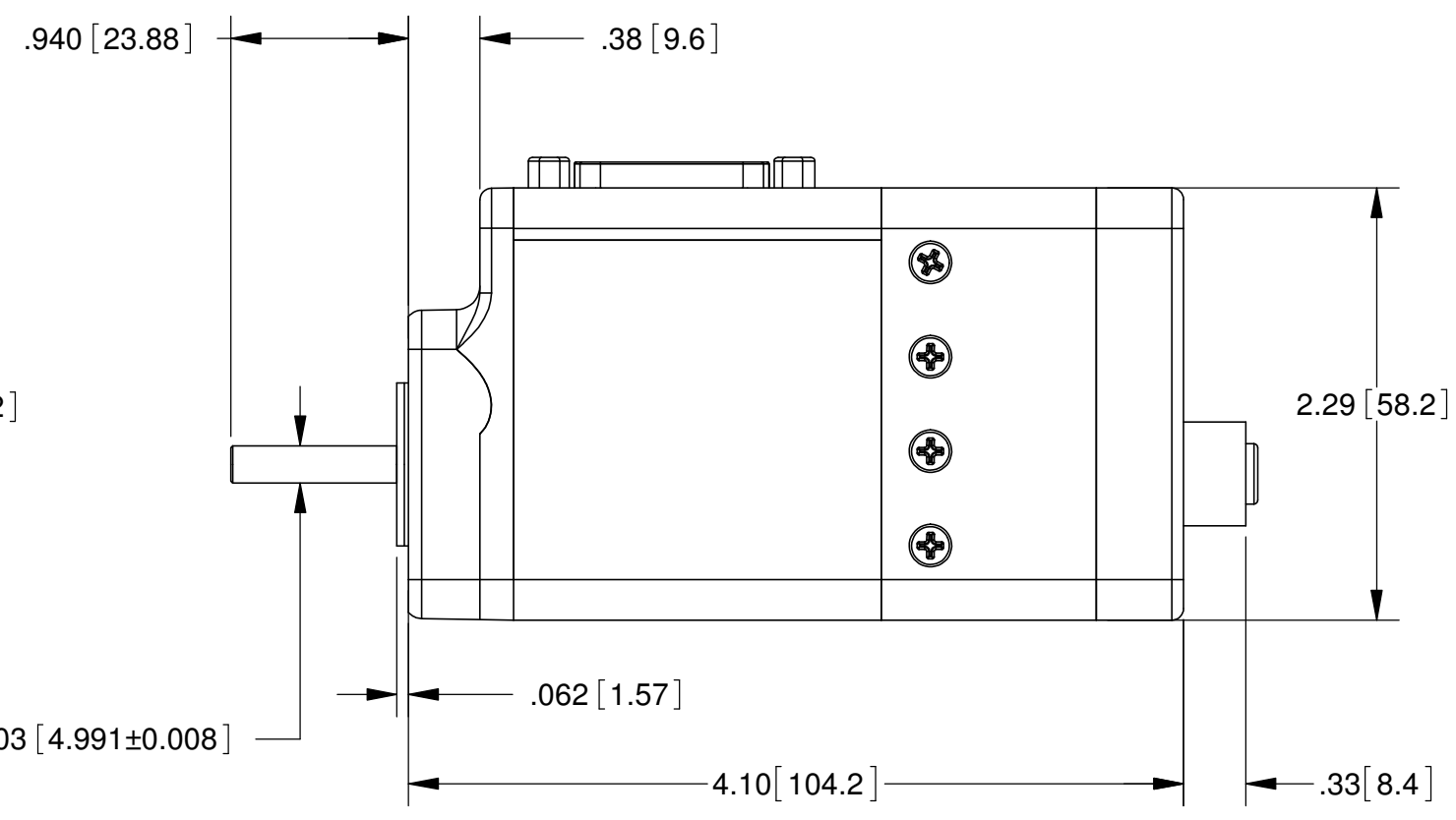
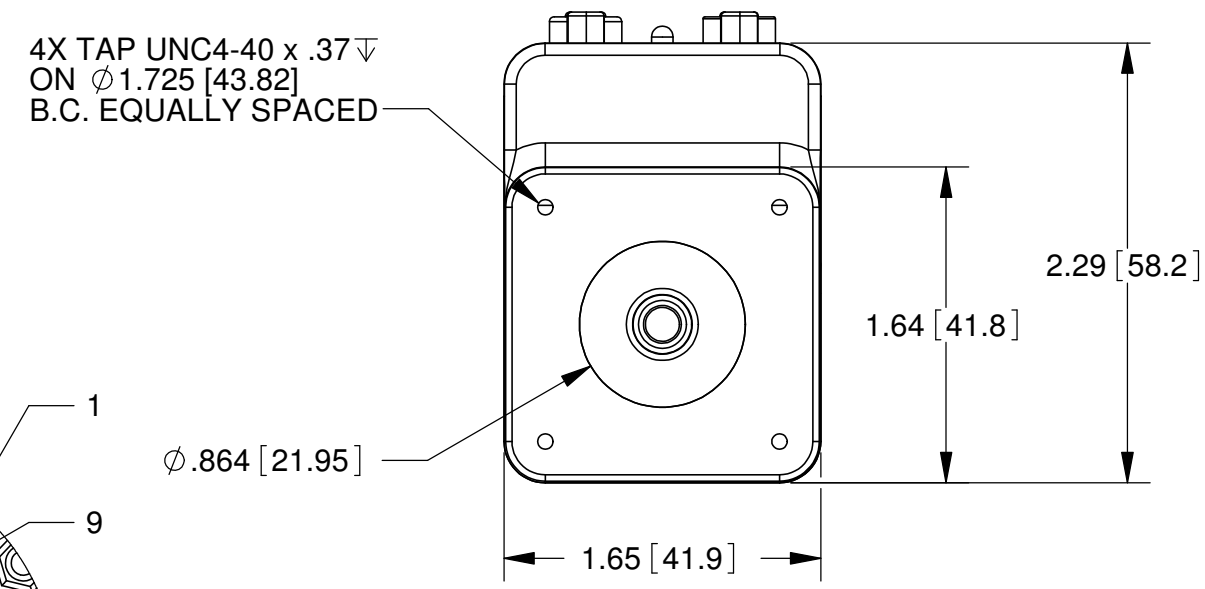
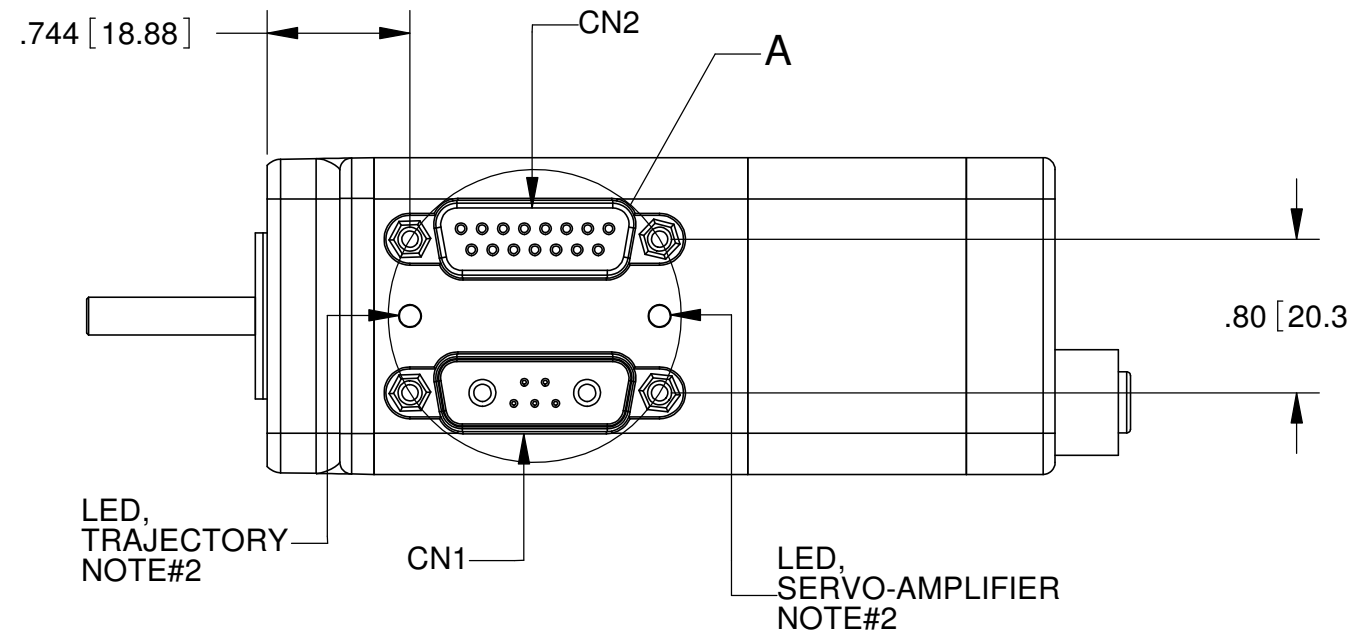
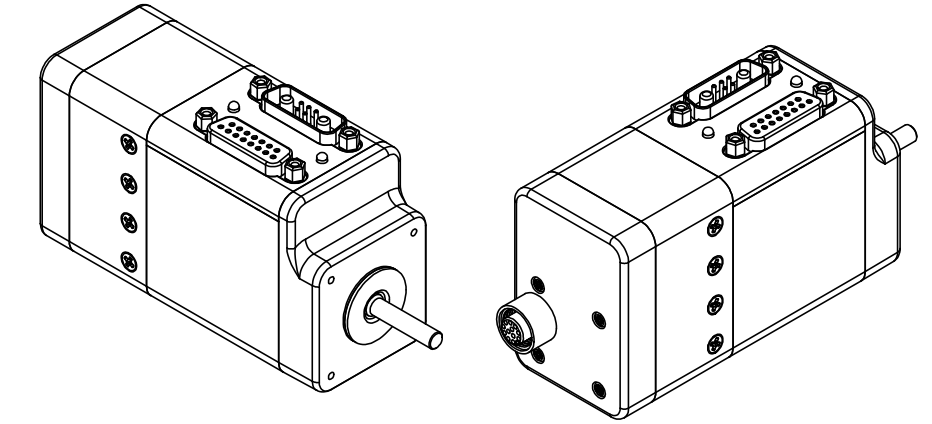

24V EXPANSION I/O	
12-Pin M12, Female connector	
PIN #	NAME
1	24V I/O #1
2	24V I/O #2
3	24V I/O #3
4	24V I/O #4
5	24V I/O #5
6	24V I/O #6
7	24V I/O #7
8	24V I/O #8
9	24V I/O #9
10	24V I/O #10
11	24V PWR IN
12	GND (I/O)

CN2 : 15PIN D-SUB FEMALE CONNECTOR					
PIN #	NAME	FUNCTIONS			
		Default Function	Secondary Function	Digital I/O	Analog Input
1	I/O A	External Encoder A Input	Step Input	5V TTL	0 to 5V
2	I/O B	External Encoder B Input	Direction Input	5V TTL	0 to 5V
3	I/O C	Positive Limit Input		5V TTL	0 to 5V
4	I/O D	Negative Limit Input		5V TTL	0 to 5V
5	I/O E		RS485 A (+)	5V TTL	0 to 5V
6	I/O F		RS485 B (-)	5V TTL	0 to 5V
7	I/O G	G-Synchronization	RS485-ISO Adaptor Data	5V TTL	0 to 5V
8	ENC A OUT	Encoder A Output			
9	ENC B OUT	Encoder B Output			
10	RS232 Tx	RS232 Transmit			
11	RS232 Rx	RS232 Receive			
12	+5Vdc OUT	+5Vdc Supply Out			
13	GND	Signal GND			
14	POWER GND	POWER GND	For -DE Option, Pin 15 is Contorl power (20V to 48V) and Pin 14 is PWR GND. ^PIN 15 is not connected to A1.		
15	POWER	POWER			

CN1 : 7PIN COMBO D-Sub Male Connector				
PIN #	NAME	FUNCTIONS	Ties to CN2, PIN #	
1	I/O G	G-Synchronization	7	
2	+5V dc OUT	+5Vdc Output	12	
3	RS232 Tx	RS232 Transmit	10	
4	RS232 Rx	RS232 Received	11	
5	GND	Signal GND	13	
A1	DRIVE PWR	Dirve Power (20 - 48Vdc)	15^	
A2	POWER GND	POWER GND	14	

CONFIDENTIAL. THE INFORMATION CONTAINED HEREIN IS THE PROPRIETY PROPERTY OF ANIMATICS CORPORATION. AND IS PROTECTED AS A TRADE SECRET. IT IS SUBMITTED FOR USE BY RECIPIENT ONLY FOR A BUSINESS PURPOSE AUTHORIZED BY ANIMATICS CORPORATION. ANY OTHER USE IS PROHIBITED. RECIPIENT AGREES TO KEEP SUCH INFORMATION CONFIDENTIAL.

MATERIAL ALUMINUM HOUSING	FINISH BLACK ANODIZED HOUSING	DRAWN M. TRAN	DATE 1/27/2011
UNLESS OTHERWISE SPECIFIED: DIMENSIONS ARE INCHES AND TOLERANCES ARE: DECIMALS: .XXX ± .005 ANGLES: .XX ± 0.25° .XX ± .03 .X ± 0.5°		ENGR	DATE

INTERPRET DIMENSIONS AND TOLERANCES PER ASME Y14.5M - 1994.
ALL DIMENSIONS, TOLERANCES AND ROUGHNESS APPLY AFTER FINISHING, WHEN APPLICABLE.
NO BURRS ALLOWED, BREAK SHARP EDGES .01 MAX.

Animatics Corporation

TITLE: **SM17205D SERIES W/EXT 24VIO OPTION**

SIZE: **C** DWG NO: **SM17205D-AD1**

DO NOT SCALE DRAWING SCALE: 1:1 SHEET: 1 OF 1