

INSTALLATION AND STARTUP FOR

# FULLY INTEGRATED SERVO MOTOR

CLASS 6 SMARTMOTOR™ WITH  
COMBITRONIC™ TECHNOLOGY

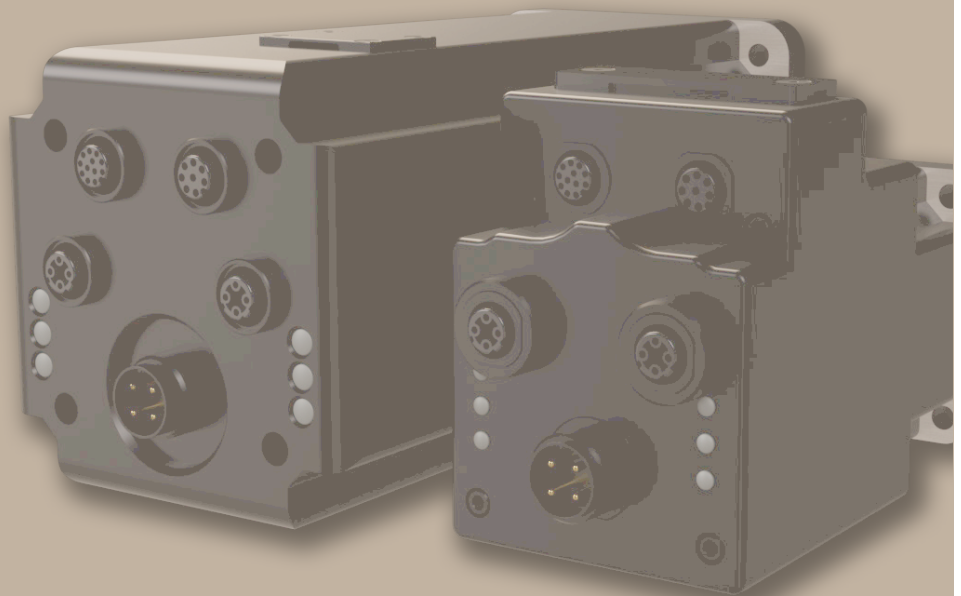

Rev. L, February 2026

DESCRIBES THE INSTALLATION AND  
STARTUP OF THE CLASS 6 M-STYLE  
SMARTMOTOR™

[www.animatics.com](http://www.animatics.com)

**MOOG**  
 **ANIMATICS**

# Copyright Notice

©2015-2026 Moog Inc.

Moog Animatics Class 6 M-Style SmartMotor™ Installation and Startup Guide, Rev. L, SC80100006-001.

This manual, as well as the software described in it, is furnished under license and may be used or copied only in accordance with the terms of such license. The content of this manual is furnished for informational use only, is subject to change without notice and should not be construed as a commitment by Moog Inc., Animatics. Moog Inc., Animatics assumes no responsibility or liability for any errors or inaccuracies that may appear herein.

Except as permitted by such license, no part of this publication may be reproduced, stored in a retrieval system or transmitted, in any form or by any means, electronic, mechanical, recording, or otherwise, without the prior written permission of Moog Inc., Animatics.

The programs and code samples in this manual are provided for example purposes only. It is the user's responsibility to decide if a particular code sample or program applies to the application being developed and to adjust the values to fit that application.

Moog Animatics and the Moog Animatics logo, SmartMotor and the SmartMotor logo, Combitronic and the Combitronic logo are all trademarks of Moog Inc., Animatics. Other trademarks are the property of their respective owners.

Please let us know if you find any errors or omissions in this manual so that we can improve it for future readers. Such notifications should contain the words " Class 6 M-Style SmartMotor Installation and Startup Guide" in the subject line and be sent by e-mail to: [animatics\\_sales@moog.com](mailto:animatics_sales@moog.com). Thank you in advance for your contribution.

Contact Us:

Moog Animatics  
1995 NC Hwy 141  
Murphy, NC 28906  
USA

Website: [www.animatics.com](http://www.animatics.com)

Email: [animatics\\_sales@moog.com](mailto:animatics_sales@moog.com)

---

# Table Of Contents

<b>Introduction</b> .....	<b>6</b>
Purpose .....	7
Combitronic Technology .....	7
Safety Information .....	8
Safety Symbols .....	8
Other Safety Considerations .....	8
Motor Sizing .....	8
Environmental Considerations .....	8
Machine Safety .....	9
Documentation and Training .....	9
Additional Equipment and Considerations .....	10
Safety Information Resources .....	10
Additional Documents .....	11
Related Guides .....	11
Other Documents .....	11
Additional Resources .....	12
<b>SmartMotor Overview</b> .....	<b>13</b>
SmartMotor Introduction .....	14
SmartMotor Features and Options .....	15
Class 6 M-Style Motors .....	15
Standard Features .....	15
Optional Features .....	16
Connectors and LED Locations .....	16
Fieldbus Options .....	18
EtherCAT Fieldbus Protocol .....	18
PROFINET Fieldbus Protocol .....	18
EtherNet/IP Fieldbus Protocol .....	18
SmartMotor Theory of Operation .....	19
<b>Getting Started</b> .....	<b>21</b>
Unpacking and Verifying Your Shipment .....	23
Installing the SMI Software .....	23
Installation Procedure .....	23
Installation Verification .....	26
Accessing the SMI Software Interface .....	26
Understanding the Power Requirements .....	28

---

SmartMotor Power Requirements .....	28
CPU, I/O and Communications Power .....	28
CPU Power Requirements .....	28
I/O Power Requirements .....	29
Communications Power Requirements .....	29
Drive Enable Input .....	29
Connecting the System .....	30
Minimum Requirements .....	30
Motor Connectors and Pinouts .....	31
Power and RS-485 Com Multidrop .....	32
USB Connector and Cable .....	32
Industrial Ethernet Network .....	34
Min and Max Cable Length .....	35
Moog Animatics Industrial Ethernet Cables .....	35
M-style to M-style Ethernet Cable .....	35
M-style to RJ45 Ethernet Cable .....	35
Ethernet Cable Schematic .....	36
Understanding the Status LEDs .....	37
Status LEDs .....	37
Understanding the SD Card .....	38
SD Card Location and LED Indicator .....	38
SD Card Requirements .....	38
SD Card Configuration .....	39
SD Card Operation .....	39
SD Card Status Bits .....	39
Detecting and Communicating with the SmartMotors .....	40
Understanding the Detection and Configuration Options .....	40
Using the Find Motors Button .....	40
Using the Detect Motors Feature .....	43
Checking and Clearing the Status Bits .....	45
Polling the Motor .....	46
Clearing the Overtravel Limits and Fault Bits .....	47
Moving the SmartMotor .....	48
Making the Motor Move .....	48
Setting and Reporting Torque .....	49
Checking the Motor Position .....	50
Viewing the Motor Position with a Report Command .....	50
Viewing the Motor Position with the Motor View Tool .....	50

---

<b>Connectors, Pinouts and Examples</b> .....	<b>52</b>
Class 6 M-Style Connector Pinouts .....	53
Class 6 I/O Connection Examples .....	54
<b>Other Class 6 M-Style Changes</b> .....	<b>57</b>
EOBK(IO) Command Limitations .....	58
Ethernet Error, Status Word 2 Bit 6 .....	58
I/O Control Details .....	58
I/O Control Examples .....	59
Scale Factor Calculation - Sample Rates .....	59
Commands for Class 6 .....	60
Commands That Have Changed .....	60
Commands Not Supported .....	61
Commands Supporting the DS2020 Combitronic System .....	61
Features not Available in Class 6 M-Style .....	61
<b>Troubleshooting</b> .....	<b>62</b>
<b>For Further Information...</b> .....	<b>63</b>

# Introduction

This chapter provides information on the purpose of the manual, safety information, and additional documents and resources.

<b>Purpose</b> .....	<b>7</b>
Combitronic Technology .....	7
<b>Safety Information</b> .....	<b>8</b>
Safety Symbols .....	8
Other Safety Considerations .....	8
Motor Sizing .....	8
Environmental Considerations .....	8
Machine Safety .....	9
Documentation and Training .....	9
Additional Equipment and Considerations .....	10
Safety Information Resources .....	10
<b>Additional Documents</b> .....	<b>11</b>
Related Guides .....	11
Other Documents .....	11
<b>Additional Resources</b> .....	<b>12</b>

## Purpose

The *Class 6 M-Style SmartMotor™ Installation and Startup Guide* (the document you are currently reading) provides an overview of the Class 6 M-Style SmartMotor, along with information on unpacking, installation and start up. This guide is meant to be used in conjunction with the *SmartMotor™ Developer's Guide*, which describes the SmartMotor features, SMI software, programming, commands, and other topics related to SmartMotor application development.

**NOTE:** The guide applies to all Class 6 M-style motors (see the next figure). However, some features/functions described in this guide apply only to Class 6 MT2 motors.

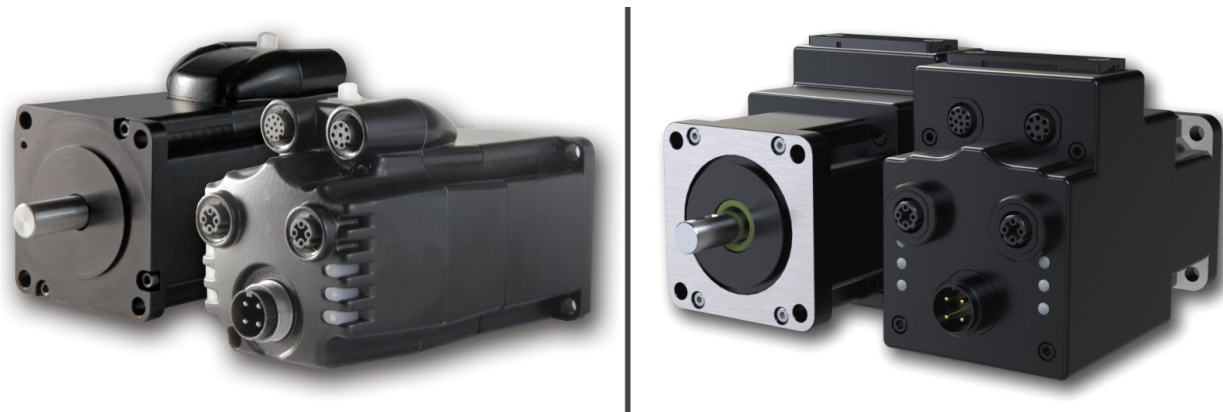

*Class 6 MT (Left) vs. MT2 (Right)*

The information in this guide is meant to be used by properly trained technical personnel only. Moog Animatics conducts classroom-style SmartMotor training several times per year, as well as product seminars and other training opportunities. For more information, please see the Moog Animatics website or contact your Moog Animatics representative.

## Combitronic Technology

**NOTE:** Combitronic over Ethernet requires the -EIP option Class 6 M-style SmartMotor with the netX 52 processor, NXF EIP version 3.4.0.5 or later, and SmartMotor firmware 6.0.2.35 or later.

The most unique feature of the SmartMotor is its ability to communicate with other Class 6 M-style SmartMotors and share resources using Moog Animatics' Combitronic™ technology. Combitronic is a protocol that typically operates over a standard CAN interface. However, in the case of the Class 6 SmartMotor, it operates over Ethernet. In other words, the user commands that are supported through Combitronic over CANopen are just shifted to Ethernet. For example, the RPA command and many others are supported, as well as the PTS family of commands. Combitronic over Ethernet requires no single dedicated controller<sup>1</sup> to operate. Each SmartMotor connected to the same network communicates on an equal footing, sharing all information, and therefore, sharing all processing resources.

For additional details, see the *SmartMotor™ Developer's Guide*.

---

<sup>1</sup>Moog Animatics has replaced the terms "master" and "slave" with "controller" and "follower", respectively.

## Safety Information

This section describes the safety symbols and other safety information.

### Safety Symbols

The manual may use one or more of these safety symbols:



**WARNING:** This symbol indicates a potentially nonlethal mechanical hazard, where failure to comply with the instructions could result in serious injury to the operator or major damage to the equipment.

---



**CAUTION:** This symbol indicates a potentially minor hazard, where failure to comply with the instructions could result in slight injury to the operator or minor damage to the equipment.

---

**NOTE:** Notes are used to emphasize non-safety concepts or related information.

### Other Safety Considerations

The Moog Animatics SmartMotors are supplied as components that are intended for use in an automated machine or system. As such, it is beyond the scope of this manual to attempt to cover all the safety standards and considerations that are part of the overall machine/system design and manufacturing safety. Therefore, this information is intended to be used only as a general guideline for the machine/system designer.

It is the responsibility of the machine/system designer to perform a thorough "Risk Assessment" and to ensure that the machine/system and its safeguards comply with the safety standards specified by the governing authority (for example, ISO, OSHA, UL, etc.) for the site where the machine is being installed and operated. For more details, see Machine Safety on page 9.

### Motor Sizing

It is the responsibility of the machine/system designer to select SmartMotors that are properly sized for the specific application. Undersized motors may: perform poorly, cause excessive downtime or cause unsafe operating conditions by not being able to handle the loads placed on them. The *System Best Practices* document, which is available on the Moog Animatics website, contains information and equations that can be used for selecting the appropriate motor for the application.

Replacement motors must have the same specifications and firmware version used in the approved and validated system. Specification changes or firmware upgrades require the approval of the system designer and may require another Risk Assessment.

### Environmental Considerations

It is the responsibility of the machine/system designer to evaluate the intended operating environment for dust, high-humidity or presence of water (for example, a food-processing environment that requires water or steam wash down of equipment), corrosives or chemicals that may come in contact with the machine, etc. Moog Animatics manufactures specialized IP-rated motors for operating in extreme conditions. For details, see the *Moog Animatics Product Catalog*.

## Machine Safety

In order to protect personnel from any safety hazards in the machine or system, the machine/system builder must perform a "Risk Assessment", which is often based on the ISO 13849 standard. The design/implementation of barriers, emergency stop (E-stop) mechanisms and other safeguards will be driven by the Risk Assessment and the safety standards specified by the governing authority (for example, ISO, OSHA, UL, etc.) for the site where the machine is being installed and operated. The methodology and details of such an assessment are beyond the scope of this manual. However, there are various sources of Risk Assessment information available in print and on the internet.

**NOTE:** The next list is an example of items that would be evaluated when performing the Risk Assessment. Additional items may be required. The safeguards must ensure the safety of all personnel who may come in contact with or be in the vicinity of the machine.

In general, the machine/system safeguards must:

- Provide a barrier to prevent unauthorized entry or access to the machine or system. The barrier must be designed so that personnel cannot reach into any identified danger zones.
- Position the control panel so that it is outside the barrier area but located for an unrestricted view of the moving mechanism. The control panel must include an E-stop mechanism. Buttons that start the machine must be protected from accidental activation.
- Provide E-stop mechanisms located at the control panel and at other points around the perimeter of the barrier that will stop all machine movement when tripped.
- Provide appropriate sensors and interlocks on gates or other points of entry into the protected zone that will stop all machine movement when tripped.
- Ensure that if a portable control/programming device is supplied (for example, a hand-held operator/programmer pendant), the device is equipped with an E-stop mechanism.

**NOTE:** A portable operation/programming device requires *many* additional system design considerations and safeguards beyond those listed in this section. For details, see the safety standards specified by the governing authority (for example, ISO, OSHA, UL, etc.) for the site where the machine is being installed and operated.

- Prevent contact with moving mechanisms (for example, arms, gears, belts, pulleys, tooling, etc.).
- Prevent contact with a part that is thrown from the machine tooling or other part-handling equipment.
- Prevent contact with any electrical, hydraulic, pneumatic, thermal, chemical or other hazards that may be present at the machine.
- Prevent unauthorized access to wiring and power-supply cabinets, electrical boxes, etc.
- Provide a proper control system, program logic and error checking to ensure the safety of all personnel and equipment (for example, to prevent a run-away condition). The control system must be designed so that it does not automatically restart the machine/system after a power failure.
- Prevent unauthorized access or changes to the control system or software.

## Documentation and Training

It is the responsibility of the machine/system designer to provide documentation on safety, operation, maintenance and programming, along with training for all machine operators, maintenance technicians, programmers, and other personnel who may have access to the machine. This documentation must include proper lockout/tagout procedures for maintenance and programming operations.

It is the responsibility of the operating company to ensure that:

- All operators, maintenance technicians, programmers and other personnel are tested and qualified before acquiring access to the machine or system.
- The above personnel perform their assigned functions in a responsible and safe manner to comply with the procedures in the supplied documentation and the company safety practices.
- The equipment is maintained as described in the documentation and training supplied by the machine/system designer.

### Additional Equipment and Considerations

The Risk Assessment and the operating company's standard safety policies will dictate the need for additional equipment. In general, it is the responsibility of the operating company to ensure that:

- Unauthorized access to the machine is prevented at all times.
- The personnel are supplied with the proper equipment for the environment and their job functions, which may include: safety glasses, hearing protection, safety footwear, smocks or aprons, gloves, hard hats and other protective gear.
- The work area is equipped with proper safety equipment such as first aid equipment, fire suppression equipment, emergency eye wash and full-body wash stations, etc.
- There are no modifications made to the machine or system without proper engineering evaluation for design, safety, reliability, etc., and a Risk Assessment.

### Safety Information Resources

Additional SmartMotor safety information can be found on the Moog Animatics website; open the topic "Controls - Notes and Cautions" located at:

<https://www.animatics.com/support/downloads/knowledgebase/controls---notes-and-cautions.html>

OSHA standards information can be found at:

<https://www.osha.gov/law-regs.html>

ANSI-RIA robotic safety information can be found at:

<http://www.robotics.org/robotic-content.cfm/Robotics/Safety-Compliance/id/23>

UL standards information can be found at:

<http://ulstandards.ul.com/standards-catalog/>

ISO standards information can be found at:

<http://www.iso.org/iso/home/standards.htm>

EU standards information can be found at:

[http://ec.europa.eu/growth/single-market/european-standards/harmonised-standards/index\\_en.htm](http://ec.europa.eu/growth/single-market/european-standards/harmonised-standards/index_en.htm)

## Additional Documents

The Moog Animatics website contains additional documents that are related to the information in this manual. Please refer to these lists.

### Related Guides

- *SmartMotor™ Developer's Guide*  
<http://www.animatics.com/smartmotor-developers-guide>
- *SmartMotor™ Homing Procedures and Methods Application Note*  
<http://www.animatics.com/homing-application-note>
- *SmartMotor™ System Best Practices Application Note*  
<http://www.animatics.com/system-best-practices-application-note>

In addition to the documents listed above, guides for fieldbus protocols and more can be found on the website: <https://www.animatics.com/support/downloads.manuals.html>

### Other Documents

- SmartMotor™ Certifications  
<https://www.animatics.com/certifications.html>
- *SmartMotor Developer's Worksheet*  
(interactive tools to assist developer: Scale Factor Calculator, Status Words, CAN Port Status, Serial Port Status, RMODE Decoder and Syntax Error Codes)  
<https://www.animatics.com/support/downloads.knowledgebase.html>
- *Moog Animatics Product Catalog*  
<http://www.animatics.com/support/moog-animatics-catalog.html>

## Additional Resources

The Moog Animatics website contains useful resources such as product information, documentation, product support and more. Please refer to these addresses:

- General company information:  
<http://www.animatics.com>
- Product information:  
<http://www.animatics.com/products.html>
- Product support (Downloads, How-to Videos, Forums and more):  
<http://www.animatics.com/support.html>
- Contact information, distributor locator tool, inquiries:  
<https://www.animatics.com/contact-us.html>
- Applications (Application Notes and Case Studies):  
<http://www.animatics.com/applications.html>

## SmartMotor Overview

This chapter provides an overview of the design philosophy and functionality of the Moog Animatics SmartMotor. It also provides information on SmartMotor features and options, and where to find related documents and additional resources.

<b>SmartMotor Introduction</b> .....	<b>14</b>
<b>SmartMotor Features and Options</b> .....	<b>15</b>
Class 6 M-Style Motors .....	15
Standard Features .....	15
Optional Features .....	16
Connectors and LED Locations .....	16
Fieldbus Options .....	18
EtherCAT Fieldbus Protocol .....	18
PROFINET Fieldbus Protocol .....	18
EtherNet/IP Fieldbus Protocol .....	18
<b>SmartMotor Theory of Operation</b> .....	<b>19</b>

## SmartMotor Introduction

The Moog Animatics SmartMotor™ servo is an industrial servo motor with motion controller integrated into a compact package. Its design is based on these objectives:

1. Reduce development time
2. Lower machine-production cost
3. Simplify the machine (design, build and support)



*Class 6 M-Style MT SmartMotor (23-Frame)*



*Class 6 M-Style MT2 SmartMotor (34- and 23-Frame)*

The SmartMotor is powerful and unique because of its ability to control an entire machine. The combination of programmability, networking, I/O and servo performance is unmatched. The SmartMotor brings savings and value to the machine builder by removing complex and costly elements in the machine design, such as PLCs, sensors, I/O blocks, cabinets, etc.

## SmartMotor Features and Options

**NOTE:** All specifications are subject to change without notice. Consult the factory for the latest information.

All SmartMotors offer these features:

- Full floating-point math and trigonometric functions with 32-bit precision results
- Dual trajectory generators enabling relative and absolute position moves or velocity moves on top of gearing or camming
- Advanced gearing allowing preset traverse and take-up winding parameters including dwells and wrap counts
- Advanced camming including cubic spline interpolation and dynamic frequency and amplitude changes. Add onto gearing for complex traverse and take-up winding patterns.
- Stand-alone, multi-axis linear interpolation with as many as 120 SmartMotors at a time
- Virtual-axis control into camming through gearing, which enables stand-alone, multi-axis coordinated motion
- Programmable and non-programmable protection features (both hardware and software)

### ***A note about SmartMotor part numbers:***

The SmartMotor uses a coded part number, which contains characters that describe the motor number, frame style and options. For details on decoding the SmartMotor part number, refer to the Understanding SmartMotor Part Numbers document at this address:

<https://www.animatics.com/support/downloads.knowledgebase.html>

## Class 6 M-Style Motors

The Class 6 SmartMotor is available in an M-style configuration.

### Standard Features

All Class 6 M-style SmartMotors have these standard features:

- Two-port Industrial Ethernet (IE), IEEE 1588 capable, for extremely accurate motion synchronization
- LEDs: Bi-colored LED indicators to show error codes, provide network status and communications activity
- Communications: RS-485, micro USB, Combitronic over Ethernet (on properly configured motors, see Note) and Industrial Ethernet

**NOTE:** Combitronic over Ethernet requires the -EIP option Class 6 M-style SmartMotor with the netX 52 processor, NXF EIP version 3.4.0.5 or later, and SmartMotor firmware 6.0.2.35 or later.

- SMI software available, optionally used for application development and debugging
- I/O support for Drive Enable, Position Limits and Fault status
- Motor sample rate: 16 kHz
- Position Capture Register from signal-ended, ground-referenced external input (non-differential)

- External encoder input supporting either A-quadrant-B or Step-and-Direction modes of counting
  - Machine Line Shaft Input support
  - Maximum individual line frequency at either the A or B input is 1.5 MHz

All firmware options include:

- Modbus Remote Terminal Unit (RTU) Follower (RS-485 COM 0), see the *SmartMotor™ Modbus RTU Guide*
- DMX Follower (RS-485 COM 0), see the *SmartMotor™ DMX Guide*

## Optional Features

These features are only available on the MT2 Class 6 M-style SmartMotors:

- microSD card added on MT2 motors supports program storage and loading application-specific parameters
- Two outputs added on MT2 motors, 24V I/O connector, pins 5 and 6 (IN/OUT4 GP and IN/OUT5 GP, respectively)
- Internal brake is available on MT2 motors
- IP sealing is available on MT2 motors (IP level varies based on other options ordered)

These fieldbus communications protocols are available on the Class 6 motors. (Availability varies by model number; see the *Moog Animatics Product Catalog* for details.)

- EtherNet/IP (-EIP) option
- EtherCAT (-EEC) option
- PROFINET (-EPN) option

The Class 6 M-style motors are available in these NEMA frame sizes:

- NEMA 23 (MT and MT2)
- NEMA 34 (MT2 only)

For additional information on SmartMotor features, specifications, torque curves and more, see the corresponding SmartMotor product page for your motor. SmartMotor product pages are available from the Products menu on the Moog Animatics website.

## Connectors and LED Locations

The next figure shows the connector and LED location for the Class 6 M-style SmartMotor. Note that connector and LED positions are the same on MT and MT2 motors. For details on the motor connectors, see *Connecting the System* on page 30. For details on the LED functions, see *Understanding the Status LEDs* on page 37.

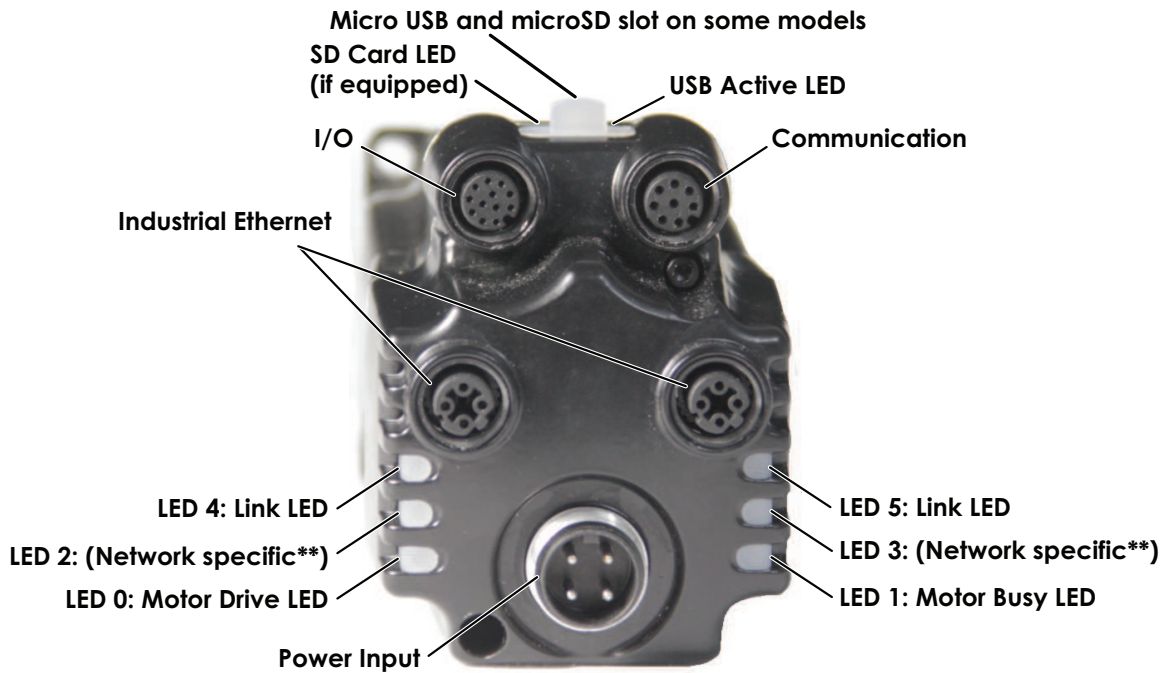

\*\*Refer to the Status LED description in the corresponding SmartMotor fieldbus guide

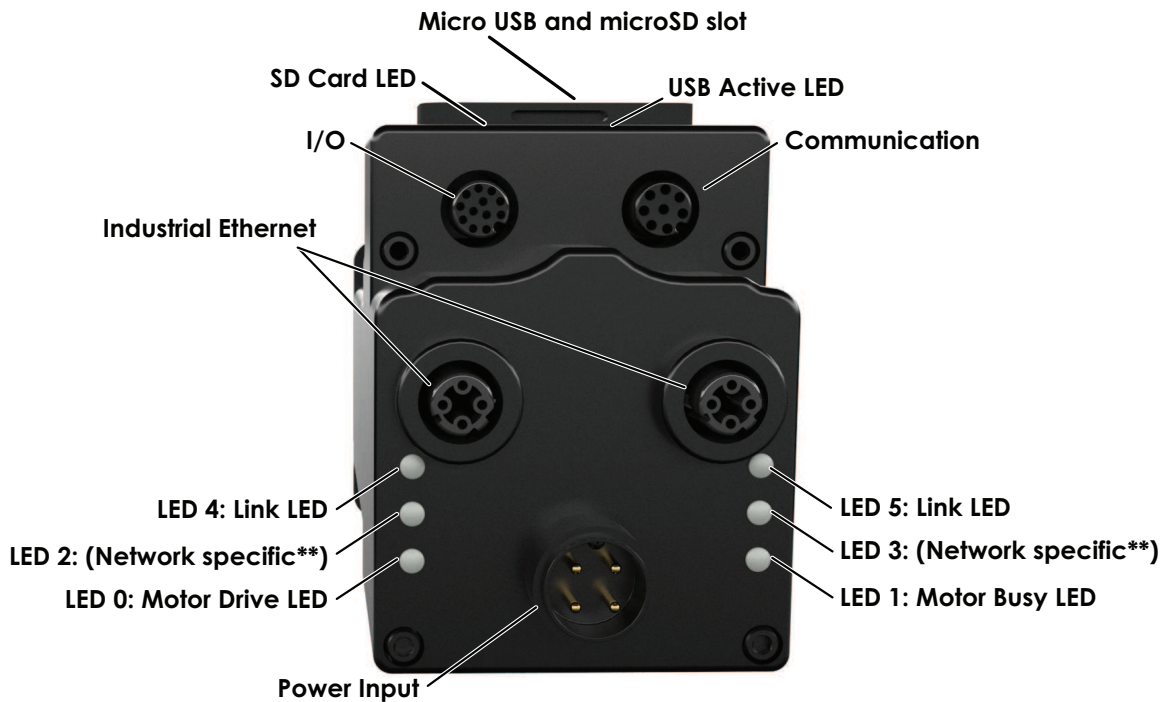

\*\*Refer to the Status LED description in the corresponding SmartMotor fieldbus guide

*Class 6 M-Style MT and MT2 SmartMotor Connectors and LEDs*



**CAUTION:** When daisy-chaining multiple SmartMotor servos for an EtherCAT network, you must connect the OUT port (right-hand port) of the upstream motor to the IN port (left-hand port) of the downstream motor.

## Fieldbus Options

This section details the Fieldbus communications protocol options that are available on SmartMotors.

### EtherCAT Fieldbus Protocol

**NOTE:** This fieldbus protocol is optionally available on Class 6 M-style motors.

The EtherCAT fieldbus protocol provides these features:

- Command/Response Codes for SmartMotor commands
- CiA 402 Motion Modes: Profile Position (PP), Profile Velocity (PV), Torque (TQ), Cyclic Sync Position (CSP), Cyclic Sync Velocity (CSV), Cyclic Sync Torque (CST)
- Dynamic PDO mapping
- Configurable Sync Manager 2 and 3 assignment
- DC-sync Subordinate mode with SYNC0 and SYNC1
- DC-sync follower
- Selectable Homing modes (with or without index pulse)
- Selectable Interpolation modes (spline or linear)
- Touch Probe function allows the motor's position to be captured on a specific event

For the EtherCAT connector diagram and pinouts, see *Connecting the System* on page 30.

For more details, see the *Class 6 SmartMotor EtherCAT Guide*.

### PROFINET Fieldbus Protocol

**NOTE:** This fieldbus protocol is optionally available on Class 6 M-style motors.

The PROFINET fieldbus protocol provides these features:

- Command/response codes for SmartMotor commands
- Use of on-board I/O through PROFINET, SmartMotor program, or RS-485 commands
- The Moog Animatics communications profile over PROFINET is intended to integrate well with a PLC that continuously transmits and receives cyclic data; the command and response codes achieve this through a handshaking mechanism

For the PROFINET connector diagram and pinouts, see *Connecting the System* on page 30.

For more details, see the *Class 6 SmartMotor™ PROFINET Guide*.

### EtherNet/IP Fieldbus Protocol

**NOTE:** This fieldbus protocol is optionally available on Class 6 M-style motors.

The EtherNet/IP fieldbus protocol provides these features:

- Access to unique SmartMotor commands and parameters.
- Use of on-board I/O through EtherNet/IP, SmartMotor program, or RS-485 commands

- The Moog Animatics communications profile over EtherNet/IP is intended to integrate well with a PLC that continuously transmits and receives cyclic data (implicit messaging); the command and response codes achieve this through a handshaking mechanism
- Certain configuration data is held in nonvolatile storage in the SmartMotor; therefore, the motor data EEPROM must be correctly initialized before EtherNet/IP operation
- Supports extended function CIP Position Controller Device
- Supports Combitronic over Ethernet
  - NOTE:** Combitronic over Ethernet requires the -EIP option Class 6 M-style SmartMotor with the netX 52 processor, NXF EIP version 3.4.0.5 or later, and SmartMotor firmware 6.0.2.35 or later.
- Supports Modbus TCP/IP, see the *Class 6 SmartMotor™ Modbus TCP/IP Guide*
- Supports Ethernet Serial Encapsulation, see the *Class 6 SmartMotor Ethernet Serial Encapsulation Guide*
- Control modes for Profile Torque, Profile Velocity and Profile Position modes
- Change Dynamic - motion profile changes on the fly
- Implicit exchange access to many SmartMotor parameters
- Supports the SMI software Find/Detect operations over Ethernet – the SmartMotor must be previously configured (through COM or USB) with a valid IP address

For the EtherNet/IP connector diagram and pinouts, see Connecting the System on page 30.

For more details, see the *Class 6 SmartMotor EtherNet/IP Guide*.

## SmartMotor Theory of Operation

The Moog Animatics SmartMotor is an entire servo control system built inside of a servo motor. It includes a controller, an amplifier and an encoder. All that is required for it to operate is power and either an internal program or serial commands from outside (or both). To make the SmartMotor move, the program or serial host must set a mode of operation, state a target position with/or a maximum velocity at which to travel to that target, and a maximum acceleration. After these three parameters are set, the two limit inputs are pulled high or deactivated, and the Drive Enable input is satisfied, a "Go" command starts the motion profile.

The core functional areas of the SmartMotor are:

- Motion Control Functions (see Motion Details in the *SmartMotor™ Developer's Guide*)
- System Control Functions (see Program Flow Details and see System Status in the *SmartMotor™ Developer's Guide*)
- Communication Functions (see Communication Details in the *SmartMotor™ Developer's Guide*)
- I/O Functions (see I/O Control in the *SmartMotor™ Developer's Guide*)

The next block diagram illustrates the relationship between the functional areas in the SmartMotor.

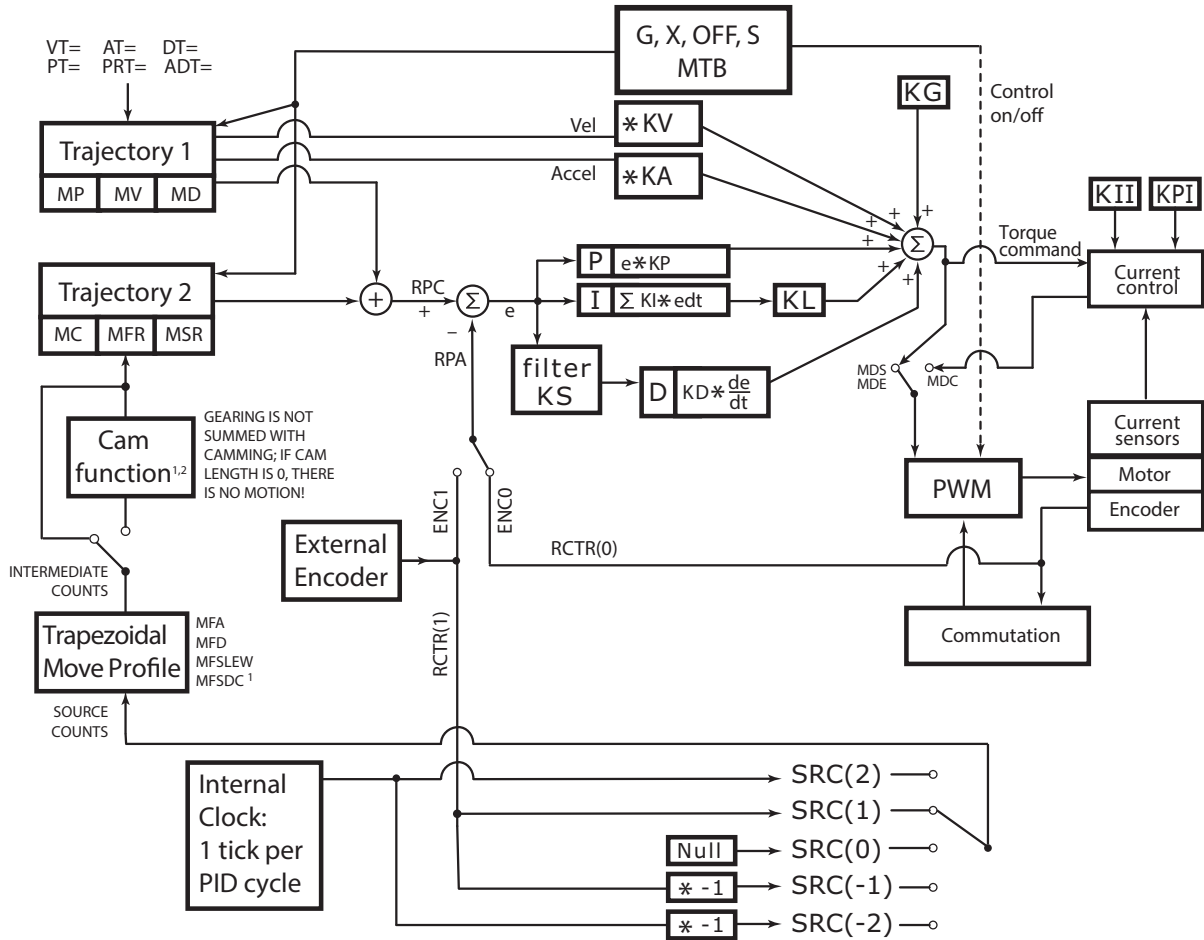

NOTES:

1. MFMUL and MFDIV commands do not have an effect on dwell time or distance. Dwell is strictly based on raw controller encoder counts selected by the SRC() command specifying internal virtual or external controller count source.
2. When feeding a Cam table with a gearing profile, changes to MFMUL and MFDIV will affect the time it takes to move through a Cam table but will not affect dwell time, as specified in the previous note.

SmartMotor Theory of Operation Diagram

# Getting Started

This chapter provides information on getting started with your SmartMotor.

<b>Unpacking and Verifying Your Shipment</b> .....	<b>23</b>
<b>Installing the SMI Software</b> .....	<b>23</b>
Installation Procedure .....	23
Installation Verification .....	26
<b>Accessing the SMI Software Interface</b> .....	<b>26</b>
<b>Understanding the Power Requirements</b> .....	<b>28</b>
SmartMotor Power Requirements .....	28
CPU, I/O and Communications Power .....	28
CPU Power Requirements .....	28
I/O Power Requirements .....	29
Communications Power Requirements .....	29
Drive Enable Input .....	29
<b>Connecting the System</b> .....	<b>30</b>
Minimum Requirements .....	30
Motor Connectors and Pinouts .....	31
Power and RS-485 Com Multidrop .....	32
USB Connector and Cable .....	32
Industrial Ethernet Network .....	34
Min and Max Cable Length .....	35
Moog Animatics Industrial Ethernet Cables .....	35
M-style to M-style Ethernet Cable .....	35
M-style to RJ45 Ethernet Cable .....	35
Ethernet Cable Schematic .....	36
<b>Understanding the Status LEDs</b> .....	<b>37</b>
Status LEDs .....	37
<b>Understanding the SD Card</b> .....	<b>38</b>
SD Card Location and LED Indicator .....	38
SD Card Requirements .....	38
SD Card Configuration .....	39
SD Card Operation .....	39
SD Card Status Bits .....	39
<b>Detecting and Communicating with the SmartMotors</b> .....	<b>40</b>
Understanding the Detection and Configuration Options .....	40

Using the Find Motors Button .....	40
Using the Detect Motors Feature .....	43
<b>Checking and Clearing the Status Bits .....</b>	<b>45</b>
Polling the Motor .....	46
Clearing the Overtravel Limits and Fault Bits .....	47
<b>Moving the SmartMotor .....</b>	<b>48</b>
Making the Motor Move .....	48
Setting and Reporting Torque .....	49
<b>Checking the Motor Position .....</b>	<b>50</b>
Viewing the Motor Position with a Report Command .....	50
Viewing the Motor Position with the Motor View Tool .....	50

## Unpacking and Verifying Your Shipment

Your Moog Animatics SmartMotor and accessories are carefully assembled, tested, inspected and packed at the factory.

When you receive your shipment, you should:

- Visually inspect all shipping containers for visible signs of shipping damage. If you see damage, please notify your carrier and then contact Moog Animatics to report the problem.
- Carefully unpack each component and verify the part number with your order. If there are any differences or missing items, please contact Moog Animatics so that the shipment can be corrected.
- Keep all boxes and packing materials. These may be needed for future storage or shipment of the equipment.

## Installing the SMI Software

The SmartMotor Interface software (SMI software) provides a convenient user interface for programming the SmartMotor. Before you can use the SMI software, it must be installed on a Microsoft Windows PC.

The SMI software is distributed on CD-ROM or USB stick, and is also available as a download from the Moog Animatics website. To download the latest version of the SMI software, use this address:

<http://www.animatics.com/smi>

Then scroll to the bottom of the page and click the Free Download button.

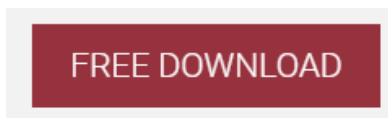

*SMI Download Button*

The installation package is downloaded to your system.

**NOTE:** The SMI software requires Microsoft Windows XP or later.

### Installation Procedure

**NOTE:** Depending on the SMI software version and SmartMotor model being used, the software version and motor information may be different on your screens.

To install the SMI software:

1. Double-click the executable package (.MSI) file to begin the installation. In some versions of Microsoft Windows, you may receive a security warning message about running the file. You can ignore this message.

If this is a new installation, go to the next step.

If this is an upgrade to a previous installation, you will see the window below. Select Remove, click Next and remove the existing software from your PC using the instructions.

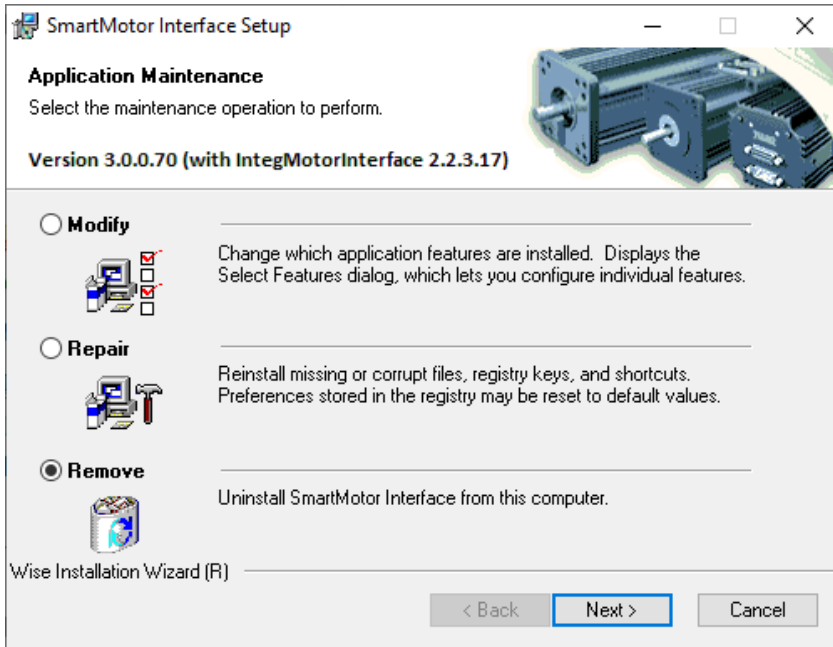

After removing the existing software, restart the installation process.

**NOTE:** All personal settings and user files will be retained.

2. Click Next to proceed. The Installation Configuration page opens.

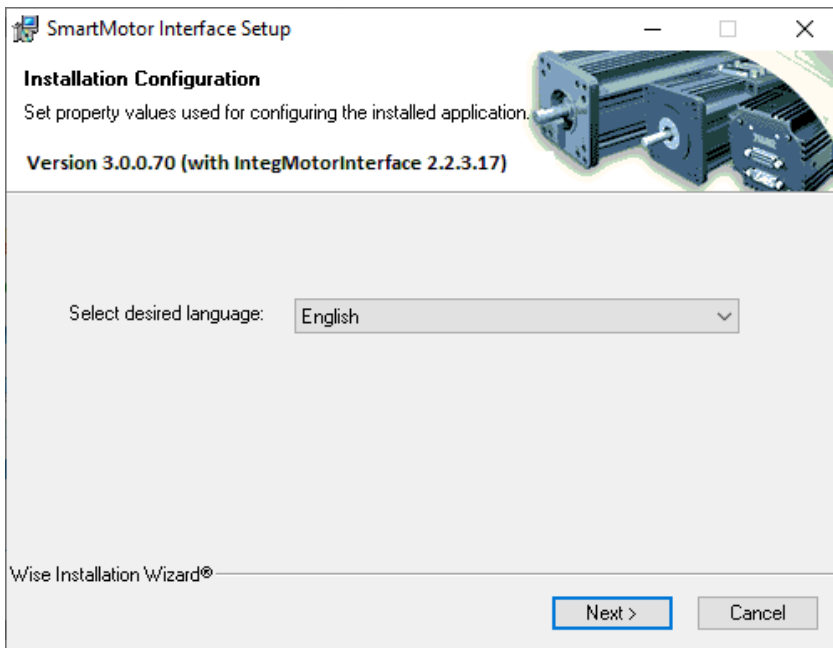

3. Click Next to proceed. The SMI software installation wizard starts and the Welcome page opens.

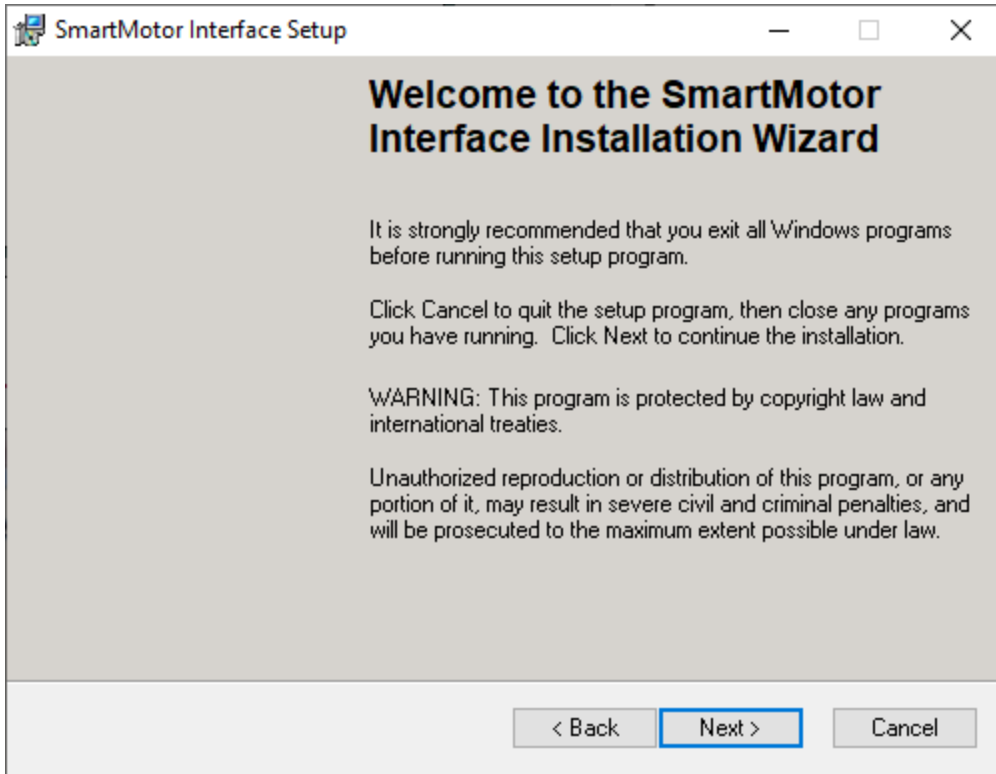

4. After you have finished reviewing the welcome information, click Next to proceed. Use the on-screen instructions to complete the SMI software installation.

- When the installation has completed, the installation status message page opens, as shown in the next figure. Click Finish to complete the installation and close the installation wizard.

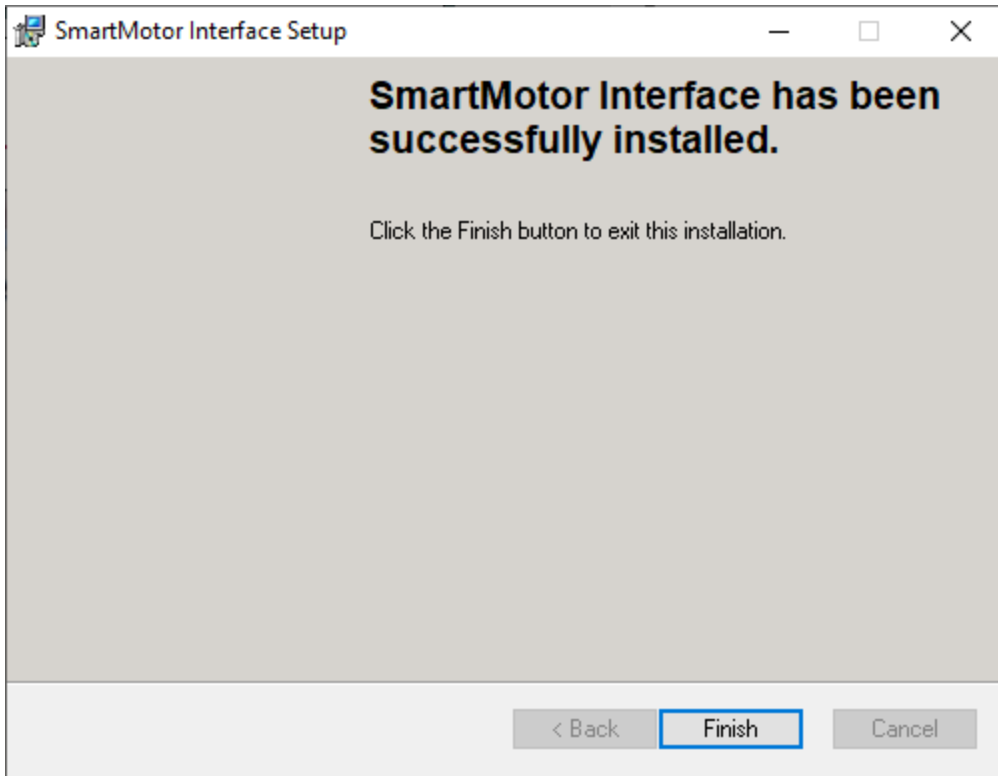

**NOTE:** After the software is installed, be sure to restart your computer before running the SMI software.

## Installation Verification

To verify the installation, navigate to the C:\Program Files (or folder C:\Program Files x86) folder. You should see these folders:

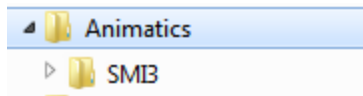

## Accessing the SMI Software Interface

The SmartMotor Interface software (SMI software) communicates with a single or series of SmartMotors from a Windows-based PC and gives you the capability to control and monitor the status of the motors. The SMI software also allows you to write programs and download them into the SmartMotor's long-term memory.

**NOTE:** Every SmartMotor has an ASCII interpreter built in. Therefore, it is not necessary to use the SMI software to operate a SmartMotor.

To open the SMI software, double-click the SmartMotor Interface shortcut on the Windows desktop.



*SmartMotor Interface Shortcut*

Optionally, to open the SMI software from the Microsoft Windows Start menu, select:

**Start > All Programs > Animatics > SMI3 > SmartMotor Interface**

The SMI software interface opens, as shown in the next figure.

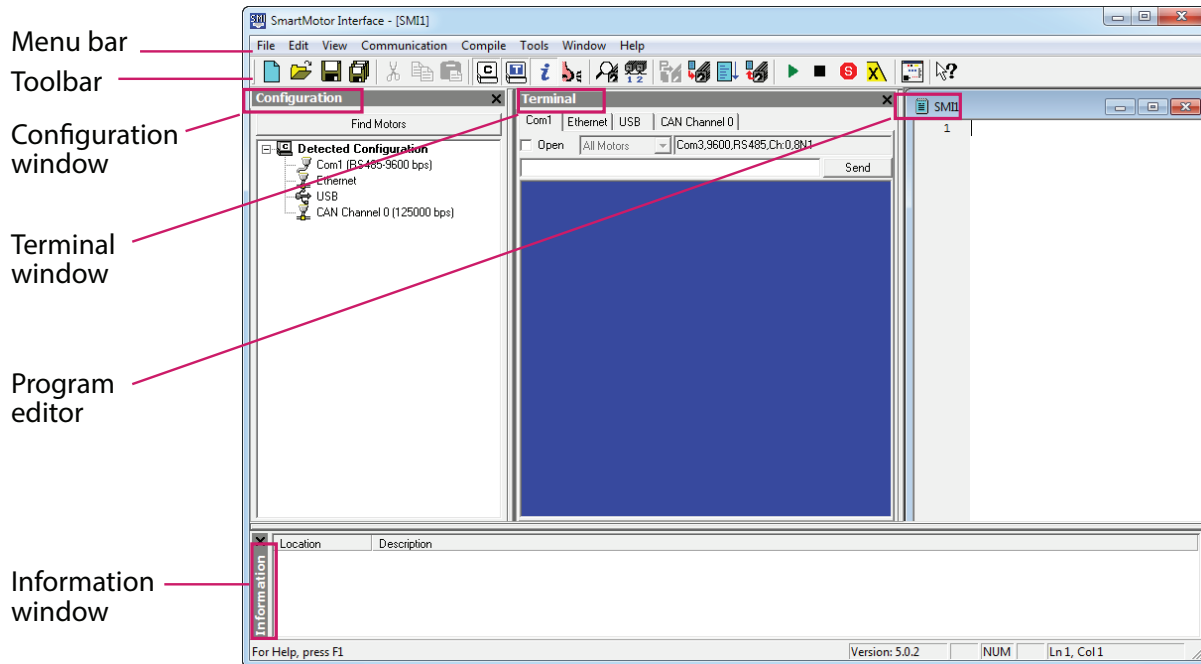

*SMI Software Interface*

**NOTE:** In addition to the software information in this section, there is context-sensitive help available within the SMI software interface, which is accessed by pressing the F1 key or selecting Help from the SMI software main menu.

These are the primary features in this interface:

- **Menu Bar:** All of the windows and functions of the SMI software can be accessed through the menu bar. Many of these are also accessible through the icons on the toolbar.
- **Toolbar:** The toolbar contains a collection of icons for accessing the primary features of the SMI software. Depending on the current state of the SMI software and the currently-active window, some toolbar buttons may be disabled.
- **Configuration Window (far-left window):** This window is used to display the current communication and detected motor configuration when no project is open, or the communication and motor configuration defined in an open project.
- **Terminal Window (middle window):** This window is used to communicate with SmartMotors (for example, issue single-line commands to one or all motors). The response (if any) is also shown in this window.
- **Information Window (lower window):** This window is used to display the results of user operations.
- **Program Editor (far-right window):** This window is used to manage, edit and print user programs. Most of the procedures for using the editor should seem familiar if you have used other Windows-based text editors.

For more details about these items, see the SMI software online help, which can be viewed in SMI by pressing F1 or selecting Help > Contents - SMI Software Help.

## Understanding the Power Requirements

This section describes the power requirements for Class 6 M-style SmartMotor power, CPU power, I/O power and Communications power.

### SmartMotor Power Requirements

---



**CAUTION:** If power is reversed on any standard SmartMotor, immediate damage WILL occur and the SmartMotor will no longer operate.

---

#### **Requirement:**

For Class 6 M-style SmartMotors:

---



**CAUTION:** Control power for Class 6 M-style motors must be nominal 24 VDC ( $\pm 20\%$ ). They are not rated for 48 VDC.

---

Control power requires nominal 24 VDC ( $\pm 20\%$ ), do not exceed 32 VDC; motor power requires from 24 VDC to 48 VDC, do not exceed 48 VDC.

**Details:** Large SmartMotors can draw high current. Therefore, heavy gauge wire is required to connect the large motors.

Voltages below 18 VDC could cause a brownout shutdown of the CPU, or what would appear as a power-off reset, under sudden load changes.

When relying on torque/speed curves, pay close attention to the voltage on which they are based.

During hard, fast decelerations, a SmartMotor can pull up supply voltages to the point of damage if a shunt resistor pack is not used. Protective shunts are available from Moog Animatics.

---



**CAUTION:** Many vertical applications and applications with hard, fast decelerations require shunts to protect the SmartMotor from damage. Note that shunts should always be placed between the motor input and any disconnect or E-stop relay to protect the motor when power is off or E-stop relay contacts are open.

---

Special care must be taken when near the upper voltage limit or in vertical applications that can back-drive the SmartMotor. Gravity-influenced applications can turn the SmartMotor into a generator and back-drive the power supply voltage above the safe limit for the SmartMotor. Many vertical applications require a shunt to protect the SmartMotor from damage. Protective shunts are available from Moog Animatics.

### CPU, I/O and Communications Power

---



**CAUTION:** The maximum allowed supply voltage is 32 VDC. Voltages greater than the maximum value will damage the equipment.

---

#### CPU Power Requirements

**Requirement:** Nominal 24 VDC ( $\pm 20\%$ ) must be supplied. Do not exceed 32 VDC.

**Details:** Power is supplied from the "control" power input (pin 1) on the 4-pin power input connector.

## I/O Power Requirements

**Requirement:** Nominal 24 VDC ( $\pm 20\%$ ) must be supplied. Do not exceed 32 VDC.

**Details:** Power is supplied from the "control" power input (pin 1) on the 4-pin power input connector.

**NOTE:** This I/O is not isolated from the CPU's power supply and the motor drive.

24 VDC Control/I/O output power is provided on pin 11 and supports a maximum of 2 amps. That pin is directly connected to Pin 1 of the power input connector. Refer to Motor Connectors and Pinouts on page 31.

### **Specifications:**

**NOTE:** All specifications assume nominal 24 VDC ( $\pm 20\%$ ) Control power. The maximum allowed supply voltage is 32 VDC. Voltages greater than the maximum value will damage the motor.

#### Input Pins Electrical Specification:

- Input Voltage Low Level Threshold: 3.6 V maximum
- Input Voltage High Level Threshold: 5.0 V minimum
- Input Hysteresis Voltage: 1.0 V minimum

#### Output Pins Electrical Specification:

- Output Loading:
  - Nominal load: 250 mA each
  - Maximum load: not to exceed 500 mA total (all outputs combined)
- Output voltage: 23 V maximum load

## Communications Power Requirements

**Requirement:** Nominal 24 VDC ( $\pm 20\%$ ) must be supplied. Do not exceed 32 VDC.

**Details:** Power is supplied from the "control" power input (pin 1) on the 4-pin power input connector.

**NOTE:** The RS-485 signal is not isolated from the CPU's power supply or the motor drive.

## Drive Enable Input

The Drive Enable input (P3, pin 8) must be connected and activated with 24V. For the input location, see Motor Connectors and Pinouts on page 31.

## Connecting the System

The next sections show system connections and cable diagrams for typical installations. For connector specifications and example I/O connections, see Connectors, Pinouts and Examples on page 52.

### Minimum Requirements

At minimum, you will need these items:

1. A Class 6 M-style SmartMotor
2. A computer running Microsoft Windows and the SMI software
3. An I/O cable used to satisfy the Drive Enable input and position limits.
4. A DC power supply and power cable for the SmartMotor
5. A data cable to connect from the computer to the SmartMotor using one of these:
  - Serial port (or serial adapter)
  - USB port
  - Ethernet port

Refer to the next sections for more details.

## Motor Connectors and Pinouts

The next figure provides an overview of the connectors and pinouts available on the Class 6 SmartMotor. Note that connector and LED positions are the same on MT and MT2 motors. Additional connector specs are shown in Class 6 M-Style Connector Pinouts on page 53.

**NOTE:** In the next figure, I/O pins 5 and 6 OUTPUTS apply to MT2 motors only.

I/Os				
PIN	FUNCTION	INPUT OR OUTPUT	POSSIBLE (SELECTABLE) FUNCTIONS	DEFAULT
1	IN0	INPUT	GENERAL PURPOSE, ALSO ANALOG	GENERAL PURPOSE
2	IN1	INPUT	GENERAL PURPOSE, ALSO ANALOG	GENERAL PURPOSE
3	IN2/POSLIMIT	INPUT	POSITIVE LIMIT OR GENERAL PURPOSE	POSITIVE LIMIT
4	IN3/NEGLIMIT	INPUT	NEGATIVE LIMIT OR GENERAL PURPOSE	NEGATIVE LIMIT
5	IN/OUT4	INPUT/OUTPUT	GENERAL PURPOSE, OR EXTERNAL ENCODER INDEX CAPTURE	GENERAL PURPOSE
6	IN/OUT5	INPUT/OUTPUT	GENERAL PURPOSE, OR INTERNAL ENCODER INDEX CAPTURE	GENERAL PURPOSE
7	IN6	INPUT	GENERAL PURPOSE, G COMMAND, OR HOMING INPUT	GENERAL PURPOSE
8	IN7-DRVEN	INPUT	DRIVE ENABLE	DRIVE ENABLE
9	OUT8/BRAKE	OUTPUT	BRAKE OUTPUT OR GENERAL-PURPOSE OUTPUT	BRAKE OUTPUT
10	OUT9-NOFAULT	OUTPUT	NOT FAULT	NOT FAULT
11	24 VDC OUT*	POWER OUTPUT**	CONTROL I/O POWER	CONTROL I/O POWER
12	GND	N/A	N/A	MOTOR COMMON GROUND

\*NOTE: 2 AMPS MAX \*\*SUPPLIED FROM POWER INPUT PIN 1

**EtherCAT\***

PIN	FUNCTION
1	+TX
2	+RX
3	-TX
4	-RX

**EtherNet/IP**

PIN	FUNCTION
1	+TX
2	+RX
3	-TX
4	-RX

**PROFINET**

PIN	FUNCTION
1	+TD
2	+RD
3	-TD
4	-RD

Shield tied to motor housing

**COMMUNICATION**

PIN	FUNCTION
1	GND-COMMON
2	RS-485B CH0
3	RS-485A CH0
4	ENC A+ (IN/OUT)
5	ENC B- (IN/OUT)
6	ENC A- (IN/OUT)
7	5 VDC OUT
8	ENC B+ (IN/OUT)

RS-485 serial communication uses a voltage differential signal. Appropriate terminating resistors should be included on the RS-485 network to ensure reliable performance. For details, see the section Power and RS-485 Com Multidrop.

**POWER INPUT**

PIN	FUNCTION	DESCRIPTION
1	24 VDC	CONTROL I/O POWER
2	EARTH	CHASSIS GROUND
3	GND	MOTOR COMMON GROUND
4	48 VDC	MOTOR POWER

\*The Input/Output applies to these networks. Refer to the following CAUTIONS.  
 \*\*For LED Status information, refer to the corresponding SmartMotor fieldbus guide.

**CAUTION:** M-style connectors must be finger tightened only! DO NOT use a wrench or other tool. Doing so can cause overtightening of the connection, which may damage the connector and will void the warranty.

**CAUTION:** When daisy-chaining SmartMotors for an EtherCAT network, you must connect the Output port (right-hand port) of the upstream motor to the Input port (left-hand port) of the downstream motor. For more details, see Connecting the System on page 30.

## Power and RS-485 Com Multidrop

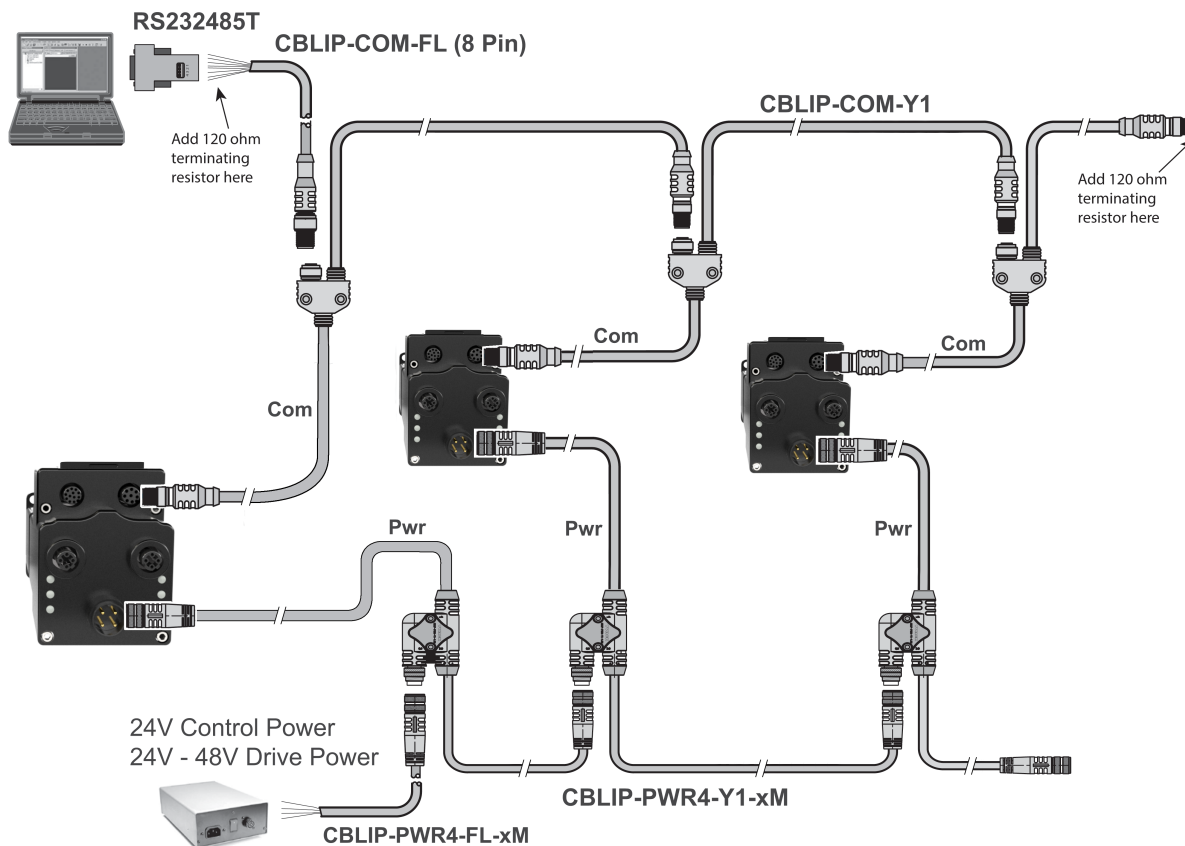

**NOTE:** RS-485 serial communications uses a voltage differential signal that requires proper termination with a 120 ohm resistor across pins 2 and 3 at both ends of the network cable. This complies with RS-485 standards for biasing to ensure reliable performance. The termination can be created by adding the resistor to CBLIP-COM-FL Flying Lead cables or to off-the-shelf connectors.

## USB Connector and Cable

As shown in following figure, there is a micro USB (micro-B) connector located under a protective cover on top of the motor. An LED indicator is also provided, which shows the status/activity for that connector.



**CAUTION:** For -IP option (IP sealed) motors, whenever the micro USB/SD cover is removed, the seal must be inspected and the cover must be reinstalled without damaging the seal in order to maintain the integrity of the sealed motor.



*Micro USB Connector Located Under Protective Cover  
(34-frame on left, 23-frame on right)*

**NOTE:** To keep dust and debris out of the port, always replace the protective cover when the micro USB connector is not in use.

A micro-B USB cable is a standard type of USB cable that can be obtained from most computer or electronics supply stores. Typically, this cable is referred to as a "micro USB" cable.



*Micro USB Cable*

**NOTE:** Be aware that some micro USB cables have a thicker plastic molding that may interfere with the motor housing.

The next figure shows the SmartMotor connected to a PC through the USB ports on both devices.

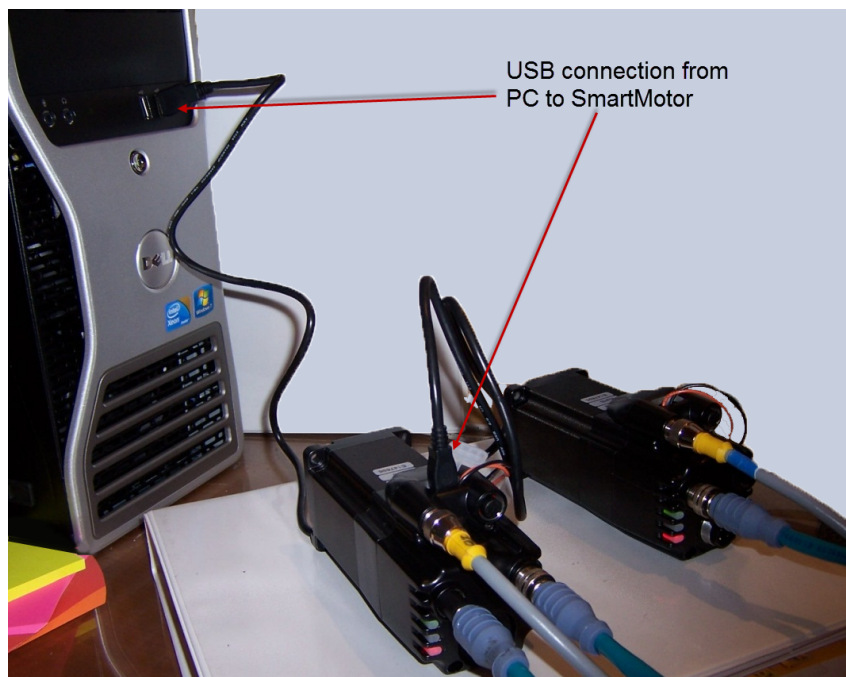

USB Connection from PC to SmartMotor

## Industrial Ethernet Network

**NOTE:** If you have set your PC's network adapter to a fixed IP address for temporary connections to SmartMotors with SMI, remember to return it to DHCP when done to avoid local area network connectivity issues.

The Industrial Ethernet network is used for the EtherCAT (-EEC), EtherNet/IP (-EIP) and PROFINET (-EPN) options. Most Industrial Ethernet (IE) networks support line, tree or star device-connection topology. Tree or star network may require switches/hubs designed for that network type. Requirements for specific configurations depend on the capabilities of the controller device, the follower devices, and use of other networking equipment. For more details, refer to the corresponding SmartMotor fieldbus manual.



**CAUTION:** To minimize the possibility of electromagnetic interference (EMI), all connections should use *shielded* Ethernet Category 5 (Cat 5), or better, cables. All interconnecting cables in the daisy chain and/or ring configuration for Industrial Ethernet must have a length of at least 1 meter (3.28 feet).

The next diagram shows an example Industrial Ethernet network with the SmartMotors daisy chained to the controller device. A "ring" configuration can be created if the controller device has two ports.



**CAUTION:** When daisy-chaining SmartMotors for an EtherCAT network, you must connect the OUT port (right-hand port) of the upstream motor to the IN port (left-hand port) of the downstream motor. Refer to the Ethernet ports labeling on your SmartMotor.

---

## Industrial Ethernet Network

Optional ring for cable redundancy\*\*

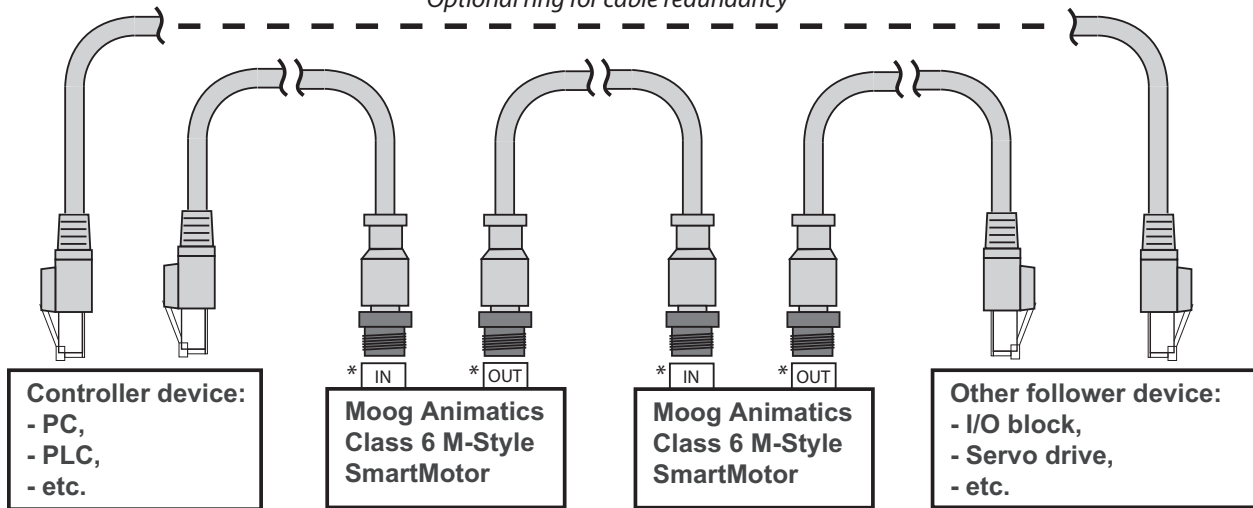

\*IN/OUT applies only to EtherCAT networks. Refer to the previous CAUTION and motor labeling.

\*\*Ring configuration requires a controller device with two ports

### Min and Max Cable Length

The minimum shielded Ethernet Cat 5 cable length between network nodes must be 1 meter.

For transmission speeds of 100 Megabits/second on shielded Ethernet Cat 5 cable, most Industrial Ethernet networks allow a maximum cable length up to 100 meters between network nodes.

### Moog Animatics Industrial Ethernet Cables

The next Industrial Ethernet cables are available from Moog Animatics.

#### M-style to M-style Ethernet Cable

This cable has M12 male threaded connectors at both ends. It is available in 1, 3, and 5 meter lengths. For the standard cable, use part number CBLIP-ETH-MM-xM, where "x" denotes the cable length. A right-angle version may available for certain lengths; see the Moog Animatics website for details.

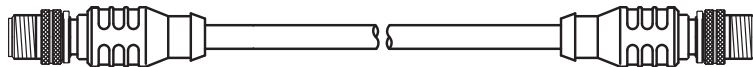

#### M-style to RJ45 Ethernet Cable

This cable has an M12 male threaded connector at one end, and an RJ45 male connector at the opposite end. It is available in 1, 3, and 5 meter lengths. For the standard cable, use part number CBLIP-ETH-MRJ-xM, where "x" denotes the cable length. See the Moog Animatics website for details.

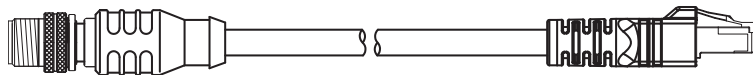

### Ethernet Cable Schematic

The next figure provides details for creating a custom Industrial Ethernet shielded cable.

**NOTE:** The motor end of the cable requires an industrial Ethernet connector.

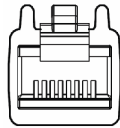
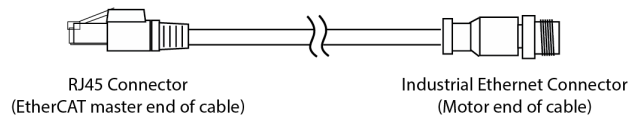

1 2 3 4 5 6 7 8

PIN	DESCRIPTION
1	+TX
2	-TX
3	+RX
4	No Connection
5	No Connection
6	-RX
7	No Connection
8	No Connection
Shield tied to RJ45 connector	

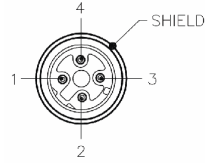

PIN	DESCRIPTION
1	+TX
2	+RX
3	-TX
4	-RX
Shield tied to motor housing	

## Understanding the Status LEDs

This section describes the functionality of the status LEDs on the Class 6 SmartMotor.

### Status LEDs

The next figure and tables describe the functionality of the Status LEDs on the SmartMotor. Refer to the corresponding SmartMotor fieldbus guide for the functions of the network-specific LEDs.

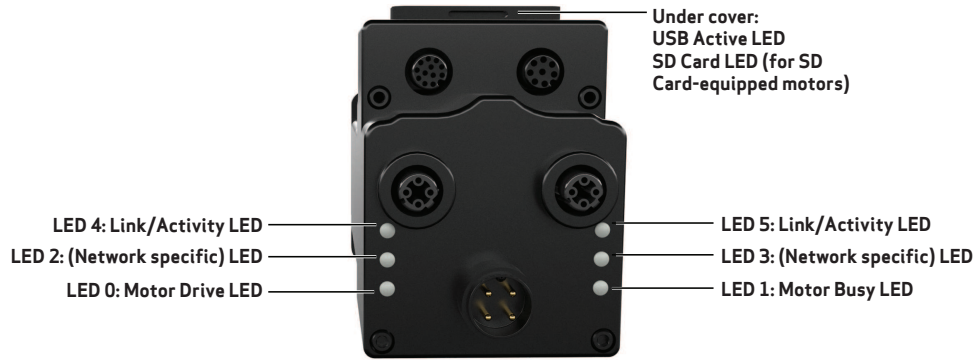

SD Card LED (for SD Card-equipped motors)

Off	No card, bad or damaged card
Blinking green	Busy, do not remove card
Solid green	Card detected
Solid red	Card with no SmartMotor data

See the topic "Understanding the SD Card" for details.

USB Active LED

Flashing green	Active
Flashing red	Suspended
Solid red	USB power detected, no configuration

If the USB port is plugged in at power up, it flashes for ~4 seconds, turns solid red until it is detected through SMI, then it returns to flashing

LED 0: Motor Drive LED

Off	No power
Solid green	Drive on
Blinking green	Drive off, no faults
Triple red flash	Watchdog fault
Solid red	Faulted or no drive enable input
Alt. red/green	In boot load; needs firmware

LED 1: Motor Busy LED

Off	Not busy
Solid green	Drive on, trajectory in progress
Flashing # red	Flashes fault code (see below) when Drive LED is solid red

**Fault Codes:** pauses for 2 sec before flashing the code

Flash	Description
1	NOT Used
2	Bus Voltage
3	Over Current
4	Excessive Temperature
5	Excessive Position
6	Velocity Limit
7	dE/Dt - First derivative of position error is excessive
8	Hardware Positive Limit Reached
9	Hardware Negative Limit Reached
10	Software Positive Travel Limit Reached
11	Software Negative Travel Limit Reached

**LED 0 and 1 Status on Power-up:**

- With no program and the travel limit inputs are low:  
LED 0 solid red; motor in fault state due to travel limit fault  
LED 1 off
- With no program and the travel limits are high:  
LED 0 solid red for 500 milliseconds then flashing green  
LED 1 off
- With a program that only disables travel limits:  
LED 0 red for 500 milliseconds then flashing green  
LED 1 off

LED 2: (Network specific) LED  
Refer to the corresponding SmartMotor fieldbus guide

LED 4: Link/Activity LED

Off	No/bad cable; no/bad Link port
Solid green	Link established
Blinking green	Activity

LED 3: (Network specific) LED  
Refer to the corresponding SmartMotor fieldbus guide

LED 5: Link/Activity LED

Off	No/bad cable; no/bad Link port
Solid green	Link established
Blinking green	Activity

## Understanding the SD Card

Class 6 MT2 SmartMotor servos are equipped with a microSD card slot. This feature allows the user to insert a microSD card into the motor, which will then be available for storage of programs, program parameters, motor configuration, etc.

The remainder of this section discusses specific features and requirements of the microSD card.

### SD Card Location and LED Indicator

When viewing the motor from the rear (connector end), the microSD card slot is on top of the motor under the cover, and the corresponding LED is located on the left side under the cover.



**CAUTION:** For -IP option (IP sealed) motors, whenever the micro USB/SD cover is removed, the seal must be inspected and the cover must be reinstalled without damaging the seal in order to maintain the integrity of the sealed motor.

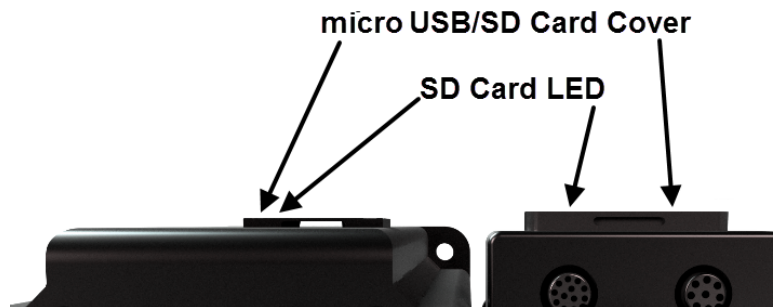

*34-Frame (on left) and 23-Frame (on right)  
SD Card and LED Location*

LED State	Meaning
Off	No card, bad card format or damaged card
Green blinking	Busy, do not remove card
Green solid	Card detected
Red solid	Card with no SmartMotor data

### SD Card Requirements



**CAUTION:** All microSD card data must be backed up to a secure storage device. Moog Animatics is not responsible for loss of data.

The SD card has these requirements:

- Form factor must be a microSD type
- HC and SC cards up to 1 GB are supported
  - SC cards over 1 GB are not supported
- Cards should be Class 2 speed or higher

- Cards must be formatted as Microsoft FAT file system or Microsoft FAT32 file system
- Only SmartMotor files should be placed on the microSD card; all files must be placed in the root folder

## SD Card Configuration

For configuration information, see the topic SD Card Setup in the SMI software online help.

## SD Card Operation

---



**CAUTION:**

- 1, Do not insert or remove the card while the motor is powered up. Doing so could corrupt the card or the motor's internal EEPROM storage.
  2. The file name "program.tmp" is reserved for temporary use. Do not use this file name on the card.
- 

At start-up time, the motor inspects the microSD card to find the user program executable file. The motor compares the program on the card to the program stored in the motor. If they differ, then the program is copied to the motor replacing the program in the motor. After the program is copied to the motor, the program runs like it would on non-microSD-card motors.

If there was no change because the version on the card matched the version in the motor, the program will also be run from the motor. Note that:

- Multiple smx files may exist on the card.
- The motor requires that "pointer.txt" exists in the root directory of the card. "pointer.txt" contains a single line of text with the full file name of the program to run at start-up.

At this time, support for user-configured parameters is limited to SNAME and IDENT, which are stored on the microSD card as the file "param.ee" in the root of the card's file system. If this file is present on the card, the user configuration parameter area in the motor's internal EEPROM is written with the data from the microSD card. Note that:

- Network name (SNAME command) saves to the microSD card if it is present.
- IDENT= saves to the microSD card if card is present; RIDENT can report this value; x=IDENT can recall this value. IDENT is stored as a 32-bit signed value with a default of -1.

## SD Card Status Bits

For information on the SD card status bits, see the *SmartMotor™ Developer's Guide*.

## Detecting and Communicating with the SmartMotors

**NOTE:** Depending on the SMI software version and SmartMotor model being used, the software version and motor information may be different on your screens.

This section describes how to detect and address the Class 6 SmartMotor.

This procedure assumes that:

- The SmartMotor is connected to the computer. For details, see *Connecting the System* on page 30.
- The SmartMotor is connected to a power source. For details, see *Understanding the Power Requirements* on page 28 and *Connecting the System* on page 30.
- The SMI software has been installed and is running on the computer. For details, see *Installing the SMI Software* on page 23.

### Understanding the Detection and Configuration Options

**NOTE:** This feature requires connection to the serial (COM) port, configured as RS-485, or the USB port. EtherNet/IP motors also support the SMI software Find/Detect operations over Ethernet – the SmartMotor must be previously configured (through COM or USB) with a valid IP address. There is no support for EtherCAT or PROFINET detection.

There are several ways to use the SMI software to find and address the Class 6 M-style SmartMotors that are connected to your PC:

- Use the Find Motors button—this method is recommended for first-time communications or when you don't know the port used to connect the motors. For details, see *Using the Find Motors Button* on page 40.
- Use the Detect Motors feature—this method can be used if you know the communications port used to connect your motors and if your motors may be pre-addressed. For details, see *Using the Detect Motors Feature* on page 43.
- To set up your motor to communicate over an Industrial Ethernet (IE) network refer to the corresponding fieldbus protocol guide.

Several of these methods are described in the next sections.

### Using the Find Motors Button

**NOTE:** For non-EIP motors, Class 6 currently supports SMI Find/Detect operations on RS-485 and USB connections only. EIP motors additionally support the SMI software Find/Detect operations over Ethernet – the SmartMotor must be previously configured (through COM or USB) with a valid IP address.

The easiest way to locate any connected SmartMotor is to use the Find Motors button (see the next figure). This method searches all ports on the PC for connected motors.

To begin searching for motors on the PC, in the Configuration window of the SMI software interface, click Find Motors. The SMI software begins searching for all SmartMotors connected to the PC.

**NOTE:** The next figures show examples for an RS-485 SmartMotor. To see similar example figures for USB motors, refer to *Using the Detect Motors Feature* on page 43.

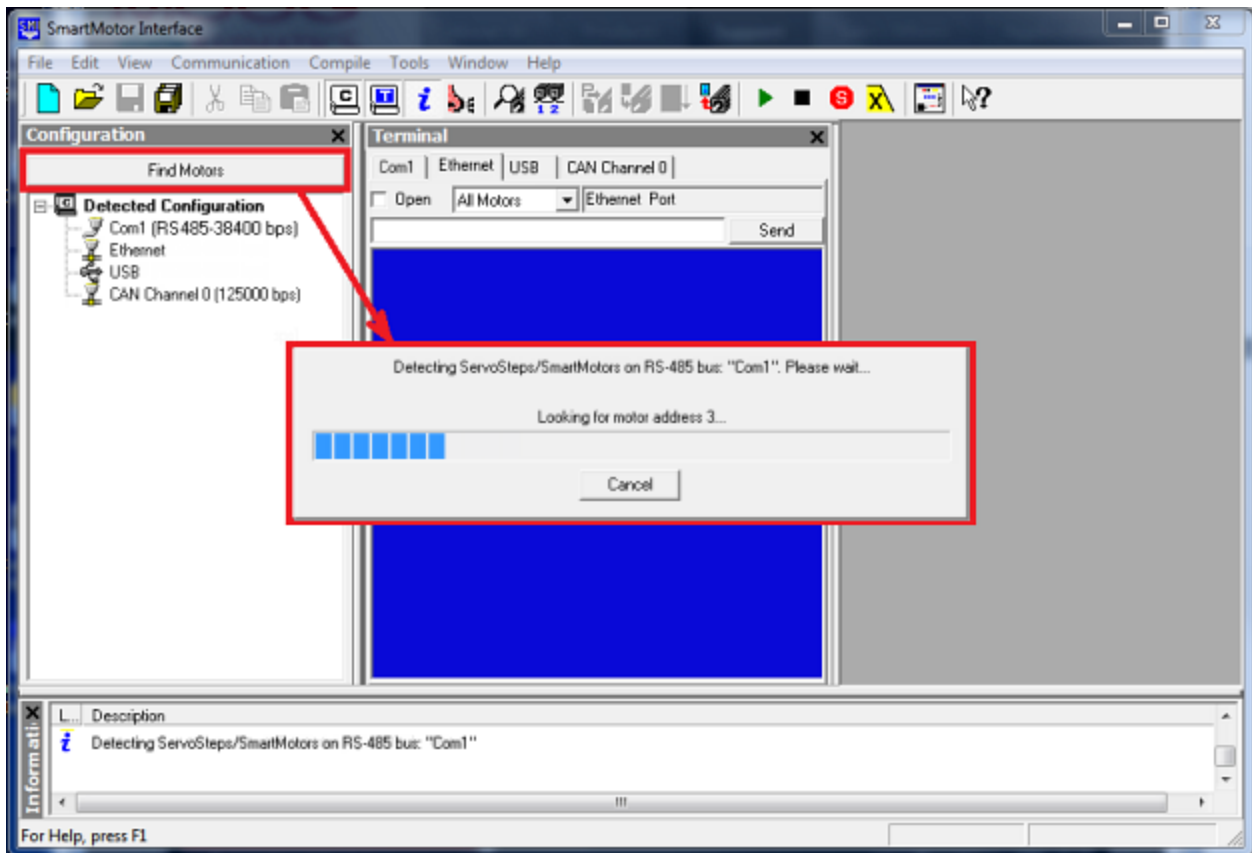

*Find Motors Detecting SmartMotors on the RS-485 Chain*

After the process has completed, the SMI software shows the found motors in the Configuration window under the corresponding communications port. Each motor is represented by a motor icon; the motor's address and firmware version are shown next to the motor icon.

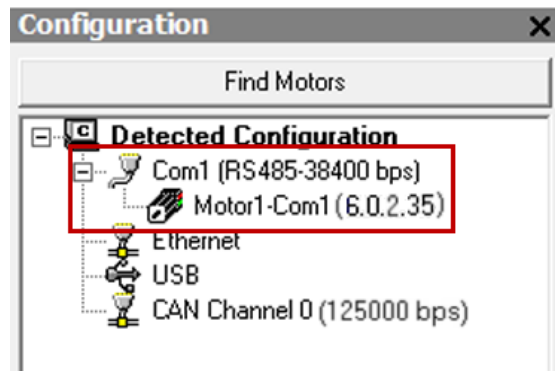

*Configuration Window Showing Found/Detected RS-485 SmartMotor*

To address the motor, right-click on the motor and select Set Motor Address. For more details, see the *SMI Software Help*, which can be accessed within SMI by pressing F1 or from the Help menu.

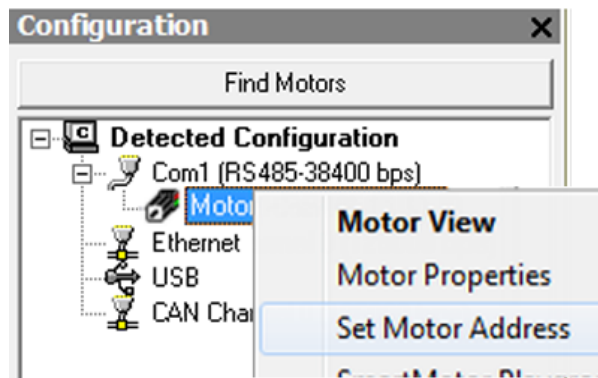

Motor Menu - Set Motor Address

The motor's detailed information can be viewed in the Motor View window, which is accessed by selecting the **Tools > Motor View > Info** tab.

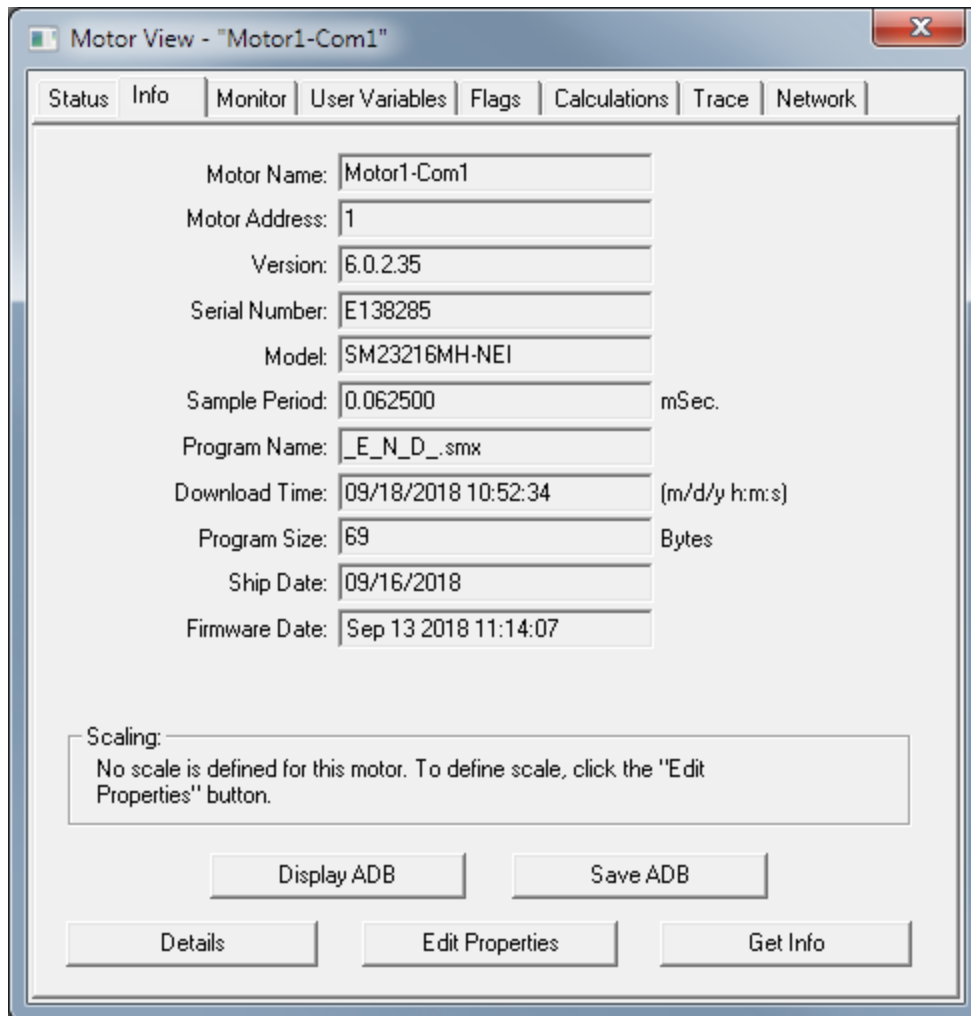

RS-485 Motor View Information

## Using the Detect Motors Feature

**NOTE:** For non-EIP motors, Class 6 currently supports SMI Find/Detect operations on RS-485 and USB connections only. EIP motors additionally support the SMI software Find/Detect operations over Ethernet – the SmartMotor must be previously configured (through COM or USB) with a valid IP address.

This method is similar to the Find Motors method, but it searches only the specified communications port for connected SmartMotors. This is also the recommended method for detecting Class 6 M-style motors after they have been pre-addressed and daisy-chained to the communications port.

**NOTE:** The next figures show examples for a USB SmartMotor. To see similar example figures for RS-485 motors, refer to Using the Find Motors Button on page 40.

To use the Detect Motors feature, in the Configuration window of the SMI software, right-click the desired communications port and select Detect Motors from the menu.

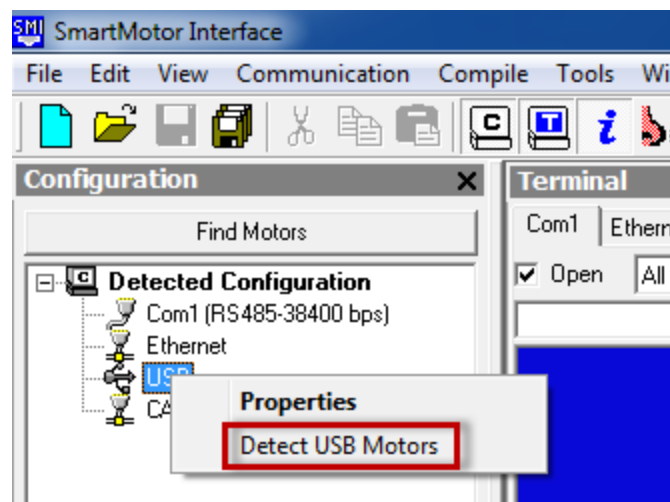

*Selecting the Detect Motors Feature*

The SMI software begins searching for all SmartMotors connected to the specified communications port. A progress bar is shown while the SMI software searches for the motors.

After the process has completed, the SMI software shows the found motors in the Configuration window under the corresponding communications port. Each motor is represented by a motor icon; the motor's address and firmware version are shown next to the motor icon.

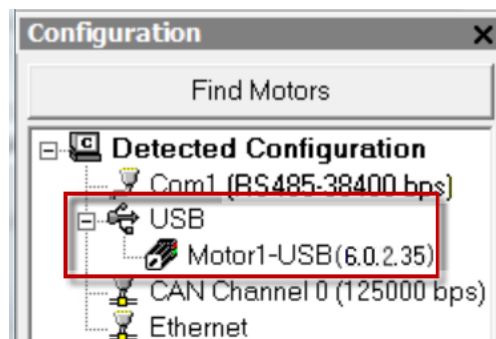

*Configuration Window Showing Found/Detected SmartMotor*

To address the motor, right-click on the motor and select Set Motor Address. For more details, see the *SMI Software Help*, which can be accessed within SMI by pressing F1 or from the Help menu.

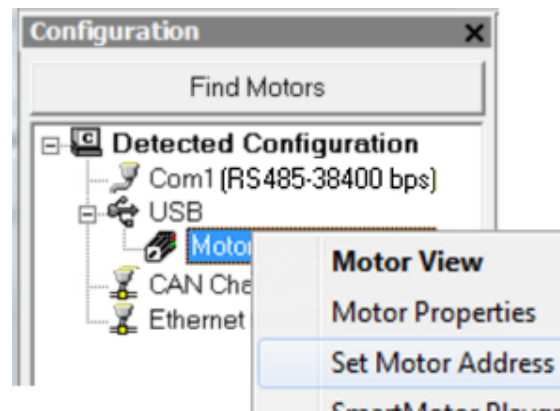

*Motor Menu - Set Motor Address*

The motor's detailed information can be viewed in the Motor View window, which is accessed by selecting the **Tools > Motor View > Info** tab.

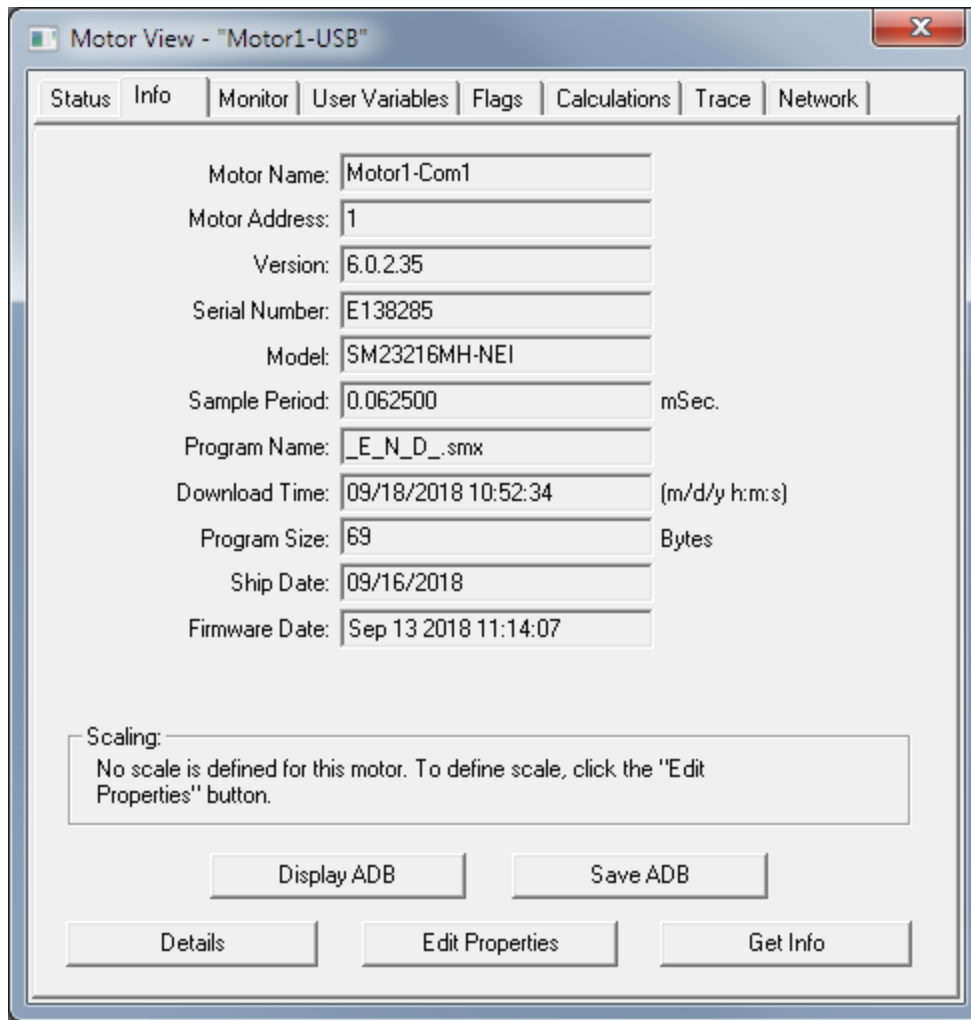

*Motor View Information*

## Checking and Clearing the Status Bits

**NOTE:** In addition to the software information in this section, there is context-sensitive help available within the SMI software interface, which is accessed by pressing the F1 key or selecting Help from the SMI software main menu.

The Motor View window is used to view and monitor various motor parameters. It is used in conjunction with the Terminal window to clear any active overtravel limits.

This procedure assumes that:

- The SmartMotor is connected to the computer. For details, see Connecting the System on page 30.
- The SmartMotor is connected to a power source. For details, see Understanding the Power Requirements on page 28 and Connecting the System on page 30.
- The SMI software has been installed and is running on the computer. For details, see Installing the SMI Software on page 23.
- The SmartMotor has been detected and addressed. For details, see Detecting and Communicating with the SmartMotors on page 40.

## Polling the Motor

To view the current state of the status bits, you must poll the motor.

1. Double-click the motor icon to open the Motor View window (see the next figure).
2. Click the Poll button to begin polling data from the motor.

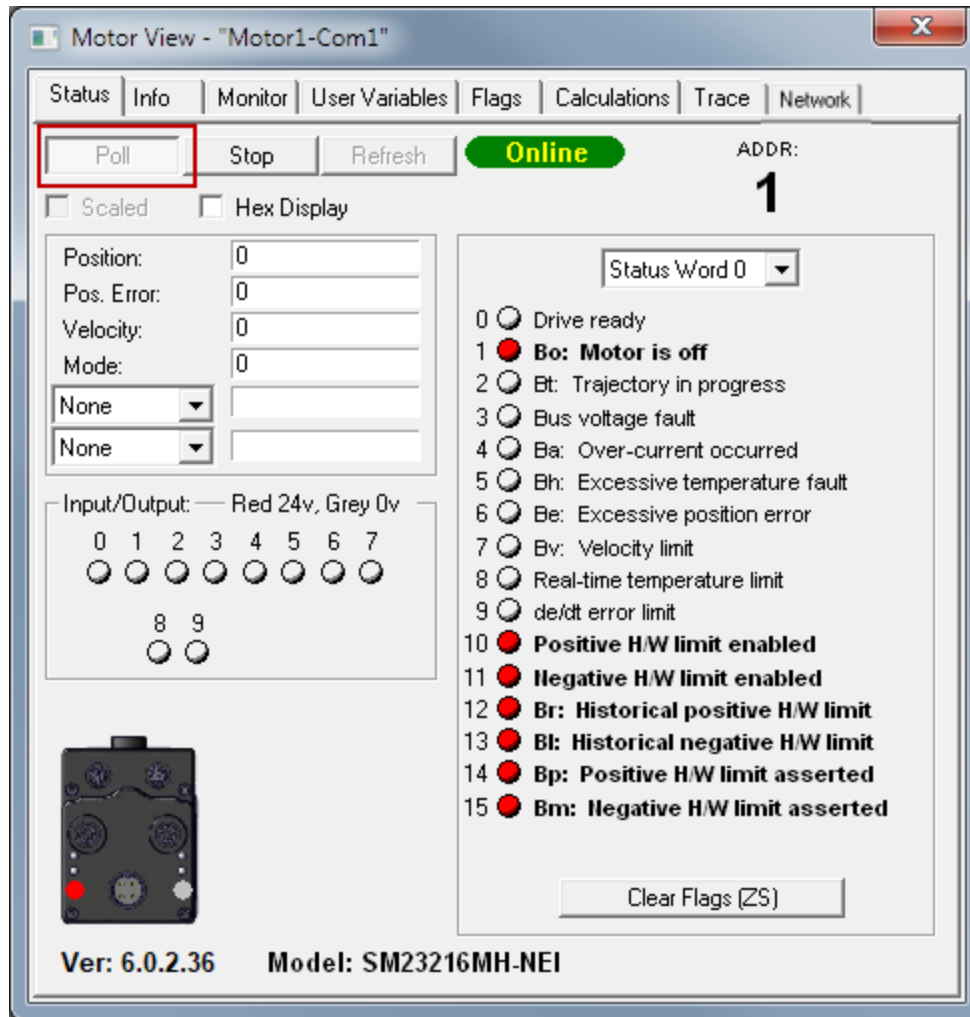

*Motor View with Active Overtravel Limits*

A SmartMotor with no program and no I/O connections will boot up with active overtravel limits (see the red status bits numbered 10 through 15 in the previous figure).

The EIGN() command is used to clear these status bits as described in the next section. EIGN stands for: Enable Inputs as General Use. In the case of EIGN(W,0), the W means a "word" or 16 bits of I/O; the 0 means first word or local I/O. There are only seven local I/O on the D-style motors. Therefore, EIGN(W,0) sets all seven I/O to general-use inputs.

## Clearing the Overtravel Limits and Fault Bits

To disable (clear) the overtravel limits, enter EIGN(2) and EIGN(3) in the SMI software Terminal window. This sets I/O 2 (positive overtravel limit) and I/O 3 (negative overtravel limit) as general inputs/outputs instead of being used as travel limits. To set all status bits in Word 0 as general inputs/outputs, enter EIGN(W,0).

**NOTE:** You can either type the command in the white text box or type the command directly in the blue area of the terminal screen and then click Send or press Enter.

The active and asserted bits are cleared, as shown in the next figures.

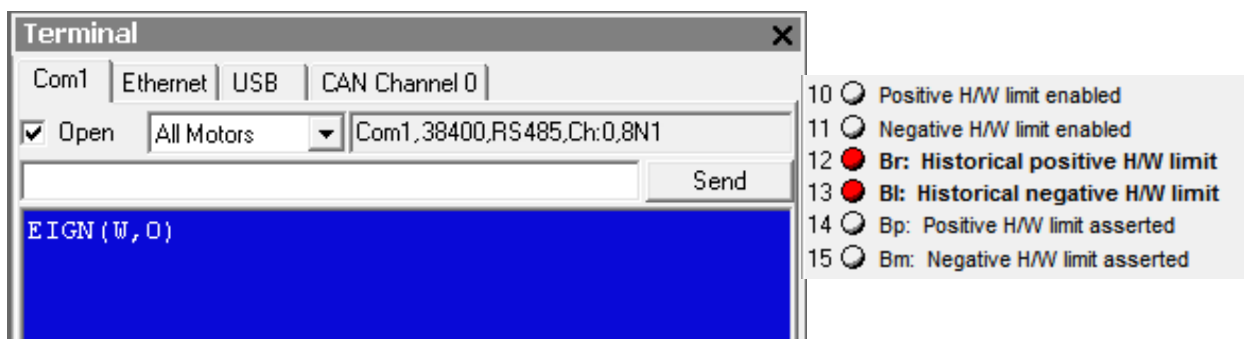

*EIGN Command Entered*

*Active and Asserted Bits Cleared*

To clear the historical fault bits, enter ZS. All remaining fault bits are cleared, as shown in the next figures.

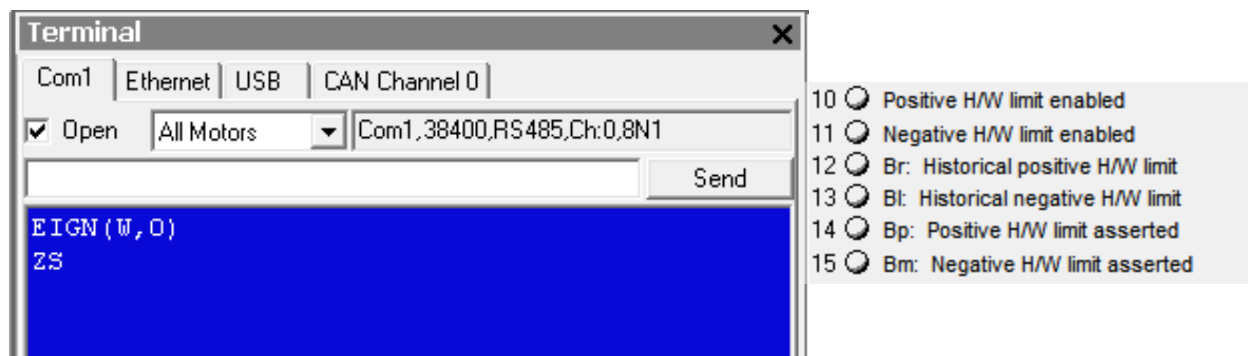

*ZS Command Entered*

*Remaining Bits Cleared*

## Moving the SmartMotor

**NOTE:** In addition to the software information in this section, there is context-sensitive help available within the SMI software interface, which is accessed by pressing the F1 key or selecting Help from the SMI software main menu.

The SMI software contains a Torque mode that is used to test the motor response and ensure the drive is operating properly.

This procedure assumes that:

- The SmartMotor is connected to the computer. For details, see Connecting the System on page 30.
- The SmartMotor is connected to a power source. For details, see Understanding the Power Requirements on page 28 and Connecting the System on page 30.
- The SMI software has been installed and is running on the computer. For details, see Installing the SMI Software on page 23.
- The SmartMotor has been detected and addressed. For details, see Detecting and Communicating with the SmartMotors on page 40.
- The Drive Enable input must be connected and activated with 24V. For the input location, see Motor Connectors and Pinouts on page 31.
- The overtravel limits and fault bits have been cleared. For details, see Checking and Clearing the Status Bits on page 45.

## Making the Motor Move



**WARNING:** The larger SmartMotors can shake, move quickly and exert great force. Therefore, proper motor restraints must be used, and safety precautions must be considered in the workcell design (see Other Safety Considerations on page 8).

To make the SmartMotor move:

1. In the Terminal window, select the tab that matches the communications channel to which your motors are connected. To do this, look at the Configuration window, find the channel where the motors are listed and click that tab name in the Terminal window.

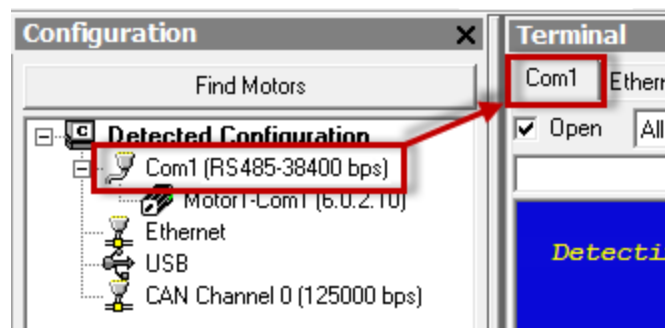

*Tab Selected that Matches the Communications Channel*

**NOTE:** If you do not have the correct tab selected, the commands you enter will not go to the motors and there will be no response.

2. Enter these commands in the Terminal window:

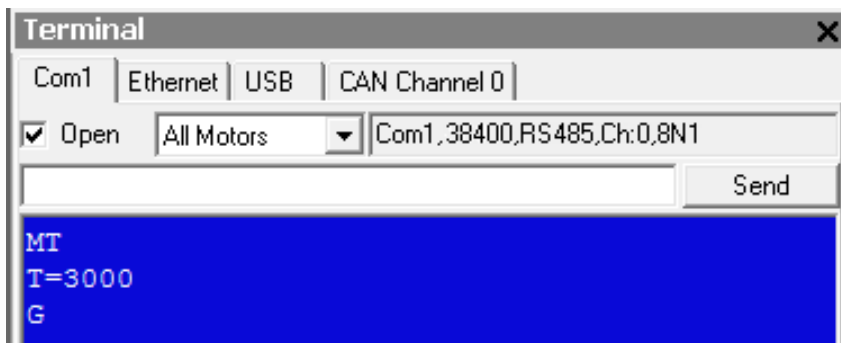

You should immediately see the motor shaft moving in the positive direction (clockwise, when looking at the end of the motor shaft). If the motor does not respond to the commands, see Troubleshooting on page 62 for troubleshooting tips.

**NOTE:** Macros (shortcut keys) can be used to simplify entry of frequently-used commands. For details, see Macros in the *SmartMotor™ Developer's Guide*.

3. After you have observed the motor shaft turning, enter the X command to decelerate the motor to a stop.

## Setting and Reporting Torque

The commands in this section are related to the previous motion procedure. For more details on these commands, see the *SmartMotor™ Developer's Guide*.

### MT (Mode Torque)

MT sets the mode of operation to torque mode. In this mode, the SmartMotor shaft applies a torque independent of position. For more details, see Torque Mode in the *SmartMotor™ Developer's Guide*.

### T=formula (Set Target Torque)

T can be set to any value from -32767 to +32767, which represents -99.99% to +99.99% PWM (pulse-width modulation) commanded.

### RTRQ (Report Actual Torque)

Enter RTRQ at the Terminal window to report the commanded torque from the trajectory generator.

Note that RTRQ typically reports a value that's one less than the T value. In the previous example, T=3000, but RTRQ reports 2999. The value returned by TRQ (and RTRQ) will typically be one less than the T (torque) value due to internal calculations. It may also be reduced in cases where the motor's output is in limitation. TRQ represents the output effort of the motor in both MT (torque mode) and servo modes (MV, MP, etc.). Therefore, it provides a seamless transfer across those modes without causing a ripple or bump in force to the load.

### TS (Set Torque Slope)

The TS command defines how fast the processor applies a change in torque. For an example of the TS command, see the Chart View Example in the *SmartMotor™ Developer's Guide*.

Torque slope can range from -1 to 2147483647 (default). At a value of 65536, the processor changes torque by a value of 1 for each PID sample. The default sample rate is 16000; you can view the current sample rate with the RSAMP command.

**NOTE:** If you're moving from a Class 5 to a Class 6 SmartMotor, the faster Class 6 sample rate means the torque slope operates twice as fast in real-world time.

## Checking the Motor Position

There are several ways to check the motor position:

- Report the position using commands from the Terminal window
- View the position in the Motor View tool

These two methods are described in the next sections. You can also view the position in the Monitor or Chart View software tools. For details, see SMI Software Features in the *SmartMotor™ Developer's Guide*.

This procedure assumes that:

- The SmartMotor is connected to the computer. For details, see Connecting the System on page 30.
- The SmartMotor is connected to a power source. For details, see Understanding the Power Requirements on page 28 and Connecting the System on page 30.
- The SMI software has been installed and is running on the computer. For details, see Installing the SMI Software on page 23.
- The SmartMotor has been detected and addressed. For details, see Detecting and Communicating with the SmartMotors on page 40.
- The overtravel limits and fault bits have been cleared. For details, see Checking and Clearing the Status Bits on page 45.

### Viewing the Motor Position with a Report Command

To report the motor position, in the Terminal window, issue the RPA (Report Position Actual) command:

```
RPA
```

The terminal responds with the current position of the motor:

```
RPA      3593657
```

**NOTE:** The position is reported on the same line as the command; there is no line feed or carriage return for "report" commands.

The RPA command reports the actual motor position at the time the command was issued. Therefore, it is just a "snapshot"—if the motor is moving, the reported position is not dynamically updated.

### Viewing the Motor Position with the Motor View Tool

The Motor View tool provides another way to view the motor position. The advantage of using this tool is that the position is dynamically updated when the motor is moving.

To open the Motor View tool, from the SMI software Configuration window, right-click the motor you want to view and select Motor View from the menu.

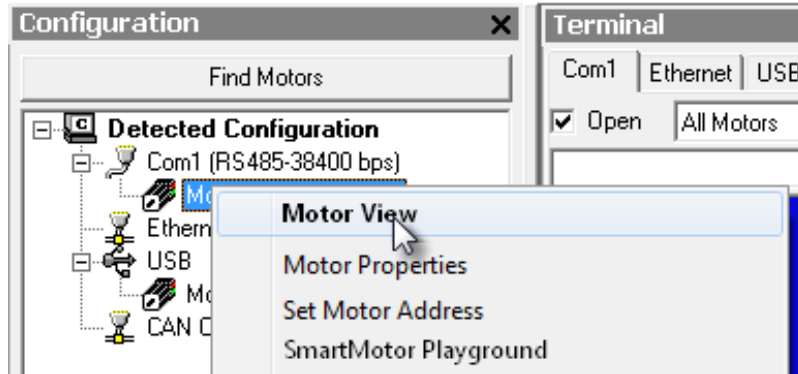

Opening the Motor View Tool

After the Motor View window opens, click the Poll button to begin polling (getting information from) the motor. After polling begins, the motor position is shown in the Position box.

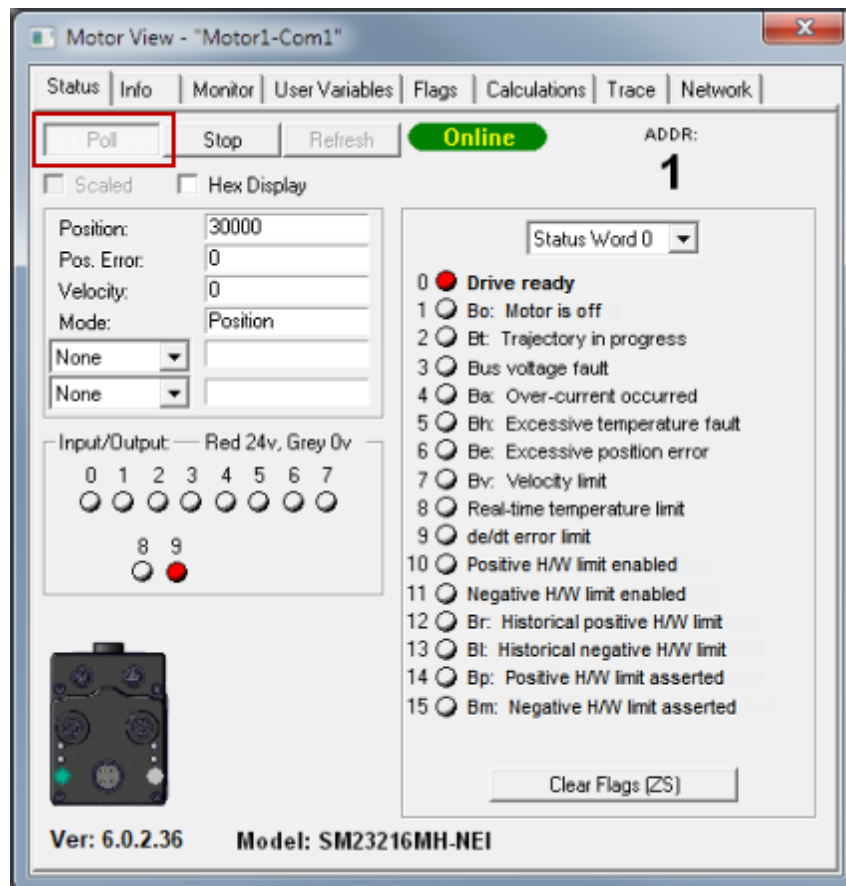

Motor View Tool Showing the Motor Position

## Connectors, Pinouts and Examples

This chapter provides information on the Class 6 SmartMotor connector pinouts and specifications. It also provides example I/O connection diagrams. For information on connecting the motors, see Connecting the System on page 30.

<b>Class 6 M-Style Connector Pinouts</b> .....	<b>53</b>
<b>Class 6 I/O Connection Examples</b> .....	<b>54</b>

## Class 6 M-Style Connector Pinouts

The table below shows the pinouts for the connectors on the Class 6 M-style SmartMotors.

**NOTE:** In the table, I/O pins 5 and 6 OUTPUTS apply to MT2 motors only.

PIN	Main Power	Specifications:	Notes:	P1
1	Control Power In	+24 V (±20%), 32 V Max	Also Supplies I/O	<p>M16 4-Pin Male</p>
2	Chassis Ground	Chassis Ground Only	Not Connected to Common	
3	Control, Com, I/O and Amplifier Ground	Common Ground (Req'd. Ground)	Nonisolated	
4	Amplifier Power In	+24 V Min, 48 V Max	Powers Amplifier Only	
PIN	Communications Connector	Specifications:	Notes:	P2
1	Control, Com, I/O and Amp Ground	Common Ground	Nonisolated	<p>M12 8-Pin Female End View</p>
2	RS-485 B, Com ch. 0	115.2 Kbaud Max		
3	RS-485 A, Com ch. 0			
4	Encoder A+ Input/Output			
5	Encoder B- Input/Output	125 KHz Individual Line Frequency	Configurable as Encoder Output	
6	Encoder A- Input/Output			
7	+5V Out	50 mA Max		
8	Encoder B+ Input/Output	125 KHz Individual Line Frequency	Configurable as Encoder Output	
PIN	24V I/O Connector	Specifications:	Notes:	P3
1	IN0 GP, also Analog Input	Inp Impedance > 10 kohm	For Inputs: 7 Configurable Inputs Low Lvl Thld: 3.6 V Max High Lvl Thld: 5.0 V Min Inp Hysteresis: 1.0 V Min Analog Input Scale: 10 V FS	<p>M12 12-Pin Female End View</p>
2	IN1 GP, also Analog Input			
3	IN2 Pos Limit or GP			
4	IN3 Neg Limit or GP			
5	IN/OUT4*GP or Ext. Enc. Index Capture			
6	IN/OUT5*GP or Int. Enc. Index Capture			
7	IN6 GP, G Cmd, or Homing Input			
8	IN7 Drive Enable	250 mAmps Max	For Outputs: Do not exceed 500 mAmps combined	
9	OUT8 Brake or GP			
10	OUT9 Not Fault or GP			
11	+24 VDC Out (supplied from P1, Pin 1)	12.5 V Min, 23 V Max Load 2 Amps Max.		
12	Ground Common	Common Ground	Nonisolated	

\*Output available only on MT2 motors.

PIN	Industrial Ethernet Connectors	Specifications:	Notes:	P4
	EtherNet/IP, EtherCAT PROFINET	10/100BASE-T	Shield tied to motor housing	<p>M12 4-Pin</p>
1	+TX +TD	EtherCAT=100BASE-TX	EtherCAT=Input (L), Output (R)	
2	+RX +RD			
3	-TX -TD			
4	-RX -RD			

**NOTE:** All specifications are subject to change without notice. Consult the factory for the latest information.

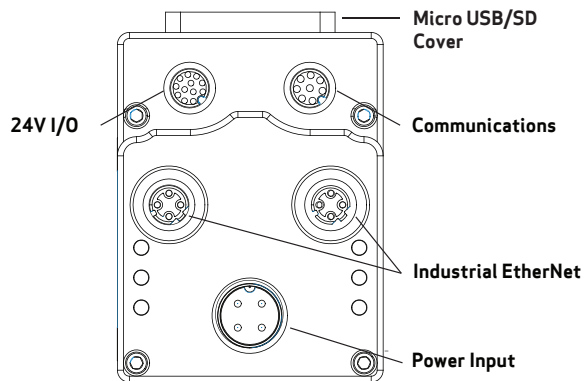

**CAUTION:** Exceeding 32 VDC into control power on any of the +24 V pins may cause immediate damage to the internal electronics. Exceeding a sustained voltage of 48 V to pin 4 of the P1 Power Input may cause immediate damage to the internal electronics. Exceeding these voltage limits will void the warranty.

**CAUTION:** M-style connectors must be finger tightened only! DO NOT use a tool. Doing so can cause overtightening of the connection, which may damage the connector and will void the warranty.

**CAUTION:** For -IP option (IP sealed) motors, whenever the micro USB/SD cover is removed, the seal must be inspected and the cover must be reinstalled without damaging the seal in order to maintain the integrity of the sealed motor.

## Class 6 I/O Connection Examples

These figures show I/O connection examples for the Class 6 motors. See the Notes at the end of this section. Also, refer to Class 6 M-Style Connector Pinouts on page 53 for connector specifications. As noted previously, connector and LED positions are the same for MT2 motors.

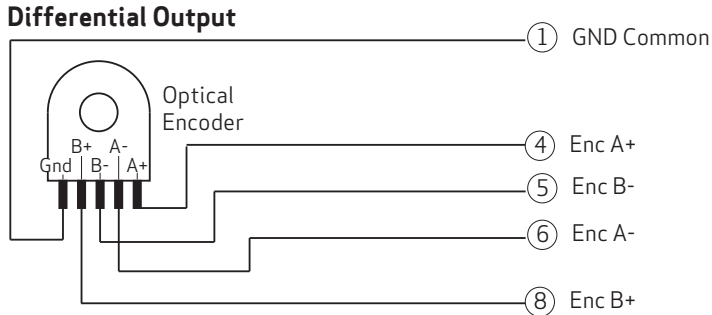

### COMMUNICATION

PIN	FUNCTION
1	GND-COMMON
2	RS-485B CHO
3	RS-485A CHO
4	ENC A+ IN
5	ENC B- IN
6	ENC A- IN
7	5 VDC OUT
8	ENC B+ IN

**NOTE:** In the next figures, I/O pins 5 and 6 OUTPUTS apply to MT2 motors only.

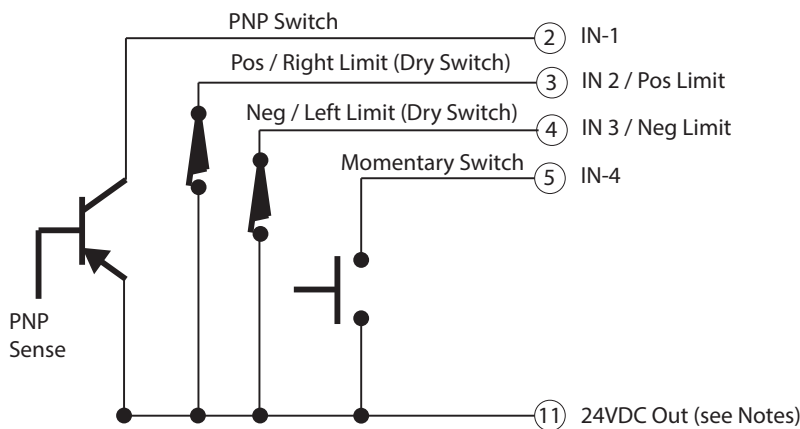
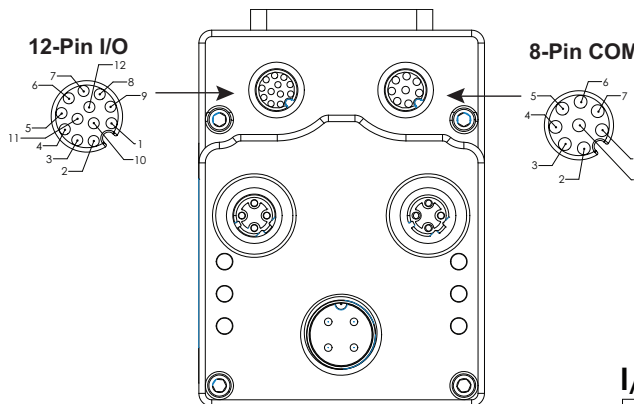

### I/Os

PIN	FUNCTION
1	IN0
2	IN1
3	IN2/POSLIMIT
4	IN3/NEGLIMIT
5	IN/OUT4
6	IN/OUT5
7	IN6
8	IN7-DRVEN
9	OUT8/BRAKE
10	OUT9-NOFAULT
11	24 VDC OUT**
12	GND

\*\*2 amps max.

Class 6 M-Style Analog Pot and Sensor

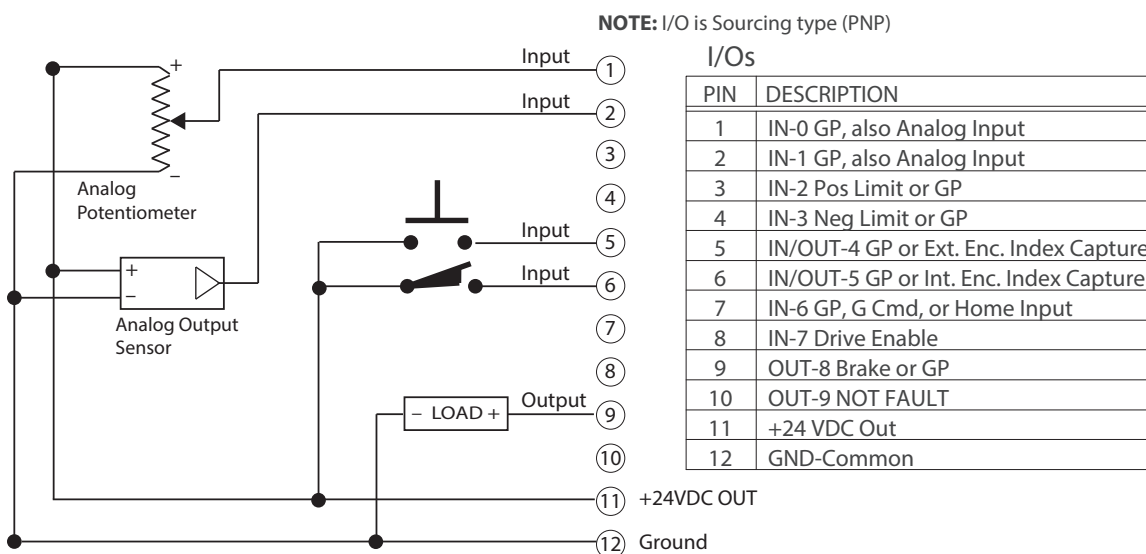

**NOTE:** Be sure that voltage drop across the potentiometer is appropriate for the rated wattage of the potentiometer, i.e.,  $Watts = Voltage^2 / Ohms$ . For example, at 24 VDC and using a 10 kohm pot:  $V^2/R = 0.06 Watts$ .

**NOTES:**

**I/O TYPE**

The Class 6 motor I/O is Sourcing type (PNP).

**DRIVE ENABLE**

The Drive Enable input (pin 8) must be satisfied in order for the motor to turn.

**24 VOLTS DC POWER**

Do not use the motor as a power source for 24 VDC loads at pin 11 of the I/O connector.

- If you supply control power on the main connector, the I/O connector should not be a feed through for loads, and the I/O devices should be sourced from an external power supply.
- Loads on specific outputs are allowed (when within the described limits).

## DIFFERENTIAL ENCODER

The Differential Encoder inputs use the standard RS-485 chipset:

- If a true differential output TTL encoder is used, just wire A and B signals as labeled.



**CAUTION:** NO differential encoder signals higher than 5V TTL should be used!

## RS-485

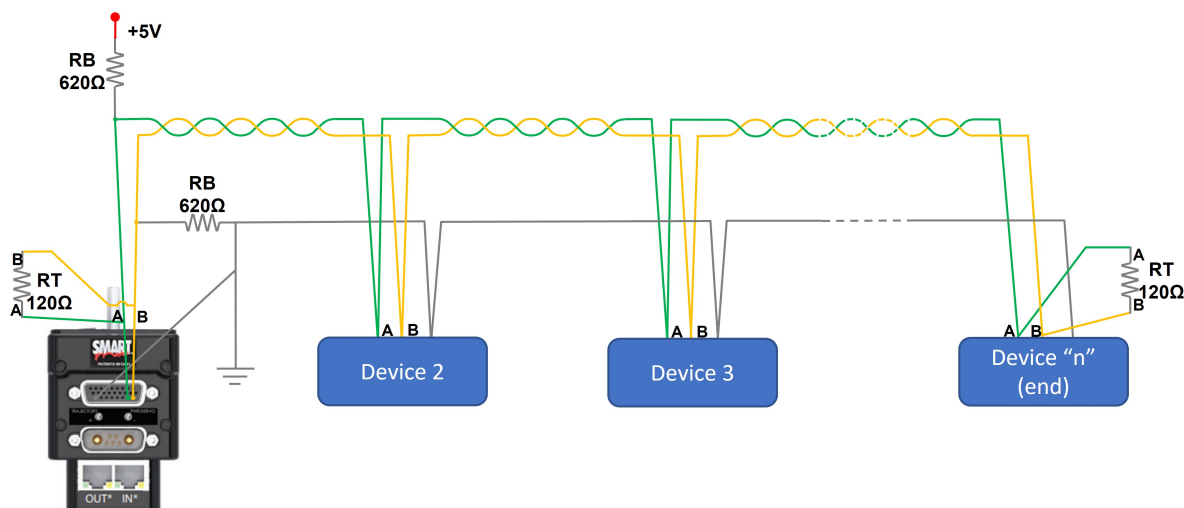

**Note:** The 620 ohm biasing resistors are not needed in most cases but recommended if there are communication problems.

## +5 VDC PIN

The +5 VDC pin can only source 50 mA and is meant for RS-485 biasing only. If it is used to power an external 5V TTL encoder, the device must not draw more than 50 mA max.

## ENCODER OUTPUT

For Class 6 M-style motors, the internal encoder is conditioned with error correction and resolution adjustments when used normally for positioning (i.e., as seen in the RPA command “actual position”). However, when directed as an output and received into another motor for the purposes of follow mode, there are several things to be aware of at the receiving motor:

- The resolution seen at the receiving motor will be 4096 instead of 4000. MFMUL and MFDIV will need to compensate accordingly.
- The direction will be negative (assuming a straight-through connection of the 8-pin “Y” cable).
- There are non-accumulating, single-turn errors that are not compensated.

## Other Class 6 M-Style Changes

This chapter provides information on getting started with your SmartMotor.

<b>EOBK(IO) Command Limitations</b> .....	<b>58</b>
<b>Ethernet Error, Status Word 2 Bit 6</b> .....	<b>58</b>
<b>I/O Control Details</b> .....	<b>58</b>
I/O Control Examples .....	59
<b>Scale Factor Calculation - Sample Rates</b> .....	<b>59</b>
<b>Commands for Class 6</b> .....	<b>60</b>
<b>Commands That Have Changed</b> .....	<b>60</b>
<b>Commands Not Supported</b> .....	<b>61</b>
<b>Commands Supporting the DS2020 Combitronic System</b> .....	<b>61</b>
<b>Features not Available in Class 6 M-Style</b> .....	<b>61</b>

## EOBK(IO) Command Limitations

The EOBK(IO) command configures the specified SmartMotor output to control an external brake. However, only output 8 works for the Class 6 M-style SmartMotor. Therefore, the valid EOBK(IO) values are:

- EOBK(8) to enable
- EOBK(-1) to disable

## Ethernet Error, Status Word 2 Bit 6

The intent of Status Word 2 bit 6 is to inform the user that one or more errors has occurred through the Ethernet interface. To determine the specific error that has occurred, consult the RETH command description in the corresponding fieldbus guide.

## I/O Control Details

The SmartMotor fieldbus guides describe the details of accessing I/O for each communication protocol. The *SmartMotor™ Developer's Guide* describes I/O control details for RS-485 communications.

In a local program or serial command, the OR, OS and OUT commands are the same as Class 5. For details, see the *SmartMotor™ Developer's Guide*.

For the Class 6 M-style SmartMotor, it is important to note which are inputs, which are outputs, and which have special functions. For those details, refer to the next table.

Logical I/O Number	Input or Output	Possible (Selectable) Functions	Default Operation
0	Input only	General purpose, discrete or analog	General purpose
1	Input only	General purpose, discrete or analog	General purpose
2	Input only	Positive limit, or general purpose	Positive limit
3	Input only	Negative limit, or general purpose	Negative limit
4	Input/Output*	General purpose, or index capture for external encoder	General purpose
5	Input/Output*	General purpose, or index capture for internal encoder	General purpose
6	Input only	General purpose, G command, or homing input	General purpose
7	Input only	Drive enable	Drive enable
8	Output only	Brake or general-purpose output	Brake output
9	Output only	Not fault or general purpose output	Not fault output

\*This Output is only available on the Class 6 MT2 SmartMotor.

## I/O Control Examples

To make output 8 a general-purpose output:

```
EOBK(-1)    'Disables brake output from any I/O pin
OR(8)       'Clears output (0 V)
OS(8)       'Sets output (24 V)
EOBK(8)     'Restores output 8 to brake function
```

To read inputs:

```
x=IN(W,0,15) 'Reads inputs 0,1,2,3 as bitfield stored into variable x
EIGN(2)      'Disables positive limit, makes a general-purpose input
EIGN(3)      'Disables negative limit, makes a general-purpose input
EILP         'Re-enables positive limit
RIN(3)       'Reads input 3
```

## Scale Factor Calculation - Sample Rates

The sample rate for Class 6 SmartMotors is fixed at 16,000 Hz (16 kHz).

## Commands for Class 6

The commands in this section were added for the Class 6 SmartMotor.

**NOTE:** These commands are *not* available for the Class 5 SmartMotor.

**EOFT:** Configure a specified output for the fault indication.

**GROUP(function,value):** Configure group addressing settings of the Combitronic over Ethernet (UDP) communications.

**IDENT=, RIDENT, x=IDENT:** Set the IDENT value which is useful for user programs to detect which axis they are. Report, use in expression, or assign the value of IDENT to a user variable.

**IPCTL(action,"string"):** Sets IP address, Mask, or Gateway:  
action= 0, set IP address; 1, set Mask; 2, set Gateway;  
"string": formatted as an IP address and entered as a string;  
e.g., IPCTL(0,"192.168.0.10") sets IP address to 192.168.0.10

**PRINT0:** Explicitly outputs to the COM 0 serial port.

**PRINT8:** Explicitly outputs to the USB port.

**RGROUP(function):** Report group addressing setting of the Combitronic over Ethernet (UDP) communications.

**RSP5:** Reports network interface card firmware version.

**RUSB(arg), x=USB(arg):** Report the value of the specified USB status word (specified by arg) or assign it to a variable.

**RUSB, x=USB:** Report the value of USB status word 0 or assign it to a variable.

**SNAME("string"):** Sets a unique PROFINET station name. See the *Class 6 SmartMotor™ PROFINET Guide*.

For details on these commands, see the *SmartMotor™ Developer's Guide*.

These Industrial Ethernet (IE) commands were added for the Class 6 SmartMotor:

**NOTE:** These commands are *not* available for the Class 5 SmartMotor.

**RETH(arg), x=ETH(arg):** Assign result to a variable or report errors and certain status information for the EtherCAT or PROFINET bus. See the corresponding fieldbus manual for arg values.

**ETHCTL(action,value):** Controls network features. See the corresponding fieldbus manual for details.

For details on these commands, see the *Class 6 SmartMotor EtherCAT Guide* or the *Class 6 SmartMotor™ PROFINET Guide*.

## Commands That Have Changed

These commands have been modified for the Class 6 M-style SmartMotor:

**PRINT:** Corresponds with the value of STDOUT, which is 8 (USB port) by default. Note that this behavior is different than in Class 5 motors.

**STDOUT=8:** (Default) Sets internal report commands to the USB port.

For details on these commands, see the *SmartMotor™ Developer's Guide*.

## Commands Not Supported

These commands are not supported in the Class 6 M-style SmartMotor:

**CAN related:** CADDR=, CANCTL, CBAUD=, RCADDR, RCAN, RCBAUD

**Sync motion commands:** (require Combitronic, see the next note) ADTS, ATS, DTS, GS, PRTS, PRTSS, PTS, PTSS, RPTSD, RPTST, TSWAIT, VTS

**NOTE:** The sync motion commands are available on the -EIP option Class 6 M-style SmartMotor with the netX 52 processor, NXF EIP version 3.4.0.5 or later, and SmartMotor firmware 6.0.2.35 or later, as those motors do support Combitronic technology over Ethernet.

**Commands associated with the second serial port or other hardware that is not available in the Class 6 M-style motors:** BAUD(1)=, CCHN on channel 1, ECHO1, ECHO\_OFF1, OCHN on channel 1, PRINT1, RBAUD(1), RGETCHR1, RLEN1, ROC, ROF, SILENT1, SLEEP1, TALK1, WAKE1,

**Other:** ENCCTL, ENCD, EIDX, MDH, MDHV, MDT, OC, OF, PID, SCALEA, SCALEP, SCALEV

## Commands Supporting the DS2020 Combitronic System

Note that the Class 6 M-style motors do not support the DS2020 Combitronic system. Therefore, any commands specific to that product are not available on these motors.

For details on the commands for the DS2020 Combitronic system, see the topic "Commands for DS2020 Combitronic" in the *SmartMotor™ Developer's Guide*.

## Features not Available in Class 6 M-Style

These features are not implemented:

- CAN bus communications
- Combitronic communications (only available on properly equipped -EIP option motors)
- DeviceNet protocol
- PROFIBUS protocol
- I<sup>2</sup>C communications
- AD1 option

## Troubleshooting

This section provides troubleshooting information for common problems. For additional support resources, see: <http://www.animatics.com/support.html>.

Issue	Cause	Solution
<b>Communication and Control Issues</b>		
Motor control power light does not illuminate.	Control power is off, disconnected or incorrectly wired.	Check that control power is connected to the proper pins and turned on. For connection details, see Connecting the System on page 30.
Motor does not communicate with SMI.	Transmit, receive or ground pins are not connected correctly.	Ensure that transmit, receive and ground are all connected properly to the host PC.
	Motor program is stuck in a continuous loop or is disabling communications.	To prevent the program from running on power up, use the Communications Lockup Wizard located on the SMI software Communications menu.
Motor disconnects from SMI sporadically.	COM port buffer settings are too high.	Adjust the COM port buffer settings to their lowest values. This is done in the Windows Device Manager> Advanced Settings dialog box for the associated COM port driver.
	Poor connection on cable from motor to PC.	Check the cable connections and/or replace it.
	Power supply unit (PSU) brownout.	PSU may be undersized for the application, which causes it to brown-out during motion. Make moves less aggressive, increase PSU size or change to a linear unregulated power supply.
Motor stops communicating after power reset, requires redetection.	Motor does not have its address set in the user program. NOTE: Serial addresses are lost when motor power is off or reset.	Use the SADDR or ADDR= command within the program to set the motor address.
Red PWR SERVO light illuminated.	Red LED indicates the drive stage is OFF. This may be due to never having been turned on yet, or a critical shaft protection fault.	To discover the source of the fault, use the Motor View tool located on the SMI software Tools menu.
Motor doesn't turn.	Faults not cleared and/or drive enable not satisfied.	Clear faults (see Checking and Clearing the Status Bits on page 45). Satisfy the drive enable input (see Drive Enable Input on page 29).
<b>Common Faults</b>		
Bus voltage fault.	Bus voltage is too high for operation.	Check servo bus voltage. Check for excessive regenerative energy from motor due to no/insufficient shunt resistor.
	Bus voltage is too low for operation.	If motor uses the dual-power configuration (separate drive and control power supplies), ensure that both power supplies are connected and are sized correctly for the motor.
Overcurrent occurred.	Motor intermittently drew more than its rated level of current. Does not cease motion.	Consider making motion less abrupt with softer tuning parameters or lower acceleration profiles.
Excessive temperature fault.	Motor has exceeded internal PCB temperature limit of 85°C. Motor will remain unresponsive until it cools down below 80°C.	Motor may be undersized or ambient temperature is too high. Check motor sizing for the application in terms of continuous rating. Consider adding heat sinks or forced air cooling to the system.
Excessive position error.	The motor's commanded position and actual position differ by more than the user-supplied error limit.	Increase error limit, decrease load or make movement less aggressive. Also, ensure you are not voltage limited for the torque at speed required. If running from less than 48 VDC, check ratings for lower bus voltages and ensure the motor is within required torque capacity.

### For Further Information...

Issue	Cause	Solution
Motor faults on position error only after a certain amount of time.	Motor sized incorrectly.	Check motor sizing for the application in terms of continuous rating. Also, ensure you are not voltage limited for the torque at speed required. If running from less than 48 VDC, check ratings for lower bus voltages and ensure the motor is within required torque capacity.
Motor is not accurately corresponding to trajectory.		
Historical positive/negative hardware limit faults.	A limit switch was tripped in the past.	Clear errors with the ZS command.
	Motor does not have limit switches attached.	Configure the motor to be used without limit switches by setting their inputs as general use.
<b>Programming and SMI Issues</b>		
Several commands not recognized during compiling.	Compiler default firmware version set incorrectly.	Use the Compiler default firmware version option in the SMI software Compile menu to select a default firmware version closest to the motor's firmware version. In the SMI software, view the motor's firmware version by right-clicking the motor and selecting Motor Properties.

## For Further Information...

Now that your SmartMotor is installed and operating, the next step is to learn about its features, commands and programming in order to create a useful application.

Information on SMI software features, SmartMotor programming, communications, motion control and more is provided in the *SmartMotor™ Developer's Guide*. That guide also includes a complete SmartMotor command reference, and an Appendix of other related topics that are useful during application development.

# TAKE A CLOSER LOOK

Moog Animatics, a sub-brand of Moog Inc. since 2011, is a global leader in integrated automation solutions. With over 30 years of experience in the motion control industry, the company has U.S. operations and international offices as well as a network of Automation Solution Providers worldwide.

Moog Animatics  
1995 NC Hwy 141  
Murphy, NC 28906  
United States

Email: [animatics\\_sales@moog.com](mailto:animatics_sales@moog.com)

For Animatics product information, visit [www.animatics.com](http://www.animatics.com)

For more information or to find the office nearest you, email [animatics\\_sales@moog.com](mailto:animatics_sales@moog.com)

Moog is a registered trademark of Moog Inc. and its subsidiaries.  
All trademarks as indicated herein are the property of Moog Inc. and its subsidiaries.  
©2015-2026 Moog Inc. All rights reserved. All changes are reserved.

Moog Animatics Class 6 M-Style SmartMotor™ Installation and Startup Guide,  
Rev. L, February 2026, SC80100006-001

[www.animatics.com](http://www.animatics.com)

