

INSTALLATION AND STARTUP FOR

# FULLY INTEGRATED SERVO MOTORS

CLASS 6 SMARTMOTOR™ WITH  
COMBITRONIC™ TECHNOLOGY

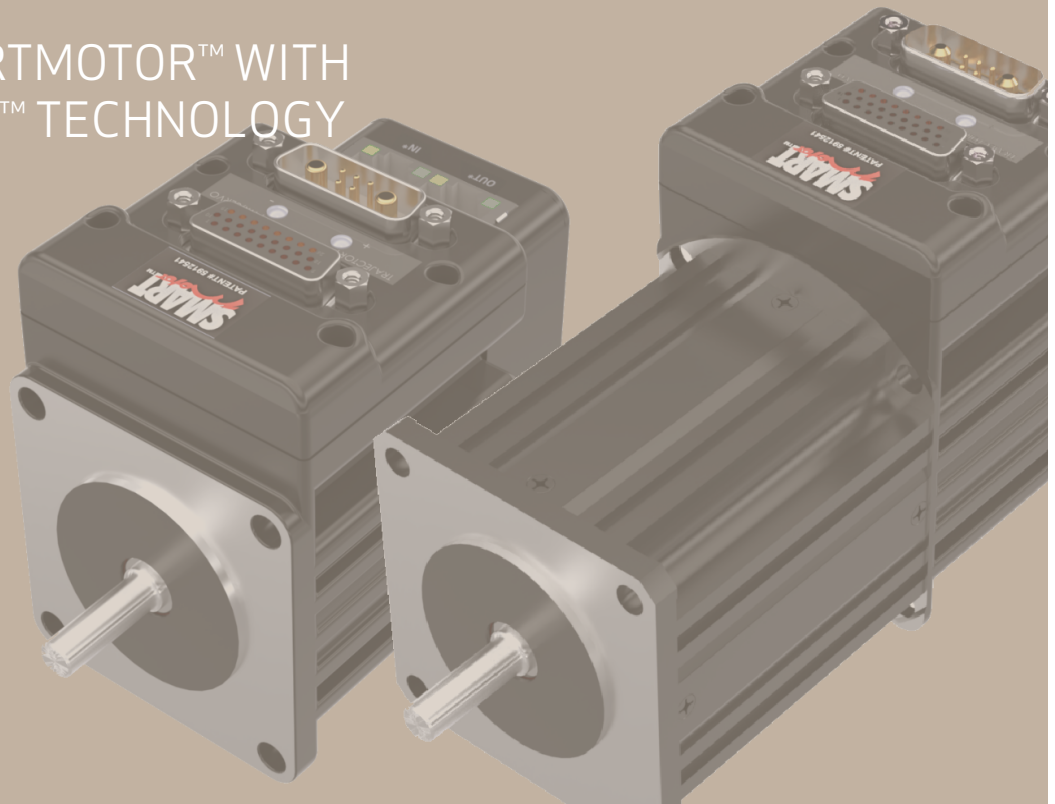

Rev. G, February 2026

DESCRIBES THE INSTALLATION AND  
STARTUP OF THE CLASS 6 D-STYLE  
SMARTMOTOR™

[www.animatics.com](http://www.animatics.com)

**MOOG**  
ANIMATICS

# Copyright Notice

©2015-2026 Moog Inc.

Moog Animatics Class 6 D-Style SmartMotor™ Installation and Startup Guide, Rev. G, SC80100022-001.

This manual, as well as the software described in it, is furnished under license and may be used or copied only in accordance with the terms of such license. The content of this manual is furnished for informational use only, is subject to change without notice and should not be construed as a commitment by Moog Inc., Animatics. Moog Inc., Animatics assumes no responsibility or liability for any errors or inaccuracies that may appear herein.

Except as permitted by such license, no part of this publication may be reproduced, stored in a retrieval system or transmitted, in any form or by any means, electronic, mechanical, recording, or otherwise, without the prior written permission of Moog Inc., Animatics.

The programs and code samples in this manual are provided for example purposes only. It is the user's responsibility to decide if a particular code sample or program applies to the application being developed and to adjust the values to fit that application.

Moog Animatics and the Moog Animatics logo, SmartMotor and the SmartMotor logo, Combitronic and the Combitronic logo are all trademarks of Moog Inc., Animatics. Other trademarks are the property of their respective owners.

Please let us know if you find any errors or omissions in this manual so that we can improve it for future readers. Such notifications should contain the words " Class 6 D-Style SmartMotor Installation and Startup Guide" in the subject line and be sent by e-mail to: [animatics\\_sales@moog.com](mailto:animatics_sales@moog.com). Thank you in advance for your contribution.

Contact Us:

Moog Animatics  
1995 NC Hwy 141  
Murphy, NC 28906  
USA

Website: [www.animatics.com](http://www.animatics.com)

Email: [animatics\\_sales@moog.com](mailto:animatics_sales@moog.com)

---

# Table Of Contents

<b>Introduction</b> .....	<b>6</b>
Purpose .....	7
Combitronic Technology .....	7
I/O Device CAN Bus Controller .....	8
Safety Information .....	9
Safety Symbols .....	9
Other Safety Considerations .....	9
Motor Sizing .....	9
Environmental Considerations .....	9
Machine Safety .....	10
Documentation and Training .....	10
Additional Equipment and Considerations .....	11
Safety Information Resources .....	11
Additional Documents .....	11
Related Guides .....	12
Other Documents .....	12
Additional Resources .....	12
<b>SmartMotor Overview</b> .....	<b>14</b>
SmartMotor Introduction .....	15
SmartMotor Features and Options .....	15
Class 6 D-Style Motors .....	16
Standard Features .....	16
Optional Features .....	17
Connectors and LED Locations .....	17
Fieldbus Options .....	18
CANopen Fieldbus Protocol .....	18
EtherCAT Fieldbus Protocol .....	18
PROFINET Fieldbus Protocol .....	19
EtherNet/IP Fieldbus Protocol .....	19
Dual Power Configuration .....	21
SmartMotor Theory of Operation .....	22
<b>Getting Started</b> .....	<b>24</b>
Unpacking and Verifying Your Shipment .....	26
Installing the SMI Software .....	26
Installation Procedure .....	26

---

Installation Verification .....	29
Accessing the SMI Software Interface .....	29
Understanding the Power Requirements .....	31
SmartMotor Power Requirements .....	31
CPU, I/O and Communications Power .....	32
CPU Power Requirements .....	32
I/O Power Requirements .....	33
Communications Power Requirements .....	33
Drive Enable Input .....	33
Connecting the System .....	34
Minimum Requirements .....	34
Connectors and Pinouts .....	35
D-Style Connections At A Glance .....	35
Demo or Development System .....	36
RS-232 Through USB .....	36
Adding a USB to Serial Adapter .....	36
RS-232 with Protective Shunt .....	37
RS-232 Multidrop with Add-A-Motor Cables .....	37
USB to HD26 Connector .....	38
Dual Power Configuration .....	38
CDS Schematic .....	39
CDS on the HD26 Connector .....	39
CDS on the 7W2 Connector (CDS7) .....	40
Industrial Ethernet Network .....	43
Min and Max Cable Length .....	44
Ethernet Cables .....	44
Understanding the Status LEDs .....	45
Detecting and Communicating with the SmartMotors .....	45
Understanding the Detection and Configuration Options .....	46
Using the Find Motors Button .....	46
Using the Detect Motors Feature .....	49
Checking and Clearing the Status Bits .....	51
Polling the Motor .....	52
Clearing the Overtravel Limits and Fault Bits .....	53
Moving the SmartMotor .....	54
Making the Motor Move .....	54
Setting and Reporting Torque .....	55
Checking the Motor Position .....	56
Viewing the Motor Position with a Report Command .....	56
Viewing the Motor Position with the Motor View Tool .....	56

---

<b>Connectors, Pinouts and Examples</b> .....	<b>58</b>
Class 6 D-Style Connector Pinouts .....	59
Class 6 D-Style I/O Connection Examples .....	60
Class 6 D-Style HD26 Cable Connector (PN: CBLHD26-ASM) .....	62
<b>Other Class 6 D-Style Changes</b> .....	<b>63</b>
Batteryless Absolute Multiturn Encoder .....	64
Absolute Encoder Control Commands .....	64
EOBK(IO) Command Limitations .....	64
EOFT(IO) Command Limitations .....	64
Ethernet Error, Status Word 2 Bit 6 .....	64
I/O Control Details .....	65
I/O Control Examples .....	66
Scale Factor Calculation - Sample Rates .....	66
Commands for Class 6 .....	67
Commands That Have Changed .....	68
Commands Not Supported .....	68
Commands Supporting the DS2020 Combitronic System .....	68
Features not Available in Class 6 D-Style .....	68
<b>Troubleshooting</b> .....	<b>69</b>
<b>For Further Information...</b> .....	<b>70</b>

# Introduction

This chapter provides information on the purpose of the manual, safety information, and additional documents and resources.

<b>Purpose</b> .....	<b>7</b>
Combitronic Technology .....	7
I/O Device CAN Bus Controller .....	8
<b>Safety Information</b> .....	<b>9</b>
Safety Symbols .....	9
Other Safety Considerations .....	9
Motor Sizing .....	9
Environmental Considerations .....	9
Machine Safety .....	10
Documentation and Training .....	10
Additional Equipment and Considerations .....	11
Safety Information Resources .....	11
<b>Additional Documents</b> .....	<b>11</b>
Related Guides .....	12
Other Documents .....	12
<b>Additional Resources</b> .....	<b>12</b>

## Purpose

The *Class 6 D-Style SmartMotor™ Installation and Startup Guide* (the document you are currently reading) provides an overview of the Class 6 D-style SmartMotor, along with information on unpacking, installation and start up. This guide is meant to be used in conjunction with the *SmartMotor™ Developer's Guide*, which describes the SmartMotor features, SMI software, programming, commands, and other topics related to SmartMotor application development.

**NOTE:** The features described in this guide apply to the Class 6 D-style SmartMotor with firmware version 6.4.x.x (6.4.2.54 or later is recommended). Additionally, those motors require SMI software version 3.0.0.73 or later for complete feature support.



*Class 6 D-Style SmartMotor*

The information in this guide is meant to be used by properly trained technical personnel only. Moog Animatics conducts classroom-style SmartMotor training several times per year, as well as product seminars and other training opportunities. For more information, please see the Moog Animatics website or contact your Moog Animatics representative.

## Combitronic Technology

The most unique feature of the SmartMotor is its ability to communicate with other SmartMotors and share resources using Moog Animatics' Combitronic™ technology. Combitronic is a protocol that operates over a standard CAN interface. It may coexist with the CANopen protocol. It requires no single dedicated controller<sup>1</sup> to operate. Each SmartMotor connected to the same network communicates on an equal footing, sharing all information, and therefore, sharing all processing resources.

**NOTE:** Combitronic over Ethernet, which allows Combitronic communication on the Industrial Ethernet network, is not currently available on the Class 6 D-style SmartMotor.

For additional details, see the *SmartMotor™ Developer's Guide*.

---

<sup>1</sup>Moog Animatics has replaced the terms "master" and "slave" with "controller" and "follower", respectively.

## I/O Device CAN Bus Controller

Expanded I/O capability allows the SmartMotor to interface with standard CiA 301 CANopen devices and function as the I/O device CAN bus controller (i.e., no external bus controller is needed). For more details, see the *SmartMotor™ Developer's Guide*. For CANopen object descriptions, see the *SmartMotor™ CANopen Guide*.

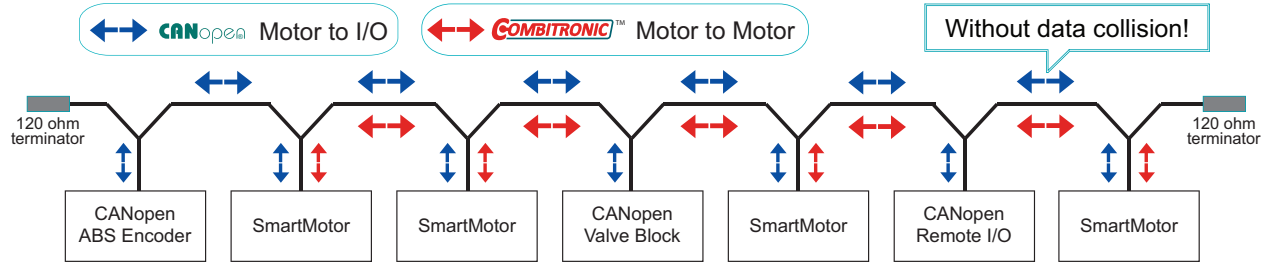

Be sure to comply with the guidelines for CAN bus cabling and termination.

### SmartMotor as I/O Device CAN Bus Controller

## Safety Information

This section describes the safety symbols and other safety information.

### Safety Symbols

The manual may use one or more of these safety symbols:



**WARNING:** This symbol indicates a potentially nonlethal mechanical hazard, where failure to comply with the instructions could result in serious injury to the operator or major damage to the equipment.

---



**CAUTION:** This symbol indicates a potentially minor hazard, where failure to comply with the instructions could result in slight injury to the operator or minor damage to the equipment.

---

**NOTE:** Notes are used to emphasize non-safety concepts or related information.

### Other Safety Considerations

The Moog Animatics SmartMotors are supplied as components that are intended for use in an automated machine or system. As such, it is beyond the scope of this manual to attempt to cover all the safety standards and considerations that are part of the overall machine/system design and manufacturing safety. Therefore, this information is intended to be used only as a general guideline for the machine/system designer.

It is the responsibility of the machine/system designer to perform a thorough "Risk Assessment" and to ensure that the machine/system and its safeguards comply with the safety standards specified by the governing authority (for example, ISO, OSHA, UL, etc.) for the site where the machine is being installed and operated. For more details, see Machine Safety on page 10.

### Motor Sizing

It is the responsibility of the machine/system designer to select SmartMotors that are properly sized for the specific application. Undersized motors may: perform poorly, cause excessive downtime or cause unsafe operating conditions by not being able to handle the loads placed on them. The *System Best Practices* document, which is available on the Moog Animatics website, contains information and equations that can be used for selecting the appropriate motor for the application.

Replacement motors must have the same specifications and firmware version used in the approved and validated system. Specification changes or firmware upgrades require the approval of the system designer and may require another Risk Assessment.

### Environmental Considerations

It is the responsibility of the machine/system designer to evaluate the intended operating environment for dust, high-humidity or presence of water (for example, a food-processing environment that requires water or steam wash down of equipment), corrosives or chemicals that may come in contact with the machine, etc. Moog Animatics manufactures specialized IP-rated motors for operating in extreme conditions. For details, see the *Moog Animatics Product Catalog*.

## Machine Safety

In order to protect personnel from any safety hazards in the machine or system, the machine/system builder must perform a "Risk Assessment", which is often based on the ISO 13849 standard. The design/implementation of barriers, emergency stop (E-stop) mechanisms and other safeguards will be driven by the Risk Assessment and the safety standards specified by the governing authority (for example, ISO, OSHA, UL, etc.) for the site where the machine is being installed and operated. The methodology and details of such an assessment are beyond the scope of this manual. However, there are various sources of Risk Assessment information available in print and on the internet.

**NOTE:** The next list is an example of items that would be evaluated when performing the Risk Assessment. Additional items may be required. The safeguards must ensure the safety of all personnel who may come in contact with or be in the vicinity of the machine.

In general, the machine/system safeguards must:

- Provide a barrier to prevent unauthorized entry or access to the machine or system. The barrier must be designed so that personnel cannot reach into any identified danger zones.
- Position the control panel so that it is outside the barrier area but located for an unrestricted view of the moving mechanism. The control panel must include an E-stop mechanism. Buttons that start the machine must be protected from accidental activation.
- Provide E-stop mechanisms located at the control panel and at other points around the perimeter of the barrier that will stop all machine movement when tripped.
- Provide appropriate sensors and interlocks on gates or other points of entry into the protected zone that will stop all machine movement when tripped.
- Ensure that if a portable control/programming device is supplied (for example, a hand-held operator/programmer pendant), the device is equipped with an E-stop mechanism.

**NOTE:** A portable operation/programming device requires *many* additional system design considerations and safeguards beyond those listed in this section. For details, see the safety standards specified by the governing authority (for example, ISO, OSHA, UL, etc.) for the site where the machine is being installed and operated.

- Prevent contact with moving mechanisms (for example, arms, gears, belts, pulleys, tooling, etc.).
- Prevent contact with a part that is thrown from the machine tooling or other part-handling equipment.
- Prevent contact with any electrical, hydraulic, pneumatic, thermal, chemical or other hazards that may be present at the machine.
- Prevent unauthorized access to wiring and power-supply cabinets, electrical boxes, etc.
- Provide a proper control system, program logic and error checking to ensure the safety of all personnel and equipment (for example, to prevent a run-away condition). The control system must be designed so that it does not automatically restart the machine/system after a power failure.
- Prevent unauthorized access or changes to the control system or software.

## Documentation and Training

It is the responsibility of the machine/system designer to provide documentation on safety, operation, maintenance and programming, along with training for all machine operators, maintenance technicians, programmers, and other personnel who may have access to the machine. This documentation must include proper lockout/tagout procedures for maintenance and programming operations.

It is the responsibility of the operating company to ensure that:

- All operators, maintenance technicians, programmers and other personnel are tested and qualified before acquiring access to the machine or system.
- The above personnel perform their assigned functions in a responsible and safe manner to comply with the procedures in the supplied documentation and the company safety practices.
- The equipment is maintained as described in the documentation and training supplied by the machine/system designer.

### Additional Equipment and Considerations

The Risk Assessment and the operating company's standard safety policies will dictate the need for additional equipment. In general, it is the responsibility of the operating company to ensure that:

- Unauthorized access to the machine is prevented at all times.
- The personnel are supplied with the proper equipment for the environment and their job functions, which may include: safety glasses, hearing protection, safety footwear, smocks or aprons, gloves, hard hats and other protective gear.
- The work area is equipped with proper safety equipment such as first aid equipment, fire suppression equipment, emergency eye wash and full-body wash stations, etc.
- There are no modifications made to the machine or system without proper engineering evaluation for design, safety, reliability, etc., and a Risk Assessment.

### Safety Information Resources

Additional SmartMotor safety information can be found on the Moog Animatics website; open the topic "Controls - Notes and Cautions" located at:

<https://www.animatics.com/support/downloads/knowledgebase/controls---notes-and-cautions.html>

OSHA standards information can be found at:

<https://www.osha.gov/law-regs.html>

ANSI-RIA robotic safety information can be found at:

<http://www.robotics.org/robotic-content.cfm/Robotics/Safety-Compliance/id/23>

UL standards information can be found at:

<http://ulstandards.ul.com/standards-catalog/>

ISO standards information can be found at:

<http://www.iso.org/iso/home/standards.htm>

EU standards information can be found at:

[http://ec.europa.eu/growth/single-market/european-standards/harmonised-standards/index\\_en.htm](http://ec.europa.eu/growth/single-market/european-standards/harmonised-standards/index_en.htm)

### Additional Documents

The Moog Animatics website contains additional documents that are related to the information in this manual. Please refer to these lists.

## Related Guides

- *SmartMotor™ Developer's Guide*  
<http://www.animatics.com/smartmotor-developers-guide>
- *SmartMotor™ Homing Procedures and Methods Application Note*  
<http://www.animatics.com/homing-application-note>
- *SmartMotor™ System Best Practices Application Note*  
<http://www.animatics.com/system-best-practices-application-note>

In addition to the documents listed above, guides for fieldbus protocols and more can be found on the website: <https://www.animatics.com/support/downloads.manuals.html>

## Other Documents

- SmartMotor™ Certifications  
<https://www.animatics.com/certifications.html>
- *SmartMotor Developer's Worksheet*  
(interactive tools to assist developer: Scale Factor Calculator, Status Words, CAN Port Status, Serial Port Status, RMODE Decoder and Syntax Error Codes)  
<https://www.animatics.com/support/downloads.knowledgebase.html>
- *Moog Animatics Product Catalog*  
<http://www.animatics.com/support/moog-animatics-catalog.html>

## Additional Resources

The Moog Animatics website contains useful resources such as product information, documentation, product support and more. Please refer to these addresses:

- General company information:  
<http://www.animatics.com>
- Product information:  
<http://www.animatics.com/products.html>
- Product support (Downloads, How-to Videos, Forums and more):  
<http://www.animatics.com/support.html>
- Contact information, distributor locator tool, inquiries:  
<https://www.animatics.com/contact-us.html>

- Applications (Application Notes and Case Studies):

<http://www.animatics.com/applications.html>

# SmartMotor Overview

This chapter provides an overview of the design philosophy and functionality of the Moog Animatics SmartMotor. It also provides information on SmartMotor features and options, and where to find related documents and additional resources.

<b>SmartMotor Introduction</b> .....	<b>15</b>
<b>SmartMotor Features and Options</b> .....	<b>15</b>
Class 6 D-Style Motors .....	16
Standard Features .....	16
Optional Features .....	17
Connectors and LED Locations .....	17
Fieldbus Options .....	18
CANopen Fieldbus Protocol .....	18
EtherCAT Fieldbus Protocol .....	18
PROFINET Fieldbus Protocol .....	19
EtherNet/IP Fieldbus Protocol .....	19
Dual Power Configuration .....	21
<b>SmartMotor Theory of Operation</b> .....	<b>22</b>

## SmartMotor Introduction

The Moog Animatics SmartMotor™ servo is an industrial servo motor with motion controller integrated into a compact package. Its design is based on these objectives:

1. Reduce development time
2. Lower machine-production cost
3. Simplify the machine (design, build and support)



*Class 6 D-Style SmartMotor with Industrial Ethernet and Inline Brake Options*

The SmartMotor is powerful and unique because of its ability to control an entire machine. The combination of programmability, networking, I/O and servo performance is unmatched. The SmartMotor brings savings and value to the machine builder by removing complex and costly elements in the machine design, such as PLCs, sensors, I/O blocks, cabinets, etc.

## SmartMotor Features and Options

**NOTE:** All specifications are subject to change without notice. Consult the factory for the latest information.

The Class 6 D-style SmartMotor is available only in a D-style configuration. All SmartMotors offer these features:

- Full floating-point math and trigonometric functions with 32-bit precision results
- Dual trajectory generators enabling relative and absolute position moves or velocity moves on top of gearing or camming
- Advanced gearing allowing preset traverse and take-up winding parameters including dwells and wrap counts
- Advanced camming including cubic spline interpolation and dynamic frequency and amplitude changes. Add onto gearing for complex traverse and take-up winding patterns.
- Stand-alone, multi-axis linear interpolation with as many as 120 SmartMotors at a time

- Virtual-axis control into camming through gearing, which enables stand-alone, multi-axis coordinated motion
- Programmable and non-programmable protection features (both hardware and software)

***A note about SmartMotor part numbers:***

The SmartMotor uses a coded part number, which contains characters that describe the motor number, frame style and options. For details on decoding the SmartMotor part number, refer to the Understanding SmartMotor Part Numbers document at this address:

<https://www.animatics.com/support/downloads.knowledgebase.html>

## Class 6 D-Style Motors

The Class 6 SmartMotor is available in an D-style configuration.

### Standard Features

All Class 6 D-style SmartMotors have these standard features:

- Batteryless (and gearless) absolute multiturn encoder, no battery backup needed, see Batteryless Absolute Multiturn Encoder on page 64
- High density 26-pin (the "HD26") connector in a DA shell, supports additional I/O and more communications options
- Ten channels of expanded, industry standard 24 VDC I/O (I/O 0 - 9)
- Dedicated Drive-Enable input and NOT-FAULT output
- Single or dual (separated) drive and control power input, both are standard and enabled automatically depending on power connection(s)
- Differential encoder input for reduced interference from electrically noisy environments
- 105 °C upper operating temperature limit for higher torque output
- LEDs: Bi-colored LED indicators to show error codes, provide network status and communications activity
- CAN over D-Sub (CDS) and 7W2 (CDS7) connectors
- Communications: RS-232, RS-485, Combitronic, USB, Ethernet, CAN bus, with no loss in I/O
- Upgraded processors (as compared to Class 5) with higher clock speeds, more RAM and EEPROM, resulting in more space for more complex user programs, faster program execution, and built in homing functions
- SMI software available, optionally used for application development and debugging
- I/O support for Drive Enable, Position Limits and Fault status
- Motor sample rate: 16 kHz
- Position Capture Register from signal-ended, ground-referenced external input (non-differential)
- External encoder input supporting either A-quad-B or Step-and-Direction modes of counting
  - Machine Line Shaft Input support
  - Maximum individual line frequency at either the A or B input is 1.5 MHz

All firmware options include:

- Modbus Remote Terminal Unit (RTU) Follower (RS-485 COM 1), see the *SmartMotor™ Modbus RTU Guide*
- DMX Follower (RS-485 COM 1), see the *SmartMotor™ DMX Guide*

## Optional Features

These Class 6 D-style features are optional:

**NOTE:** These options can be ordered individually or combined.

- Inline brake option (available on all frame sizes)
- Industrial Ethernet with dual-port switch (available on all frame sizes) – see the available fieldbus communications protocols below
- "DT" high torque option, applies to SM23166, SM23266, SM23376, SM34166, SM34266 models - contact Moog Animatics for details
- Shaft options such as 1 or 2 flats, or keyed - contact Moog Animatics for details

These fieldbus communications protocols are available on the Class 6 D-style motors.

**NOTE:** These fieldbus protocols require the Industrial Ethernet option.

- EtherNet/IP (-EIP) option
- EtherCAT (-EEC) option
- PROFINET (-EPN) option

The Class 6 D-style motors are available in these NEMA frame sizes:

- NEMA 17
- NEMA 23
- NEMA 34

For additional information on SmartMotor features, specifications, torque curves and more, see the corresponding SmartMotor product page for your motor. SmartMotor product pages are available from the Products menu on the Moog Animatics website.

## Connectors and LED Locations

The next figure shows the connector and LED location for the Class 6 D-style SmartMotor. For details on the motor connectors, see *Connecting the System* on page 34. For details on the LED functions, see *Understanding the Status LEDs* on page 45.



**CAUTION:** For Class 6 D-style SmartMotors, pins 11 and 12 of the 26-pin D-sub port are intended for control power only. Attempts to power a motor through those pins as main servo drive power could result in immediate damage to the electronics and will void the warranty.

---

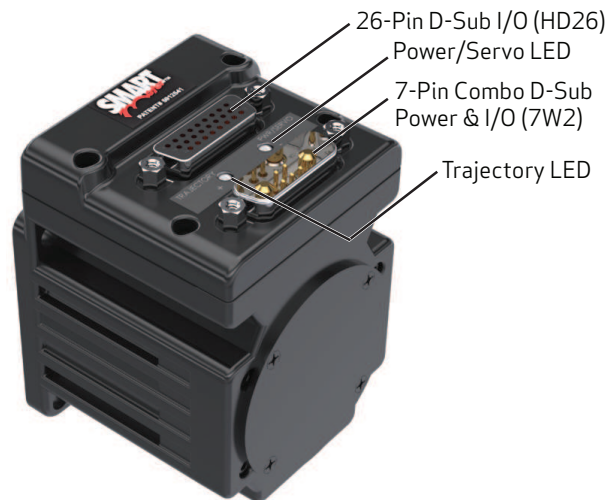

*Class 6 D-Style Motor Connectors and LEDs*

## Fieldbus Options

This section details the Fieldbus communications protocol options that are available on Class 6 D-style SmartMotors.

### CANopen Fieldbus Protocol

**NOTE:** This protocol is a standard feature on the Class 6 D-style SmartMotor.

The CANopen fieldbus protocol provides these features:

- Basic motion commands available through the CiA V4.02 specification
- Ability to read/write SmartMotor variables
- Use of onboard I/O through CANopen, SmartMotor programs or serial commands
- Ability to run 1000 SmartMotor subroutines through CANopen
- Online diagnostics of the SmartMotor through SMI software and serial connection
- Logical addressing for 127 nodes
- User program status/interrupts can be triggered by receive PDOs
- Baud rates of 20 Kbps, 50 Kbps, 125 Kbps (default), 250 Kbps, 500 Kbps and 1 Mbps
- Expanded I/O capability allows the SmartMotor to interface with standard CiA 301 CANopen devices and function as the I/O device CAN bus controller (i.e., no external bus controller is needed). For more details, see the *SmartMotor™ Developer's Guide*. For CANopen object descriptions, see the *SmartMotor™ CANopen Guide*.

**NOTE:** For the Class 6 D-style SmartMotor, there is no separate CAN connector on the back of the motor. CAN bus connections are available on both the 7-pin and HD26-pin connectors. For details, see CDS Schematic on page 39.

For more details, see the *SmartMotor™ CANopen Guide*.

### EtherCAT Fieldbus Protocol

**NOTE:** This fieldbus protocol is optionally available on Class 6 D-style motors.

The EtherCAT fieldbus protocol provides these features:

- Command/Response Codes for SmartMotor commands
- CiA 402 Motion Modes: Profile Position (PP), Profile Velocity (PV), Torque (TQ), Cyclic Sync Position (CSP), Cyclic Sync Velocity (CSV), Cyclic Sync Torque (CST)
- Dynamic PDO mapping
- Configurable Sync Manager 2 and 3 assignment
- DC-sync Subordinate mode with SYNC0 and SYNC1
- DC-sync follower
- Selectable Homing modes (with or without index pulse)
- Selectable Interpolation modes (spline or linear)
- Touch Probe function allows the motor's position to be captured on a specific event

For the EtherCAT connector diagram and pinouts, see Industrial Ethernet Network on page 43.

For more details, see the *Class 6 SmartMotor EtherCAT Guide*.

### PROFINET Fieldbus Protocol

**NOTE:** This fieldbus protocol is optionally available on Class 6 D-style motors.

The PROFINET fieldbus protocol provides these features:

- Command/response codes for SmartMotor commands
- Use of on-board I/O through PROFINET, SmartMotor program, or RS-485 commands
- The Moog Animatics communications profile over PROFINET is intended to integrate well with a PLC that continuously transmits and receives cyclic data; the command and response codes achieve this through a handshaking mechanism

For the PROFINET connector diagram and pinouts, see Industrial Ethernet Network on page 43.

For more details, see the *Class 6 SmartMotor™ PROFINET Guide*.

### EtherNet/IP Fieldbus Protocol

**NOTE:** This fieldbus protocol is optionally available on Class 6 D-style motors.

The EtherNet/IP fieldbus protocol provides these features:

- Access to unique SmartMotor commands and parameters.
- Use of on-board I/O through EtherNet/IP, SmartMotor program, or RS-485 commands
- The Moog Animatics communications profile over EtherNet/IP is intended to integrate well with a PLC that continuously transmits and receives cyclic data (implicit messaging); the command and response codes achieve this through a handshaking mechanism
- Certain configuration data is held in nonvolatile storage in the SmartMotor; therefore, the motor data EEPROM must be correctly initialized before EtherNet/IP operation
- Supports extended function CIP Position Controller Device
- Supports Modbus TCP/IP, see the *Class 6 SmartMotor™ Modbus TCP/IP Guide*

- Supports Ethernet Serial Encapsulation, see the *Class 6 SmartMotor Ethernet Serial Encapsulation Guide*
- Control modes for Profile Torque, Profile Velocity and Profile Position modes
- Change Dynamic - motion profile changes on the fly
- Implicit exchange access to many SmartMotor parameters
- Supports the SMI software Find/Detect operations over Ethernet – the SmartMotor must be previously configured (through COM or USB) with a valid IP address

For the EtherNet/IP connector diagram and pinouts, see Industrial Ethernet Network on page 43.

For more details, see the *Class 6 SmartMotor EtherNet/IP Guide*.

## Dual Power Configuration

The Class 6 D-style SmartMotor's hardware dual power configuration allows the controller and drive amplifier to be powered from separate DC power supplies (see the next figure).

**NOTE:** I/O outputs cannot be powered from the 7W2 connector.

This configuration provides these advantages:

- Controller can be powered from a +24 VDC ( $\pm 20\%$ ) 32 VDC max. power supply
- Load surges will not cause a power surge on the controller

**NOTE:** All Class 6 D-style SmartMotors are designed to allow the use of separate drive and control power supplies. No special ordering option is needed for those SmartMotors.

The next figure shows the connectors used for the dual power configuration.

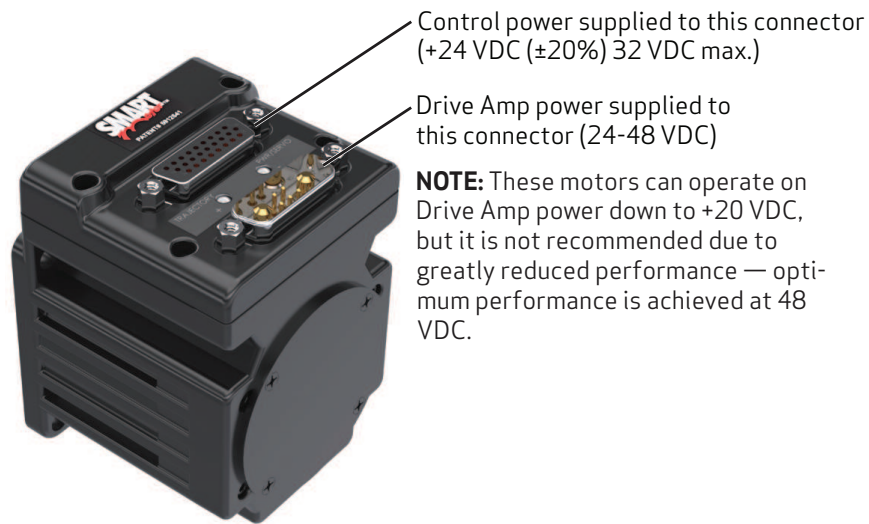

*D-Style Dual Power Configuration Drive and Control Power Connections*

Although you can supply the control and drive power from one power supply, you will only get the full benefits and maximum protection by using separate power supplies, as noted in the previous figure.

## SmartMotor Theory of Operation

The Moog Animatics SmartMotor is an entire servo control system built inside of a servo motor. It includes a controller, an amplifier and an encoder. All that is required for it to operate is power and either an internal program or serial commands from outside (or both). To make the SmartMotor move, the program or serial host must set a mode of operation, state a target position with/or a maximum velocity at which to travel to that target, and a maximum acceleration. After these three parameters are set, the two limit inputs are pulled high or deactivated, and the Drive Enable input is satisfied, a "Go" command starts the motion profile.

The core functional areas of the SmartMotor are:

- Motion Control Functions (see Motion Details in the *SmartMotor™ Developer's Guide*)
- System Control Functions (see Program Flow Details and see System Status in the *SmartMotor™ Developer's Guide*)
- Communication Functions (see Communication Details in the *SmartMotor™ Developer's Guide*)
- I/O Functions (see I/O Control in the *SmartMotor™ Developer's Guide*)

The next block diagram illustrates the relationship between the functional areas in the SmartMotor.

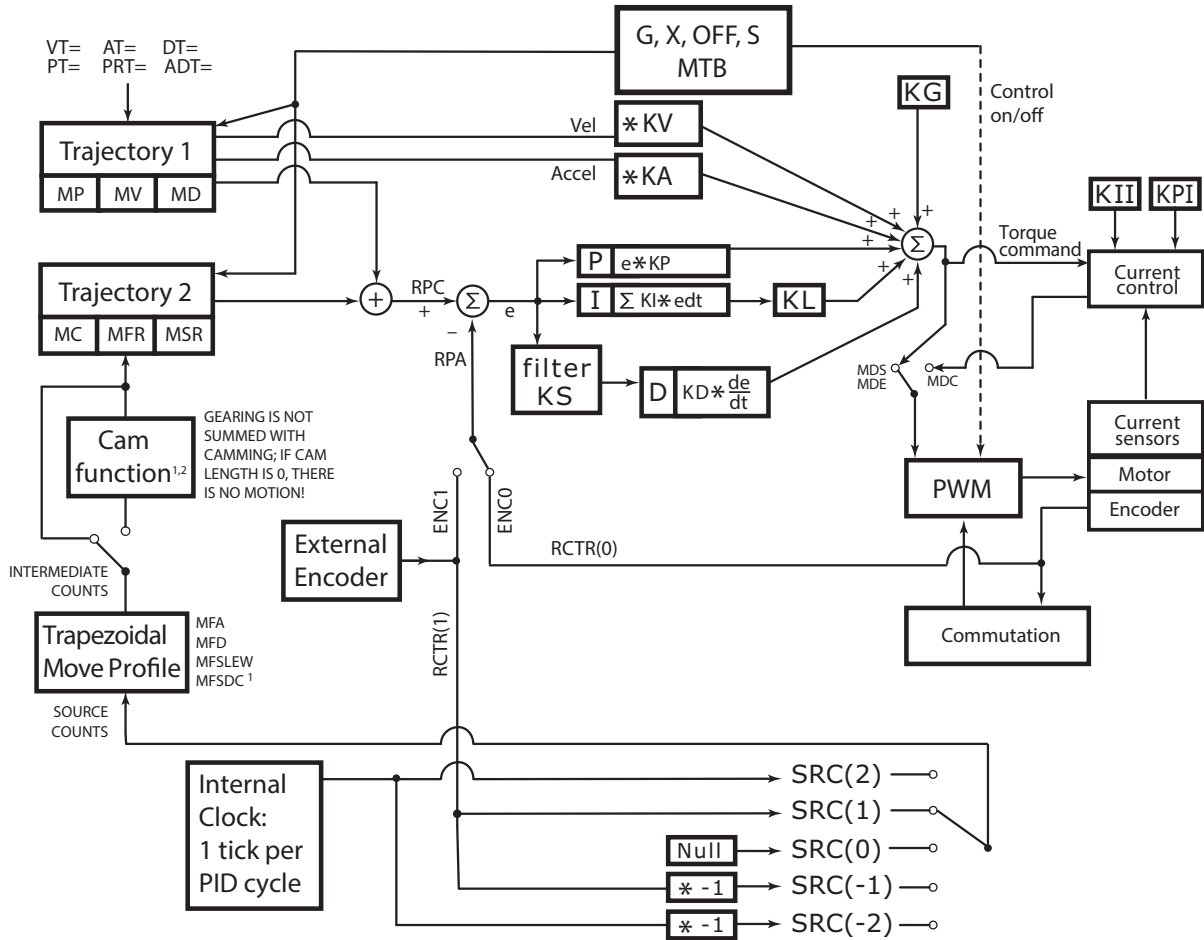

NOTES:

1. MFMUL and MFDIV commands do not have an effect on dwell time or distance. Dwell is strictly based on raw controller encoder counts selected by the SRC() command specifying internal virtual or external controller count source.
2. When feeding a Cam table with a gearing profile, changes to MFMUL and MFDIV will affect the time it takes to move through a Cam table but will not affect dwell time, as specified in the previous note.

SmartMotor Theory of Operation Diagram

# Getting Started

This chapter provides information on getting started with your SmartMotor.

<b>Unpacking and Verifying Your Shipment</b> .....	<b>26</b>
<b>Installing the SMI Software</b> .....	<b>26</b>
Installation Procedure .....	26
Installation Verification .....	29
<b>Accessing the SMI Software Interface</b> .....	<b>29</b>
<b>Understanding the Power Requirements</b> .....	<b>31</b>
SmartMotor Power Requirements .....	31
CPU, I/O and Communications Power .....	32
CPU Power Requirements .....	32
I/O Power Requirements .....	33
Communications Power Requirements .....	33
Drive Enable Input .....	33
<b>Connecting the System</b> .....	<b>34</b>
Minimum Requirements .....	34
Connectors and Pinouts .....	35
D-Style Connections At A Glance .....	35
Demo or Development System .....	36
RS-232 Through USB .....	36
Adding a USB to Serial Adapter .....	36
RS-232 with Protective Shunt .....	37
RS-232 Multidrop with Add-A-Motor Cables .....	37
USB to HD26 Connector .....	38
Dual Power Configuration .....	38
CDS Schematic .....	39
CDS on the HD26 Connector .....	39
CDS on the 7W2 Connector (CDS7) .....	40
Industrial Ethernet Network .....	43
Min and Max Cable Length .....	44
Ethernet Cables .....	44
<b>Understanding the Status LEDs</b> .....	<b>45</b>
<b>Detecting and Communicating with the SmartMotors</b> .....	<b>45</b>
Understanding the Detection and Configuration Options .....	46
Using the Find Motors Button .....	46
Using the Detect Motors Feature .....	49

<b>Checking and Clearing the Status Bits</b> .....	<b>51</b>
Polling the Motor .....	52
Clearing the Overtravel Limits and Fault Bits .....	53
<b>Moving the SmartMotor</b> .....	<b>54</b>
Making the Motor Move .....	54
Setting and Reporting Torque .....	55
<b>Checking the Motor Position</b> .....	<b>56</b>
Viewing the Motor Position with a Report Command .....	56
Viewing the Motor Position with the Motor View Tool .....	56

## Unpacking and Verifying Your Shipment

Your Moog Animatics SmartMotor and accessories are carefully assembled, tested, inspected and packed at the factory.

When you receive your shipment, you should:

- Visually inspect all shipping containers for visible signs of shipping damage. If you see damage, please notify your carrier and then contact Moog Animatics to report the problem.
- Carefully unpack each component and verify the part number with your order. If there are any differences or missing items, please contact Moog Animatics so that the shipment can be corrected.
- Keep all boxes and packing materials. These may be needed for future storage or shipment of the equipment.

## Installing the SMI Software

The SmartMotor Interface software (SMI software) provides a convenient user interface for programming the SmartMotor. Before you can use the SMI software, it must be installed on a Microsoft Windows PC.

The SMI software is distributed on CD-ROM or USB stick, and is also available as a download from the Moog Animatics website. To download the latest version of the SMI software, use this address:

<http://www.animatics.com/smi>

Then scroll to the bottom of the page and click the Free Download button.



*SMI Download Button*

The installation package is downloaded to your system.

**NOTE:** The SMI software requires Microsoft Windows XP or later.

### Installation Procedure

**NOTE:** Depending on the SMI software version and SmartMotor model being used, the software version and motor information may be different on your screens.

To install the SMI software:

1. Double-click the executable package (.MSI) file to begin the installation. In some versions of Microsoft Windows, you may receive a security warning message about running the file. You can ignore this message.

If this is a new installation, go to the next step.

If this is an upgrade to a previous installation, you will see the window below. Select Remove, click Next and remove the existing software from your PC using the instructions.

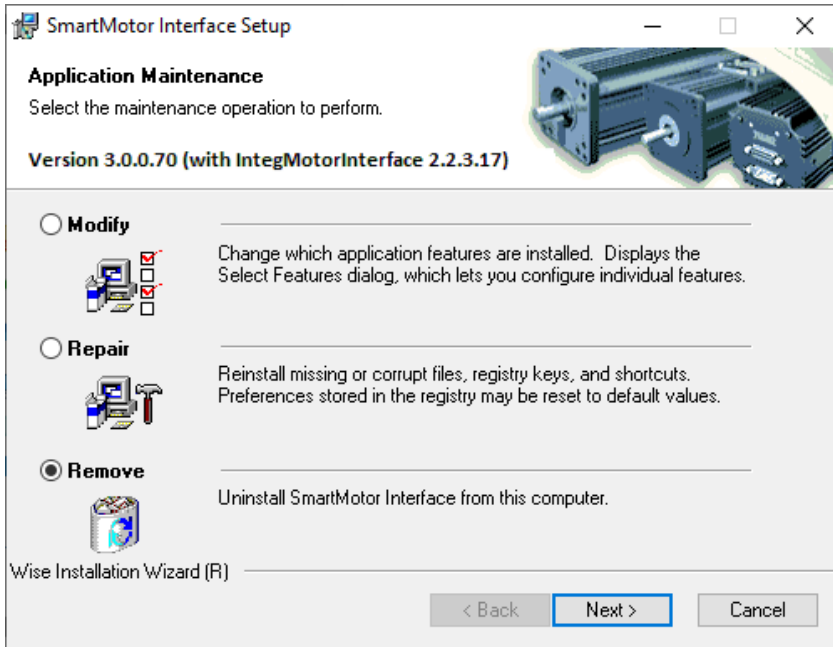

After removing the existing software, restart the installation process.

**NOTE:** All personal settings and user files will be retained.

2. Click Next to proceed. The Installation Configuration page opens.

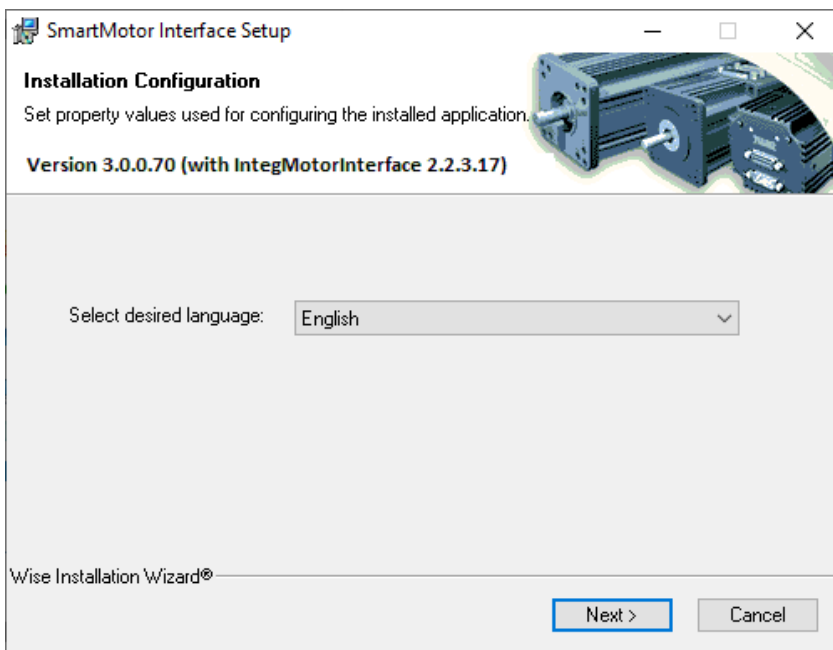

3. Click Next to proceed. The SMI software installation wizard starts and the Welcome page opens.

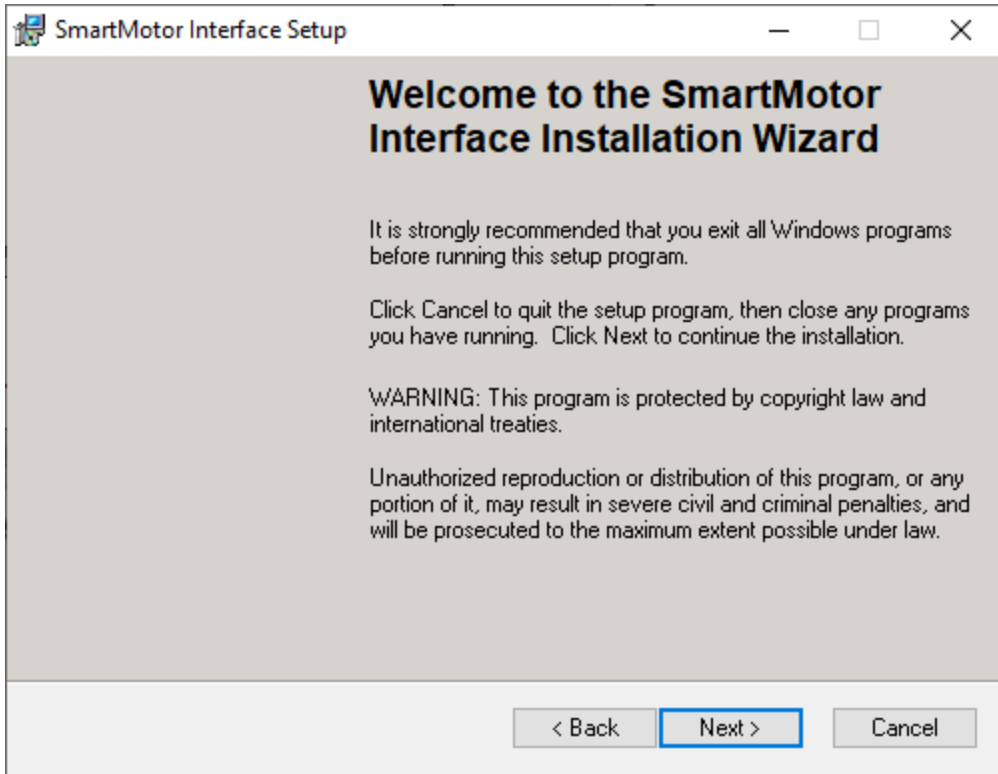

4. After you have finished reviewing the welcome information, click Next to proceed. Use the on-screen instructions to complete the SMI software installation.

- When the installation has completed, the installation status message page opens, as shown in the next figure. Click Finish to complete the installation and close the installation wizard.

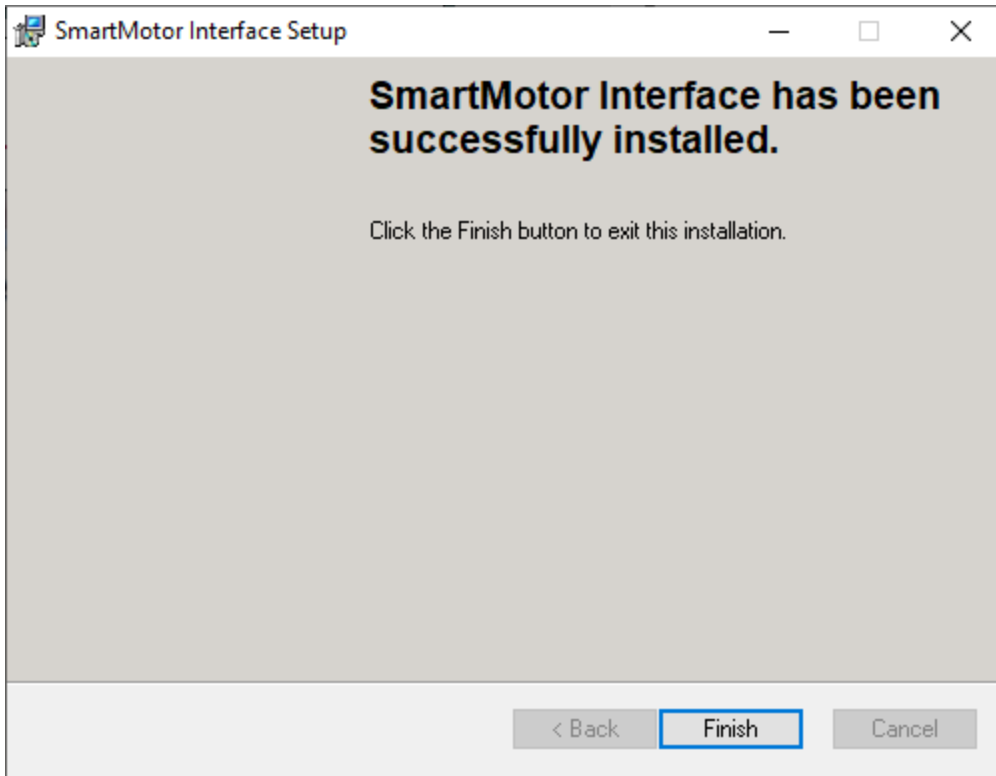

**NOTE:** After the software is installed, be sure to restart your computer before running the SMI software.

## Installation Verification

To verify the installation, navigate to the C:\Program Files (or folder C:\Program Files x86) folder. You should see these folders:

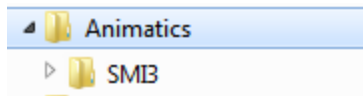

## Accessing the SMI Software Interface

The SmartMotor Interface software (SMI software) communicates with a single or series of SmartMotors from a Windows-based PC and gives you the capability to control and monitor the status of the motors. The SMI software also allows you to write programs and download them into the SmartMotor's long-term memory.

**NOTE:** Every SmartMotor has an ASCII interpreter built in. Therefore, it is not necessary to use the SMI software to operate a SmartMotor.

To open the SMI software, double-click the SmartMotor Interface shortcut on the Windows desktop.



*SmartMotor Interface Shortcut*

Optionally, to open the SMI software from the Microsoft Windows Start menu, select:

**Start > All Programs > Animatics > SMI3 > SmartMotor Interface**

The SMI software interface opens, as shown in the next figure.

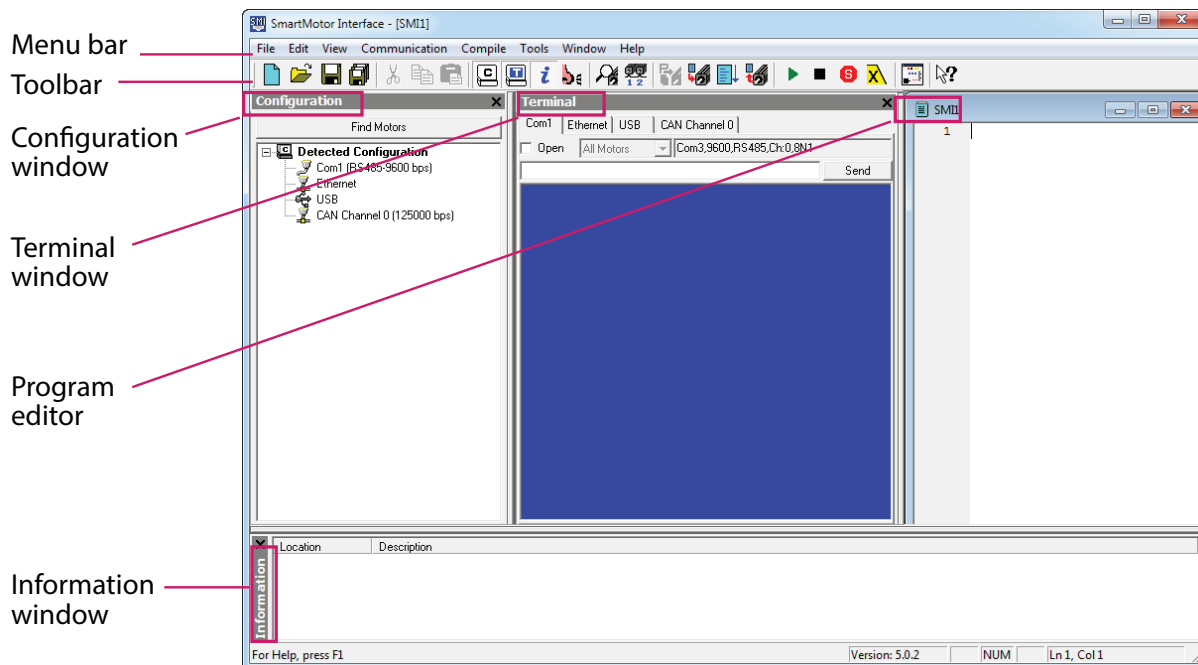

*SMI Software Interface*

**NOTE:** In addition to the software information in this section, there is context-sensitive help available within the SMI software interface, which is accessed by pressing the F1 key or selecting Help from the SMI software main menu.

These are the primary features in this interface:

- **Menu Bar:** All of the windows and functions of the SMI software can be accessed through the menu bar. Many of these are also accessible through the icons on the toolbar.
- **Toolbar:** The toolbar contains a collection of icons for accessing the primary features of the SMI software. Depending on the current state of the SMI software and the currently-active window, some toolbar buttons may be disabled.
- **Configuration Window (far-left window):** This window is used to display the current communication and detected motor configuration when no project is open, or the communication and motor configuration defined in an open project.
- **Terminal Window (middle window):** This window is used to communicate with SmartMotors (for example, issue single-line commands to one or all motors). The response (if any) is also shown in this window.
- **Information Window (lower window):** This window is used to display the results of user operations.
- **Program Editor (far-right window):** This window is used to manage, edit and print user programs. Most of the procedures for using the editor should seem familiar if you have used other Windows-based text editors.

For more details about these items, see the SMI software online help, which can be viewed in SMI by pressing F1 or selecting Help > Contents - SMI Software Help.

## Understanding the Power Requirements

This section describes the power requirements for Class 6 D-Style SmartMotor power, CPU power, I/O power and Communications power.

### SmartMotor Power Requirements



**CAUTION:** If power is reversed on any standard SmartMotor, immediate damage WILL occur and the SmartMotor will no longer operate.

#### Requirement:

For Class 6 D-Style SmartMotors, there are two options: 1) power the entire motor (drive and control) from the main input on the 7W2 connector, or 2) the recommended "dual power" method, power the drive stage through the 7W2 connector and power the controller through the HD26 D-sub connector. Refer to the next figure. For more details on the dual power configuration, see Dual Power Configuration on page 38.

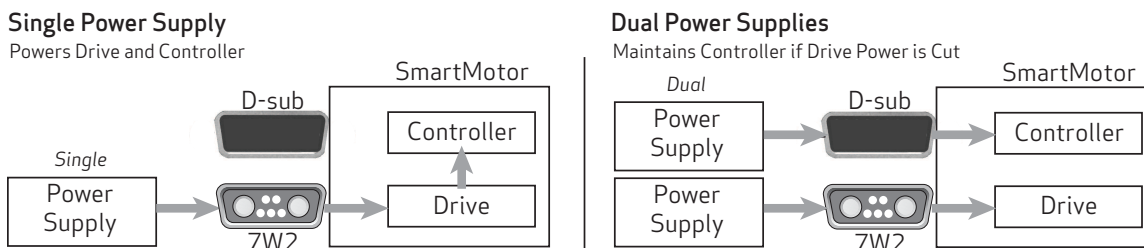

Single vs. Dual Power Configuration



**CAUTION:** Control power for Class 6 D-Style motors must be nominal 24 VDC ( $\pm 20\%$ ). They are not rated for 48 VDC.

Control power requires nominal 24 VDC ( $\pm 20\%$ ), do not exceed 32 VDC; motor power requires from 24 VDC to 48 VDC, do not exceed 48 VDC. Also, note that:

- If I/Os are used, the control power pins must be supplied with power, as those pins provide signal power for the I/O, see I/O Power Requirements on page 33.
- If the brake option is installed, brake power is supplied by the drive power input on the 7W2 connector. Therefore,
  - If drive power is lost, the brake will de-energize and hold the shaft.
  - If control power is not supplied on the HD26 connector, but is supplied through the 7W2 connector, the brake will still work.

**NOTE:** These motors can operate on power down to +20 VDC, but it is not recommended due to greatly reduced performance -- optimum performance is achieved at 48 VDC.

**Details:** Large SmartMotors can draw high current. Therefore, heavy gauge wire is required to connect the large motors.

Voltages below 18 VDC could cause a brownout shutdown of the CPU, or what would appear as a power-off reset, under sudden load changes.

When relying on torque/speed curves, pay close attention to the voltage on which they are based.

During hard, fast decelerations, a SmartMotor can pull up supply voltages to the point of damage if a shunt resistor pack is not used. Protective shunts are available from Moog Animatics.



**CAUTION:** Many vertical applications and applications with hard, fast decelerations require shunts to protect the SmartMotor from damage. Note that shunts should always be placed between the motor input and any disconnect or E-stop relay to protect the motor when power is off or E-stop relay contacts are open.

Special care must be taken when near the upper voltage limit or in vertical applications that can back-drive the SmartMotor. Gravity-influenced applications can turn the SmartMotor into a generator and back-drive the power supply voltage above the safe limit for the SmartMotor. Many vertical applications require a shunt to protect the SmartMotor from damage. Protective shunts are available from Moog Animatics.

## CPU, I/O and Communications Power



**CAUTION:** The maximum allowed supply voltage is 32 VDC. Voltages greater than the maximum value will damage the equipment.

The CPU can be powered directly from the drive (single power configuration), or it can be powered separately from the drive (dual power configuration). For details, see the discussion earlier in this topic, and also see Dual Power Configuration on page 38.

For dual power configurations, the HD26 control power input pins can draw 24 VDC @ 650 mA in total (CPU power and I/O power), see the next two sections for details. If the Ethernet option is included, it uses an additional 100 mA, see the next figure.

**NOTE:** If control power is not supplied on the HD26 input (pin 11), outputs will not be able to be driven. However, all inputs can still be detected.

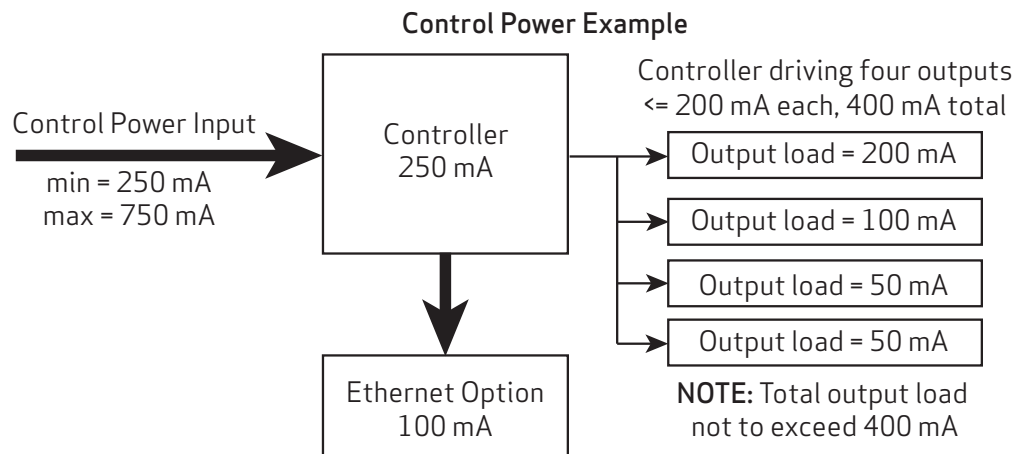

## CPU Power Requirements

For dual power configurations, where the controller and drive are each powered separately, the user-supplied 24 VDC controller power supply should be capable of handling up to 6 watts (250 mA) for the CPU alone; see the next section for additional I/O power requirements.

**Requirement:** Nominal 24 VDC (range 18-32 V) @ 250mA must be supplied. Do not exceed 32 VDC.

**Details:** Power is supplied from the "control" power input (pin 11) on the HD26-pin D-sub connector.

## I/O Power Requirements

**Requirement:** Nominal 24 VDC (range 18-32 V) @ 400 mA must be supplied. Do not exceed 32 VDC.

**Details:** Power is supplied from the "control" power input (pin 11) on the HD26-pin D-sub connector.

**NOTE:** This I/O is not isolated from the CPU's power supply and the motor drive.

**NOTE:** Unlike the M-style, the D-style does not provide 24 VDC Control/IO output power.

### **Specifications:**

**NOTE:** All specifications assume nominal 24 VDC (range 18-32 V) Control power. The maximum allowed supply voltage is 32 VDC. Voltages greater than the maximum value will damage the motor.

### Input Pins Electrical Specification:

- Input Voltage Low Level Threshold: 3.6 V maximum
- Input Voltage High Level Threshold: 6.0 V minimum

### Output Pins Electrical Specification:

- Output Loading:
  - Nominal load: 200 mA each
  - Maximum load: not to exceed 400 mA total (all outputs combined)
- Output voltage: 23 V maximum load

## Communications Power Requirements

**Requirement:** Nominal 24 VDC (range 18-32 V) must be supplied. Do not exceed 32 VDC.

**Details:** Power is supplied from the "control" power input (pin 11) on the HD26-pin D-sub connector.

**NOTE:** The RS-485 signal is not isolated from the CPU's power supply or the motor drive.

## Drive Enable Input

The Drive Enable input (HD26, pin 8) must be connected and activated with 24V. For the input location, see Connectors and Pinouts on page 35.

## Connecting the System

The topics listed below show system connections and cable diagrams for typical Class 6 D-style motor installations. For connector specifications, I/O and Channel information, and example I/O connections, see Connectors, Pinouts and Examples on page 58.

For Class 6 D-style motors:

- Connectors and Pinouts on page 35
- Demo or Development System on page 36
- RS-232 Through USB on page 36
- RS-232 with Protective Shunt on page 37
- RS-232 Multidrop with Add-A-Motor Cables on page 37
- USB to HD26 Connector on page 38
- Dual Power Configuration on page 38

As you can see, many configurations are possible.

- If you are installing one of these typical configurations and Moog Animatics-supplied cables, simply use the connection information in this section.
- If you are using your own cables or a non-typical configuration, review the information in this section and also see Connectors, Pinouts and Examples on page 58.

Advanced communication information is available in Communication Details in the *SmartMotor™ Developer's Guide*.

## Minimum Requirements

At minimum, you will need these items:

1. A Class 6 D-Style SmartMotor
2. A computer running Microsoft Windows and the SMI software
3. A DC power supply and power cable for the SmartMotor
4. A data cable to connect the SmartMotor to the computer's serial port or through a USB to serial adapter, see D-Style Connections At A Glance on page 35.

OR a USB cable to connect the SmartMotor to the computer's USB port, see USB to HD26 Connector on page 38,

OR if your SmartMotor is equipped with the Ethernet option, a Cat 5 (or better) Ethernet cable to connect the motor to the computer's Ethernet port, see Industrial Ethernet Network on page 43.

## Connectors and Pinouts

The next figure provides a brief overview of the connectors and pinouts available on the D-style SmartMotors. For full details, see Class 6 D-Style Connector Pinouts on page 59.

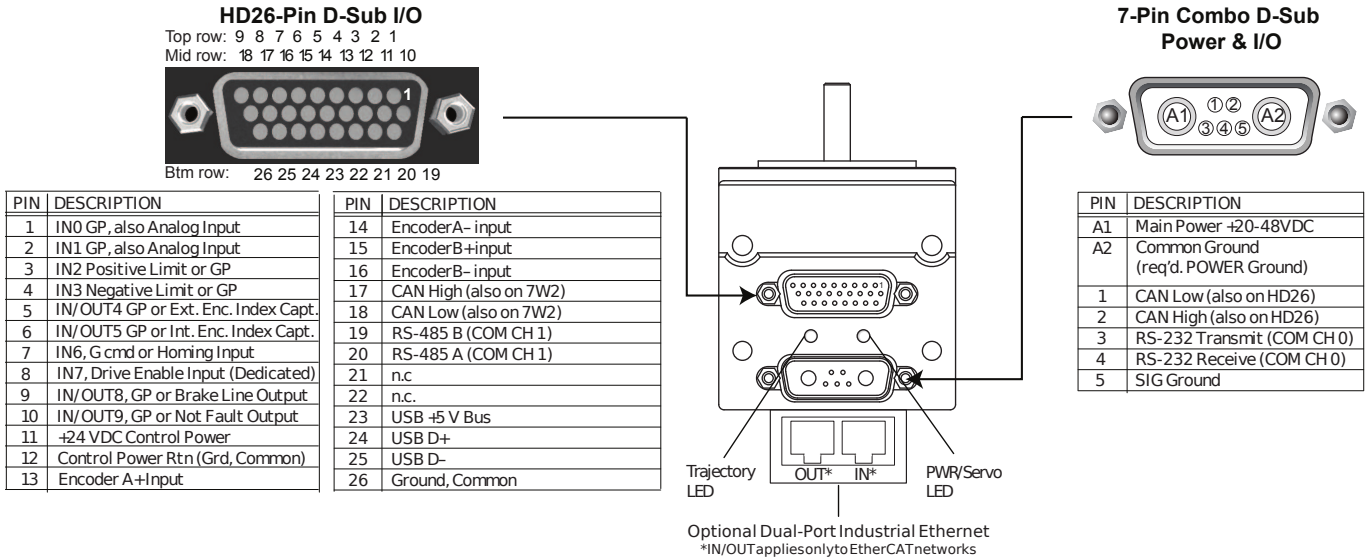

**NOTE:** The dual power configuration is recommended. For details, see Dual Power Configuration on page 38.

## D-Style Connections At A Glance

The next figure provides a quick overview of the cables and connections for the Class 6 D-style motor.

**NOTE:** The USB connection on CBLHD26-ASM is meant only for programming from the SMI software; it is not recommended for running the motor.

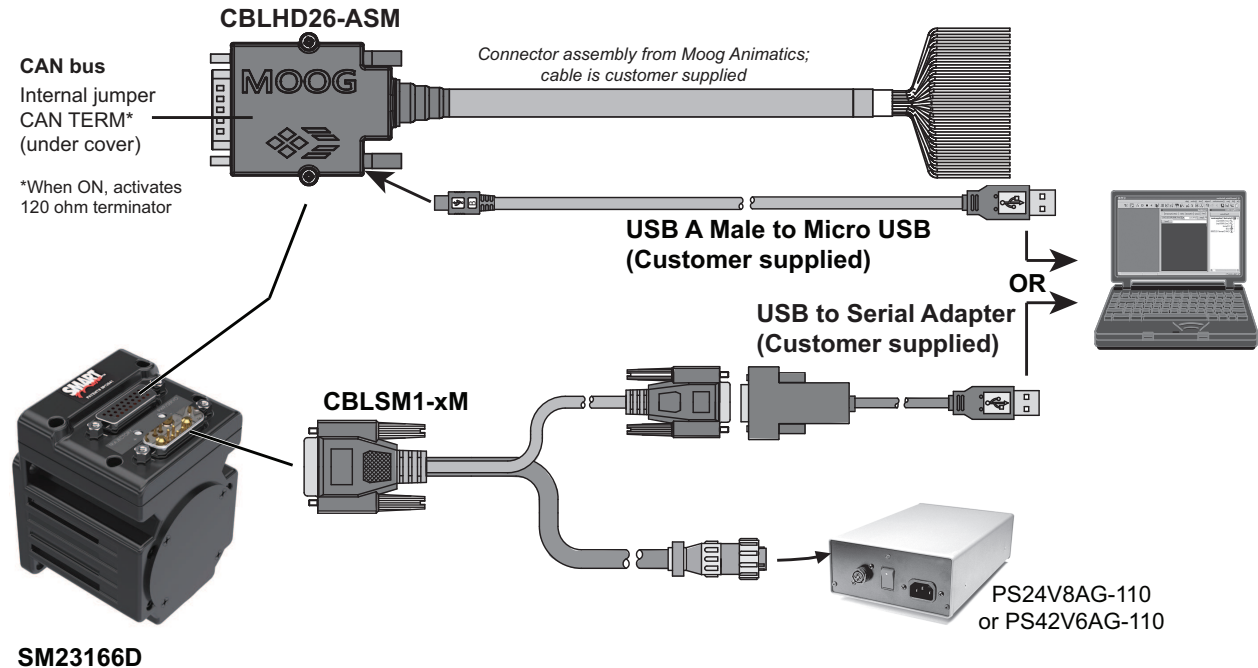

## Demo or Development System



**CAUTION:** This configuration is designed for development, training or demo purposes only. It is not intended for use in an industrial (manufacturing) environment.

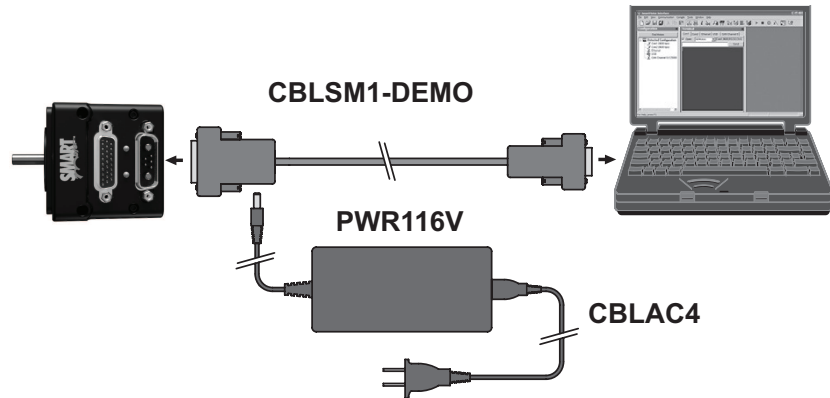

## RS-232 Through USB

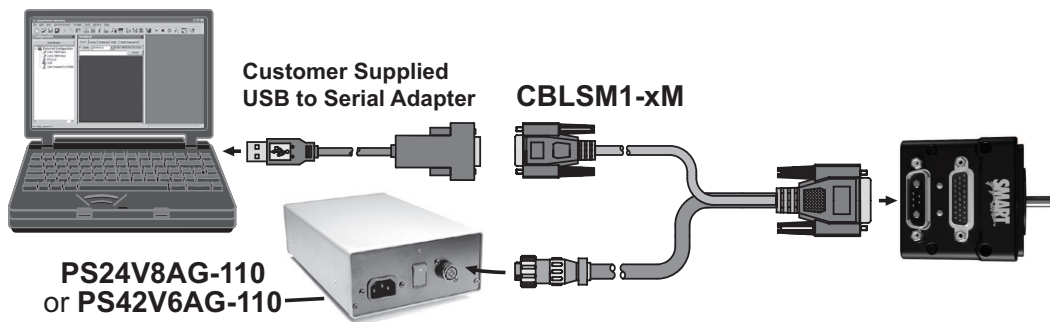

### Adding a USB to Serial Adapter

For this application, the customer must provide a USB to Serial (FTDI chipset) adapter, which is used on PCs that don't have a built-in serial port. The adapter allows you to connect from an available USB port on the PC to the serial interface on the SmartMotor. The adapter simply connects between the USB port and the serial cable, as shown in the previous figure. These adapters are readily available from computer supply stores and online shopping websites.

RS-232 with Protective Shunt

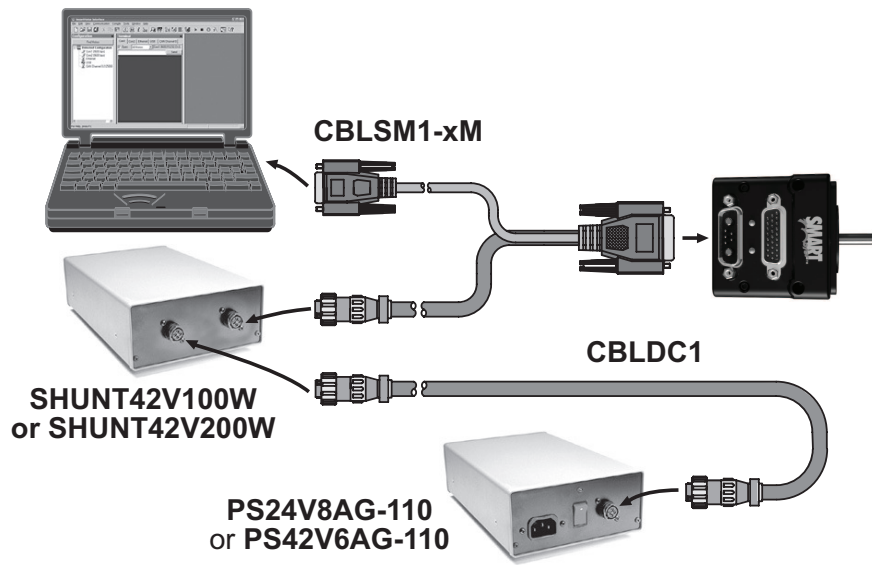

RS-232 Multidrop with Add-A-Motor Cables

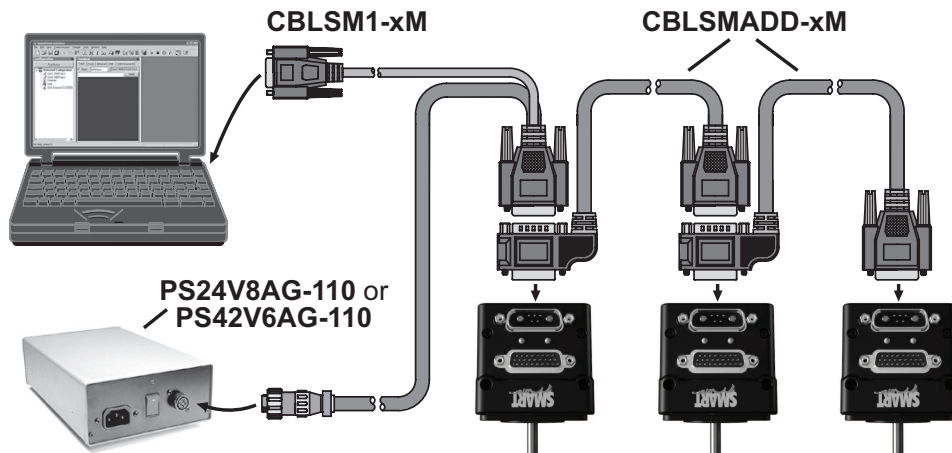

## USB to HD26 Connector

**NOTE:** The USB connection on CBLHD26-ASM is meant only for programming from the SMI software; it is not recommended for running the motor.

As shown in the pinout diagram (see page 35), the HD26 connector has pins available to support a USB connector attached to the end of a cable from those leads. When that is installed, a USB port on the host computer can be used to communicate directly with the SmartMotor without need for a USB to serial adapter. The SMI software provides direct support for that communication method. However, the USB connection is meant for programming only and is not recommended for running the motor.

The CBLHD26INT connector (see the next figure) incorporates a Micro USB port for direct connection of a customer-supplied USB cable along with a 120 ohm terminating resistor, in the form of a jumper located under the cover, that can be switched in/out as needed.

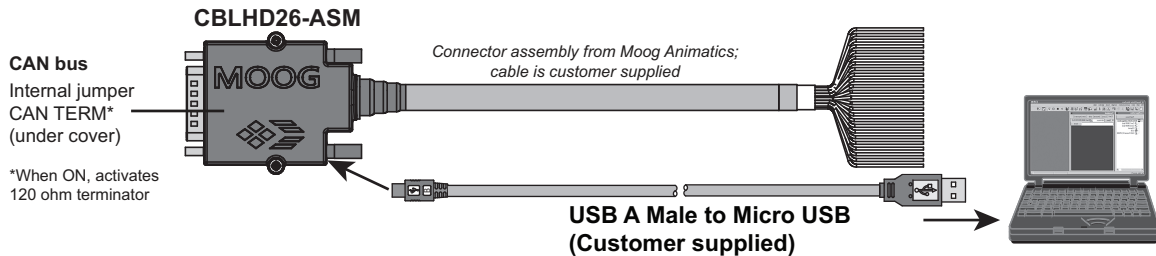

USB Connection to HD26 Cable

## Dual Power Configuration

The dual power configuration, a standard feature on the Class 6 D-style motor, allows the controller and drive amplifier to be powered from either a single or two separate DC power supplies. It is highly recommended to use the dual power configuration.

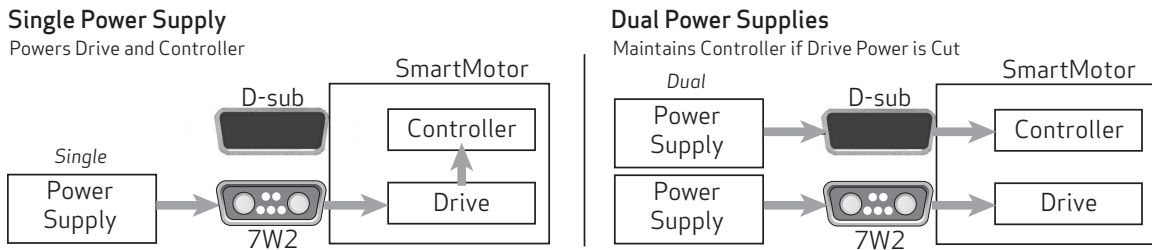

Single vs. Dual Power Configuration

**NOTE:** For the Class 6 D-style motor, if only one power supply connection is used, it must be through the Drive Power input, pins A1 and A2, on the 7W2 connector, which will also internally supply power to the motor's controller. User outputs will not operate, but inputs will operate. When separate power supplies are used, internal circuitry prevents their positive rails from shorting together.

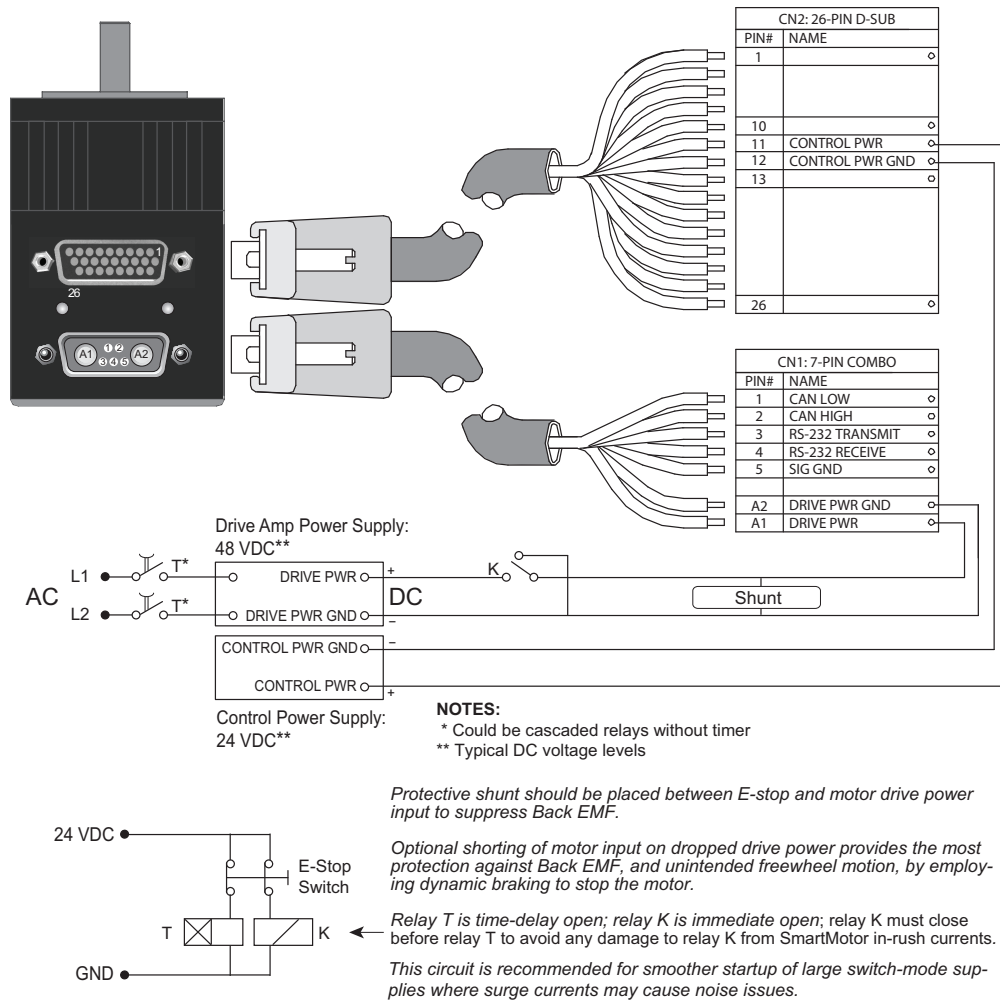

**NOTE:** All Class 6 D-style SmartMotors are designed to allow the use of separate drive and control power supplies. No special ordering option is needed for those SmartMotors.

## CDS Schematic

This section provides schematics for wiring a Class 6 D-style SmartMotor through the CDS CAN connection.

**NOTE:** CDS and CDS7 are included on all Class 6 D-style SmartMotor products.

### CDS on the HD26 Connector

As a standard feature, the Class 6 D-style SmartMotor provides a CDS CAN connection allowing CAN bus network wiring through the HD26 connector (26-pin D-sub I/O connector shown in the next figure). This eliminates a CAN connector on the back of the motor, leaving it free for other purposes, like the dual-port Industrial Ethernet option. The D-style motor with the CDS CAN connection can be used as the terminating node. To enable this, a 120 ohm terminating resistor (shunt) must be placed across pins 17 and 18. For details, see the next figure.

**NOTE:** Terminating resistors (shunts) must always be used at both ends of a CAN bus network.

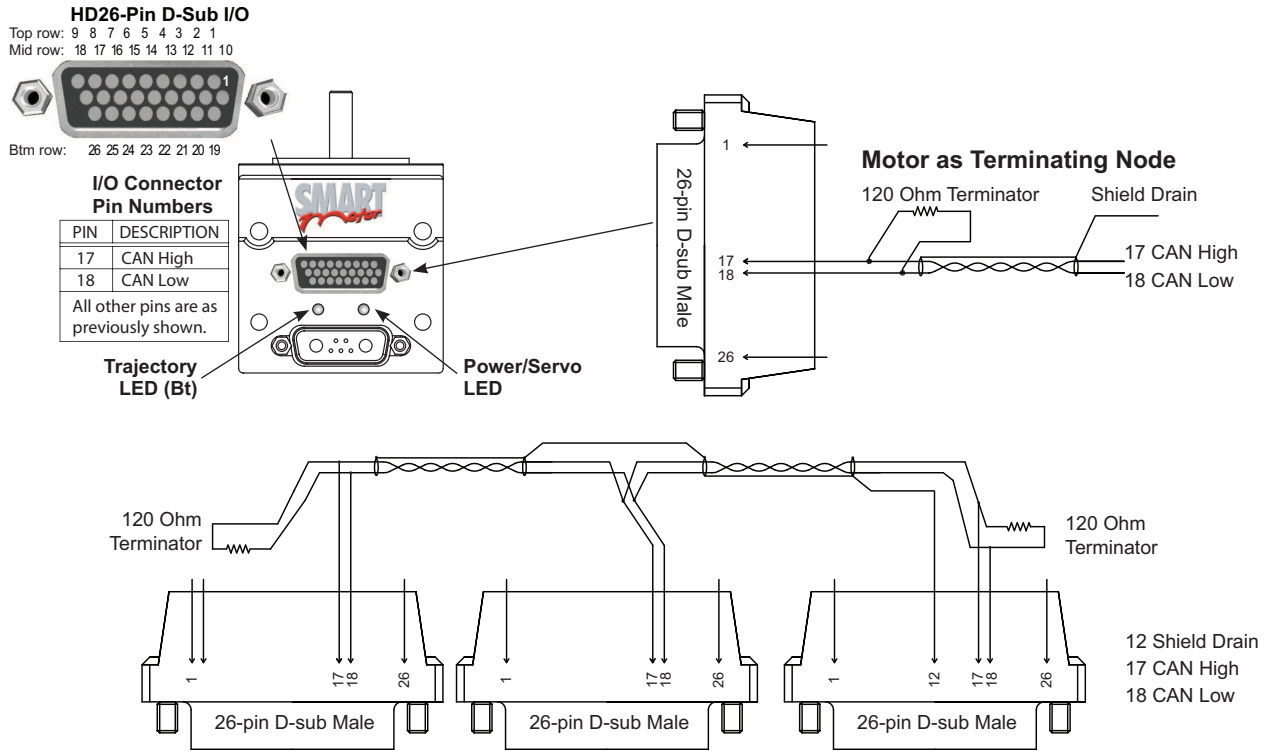

**NOTE:** A terminating resistor (shunt) or internal jumper on CBLHD26-ASM is required at each end of the bus. Bus must be multi-drop as shown, not a star network. 24V CAN bus power connection is not required at the motor.

*Schematic for CDS Option, D-Style SmartMotor Used as Terminating Node*

CDS on the 7W2 Connector (CDS7)



**CAUTION:**

If you are using the blue-overmolded Add-A-Motor cables (CBLSMCDS-xM) with CAN bus already in them:

1. Do not create a parallel path between the same motors on the 26-pin (HD26) D-sub connector, as that will cause impedance issues.
2. Any CAN nodes other than SmartMotors should be placed at the beginning and/or end of the SmartMotor chain using the 26-pin (HD26) D-sub connector. Do NOT "branch" to them from that connector in the middle of the SmartMotor chain. Branching is not allowed on the CAN bus.
3. Be aware of CAN signal wires being present or not in the incoming power/signal cable to the first 7W2 connector. If also using the 26-pin (HD26) D-sub connector to access the CAN signals, then this could form an unintended branch.

For more information on CAN best practices, visit CAN in Automation at [www.can-cia.org](http://www.can-cia.org).

Alternatively, CDS7 on the Class 6 D-style SmartMotor allows CDS to be wired through pins 1 and 2 of the 7-pin D-Sub (7W2) connector as shown in the next figure. The wiring is accomplished through the use of a single Add-A-Motor cable that carries Power, RS-232, and CAN bus to the next motor in the chain. This method allows pins 17 and 18 on the 26-pin D-sub connector to be used as an easy terminating point on the last motor by simply placing a 120 Ohm terminating resistor (shunt) across those pins.

This design not only greatly simplifies motor installation, but also does the same for CAN bus addressing. With CDS7, the SmartMotor is the first and only single-cable, point-to-point integrated motor to have both motor-to-motor full communications and control capability, and only single-cable, point-to-point for both power and communications in general.

As a result:

- When you order the Class 6 D-style SmartMotors and CDS7 Add-A-Motor cables, you get prewired, instant, full-network capability, and those networked motors are auto-detectable directly from SMI.
- This allows for auto-addressing and ease of reconnection at the next power up.
- Unlike competitive CANopen devices, the CDS7 SmartMotors do not require single-node power up to set addresses. You can power up all at once, have SMI detect them and set all motor CAN bus addresses in a single line of code. For details, see Detecting and Communicating with the SmartMotors on page 45.

CDS7 is fully backward compatible with the wiring method described in the previous section. Therefore, all Class 6 D-style SmartMotors can be wired either through the D-sub connector or the 7W2 connector.

When the SmartMotor is a terminating node on the CAN bus, the 120 Ohm terminating resistor (shunt) must be wired to pins 17 and 18 of the 26-pin D-sub connector, or use CBLHD26-ASM with internal jumper CAN TERM ON. A 120 Ohm terminating resistor (shunt) is also required at the beginning of the CAN bus. See the next figures.

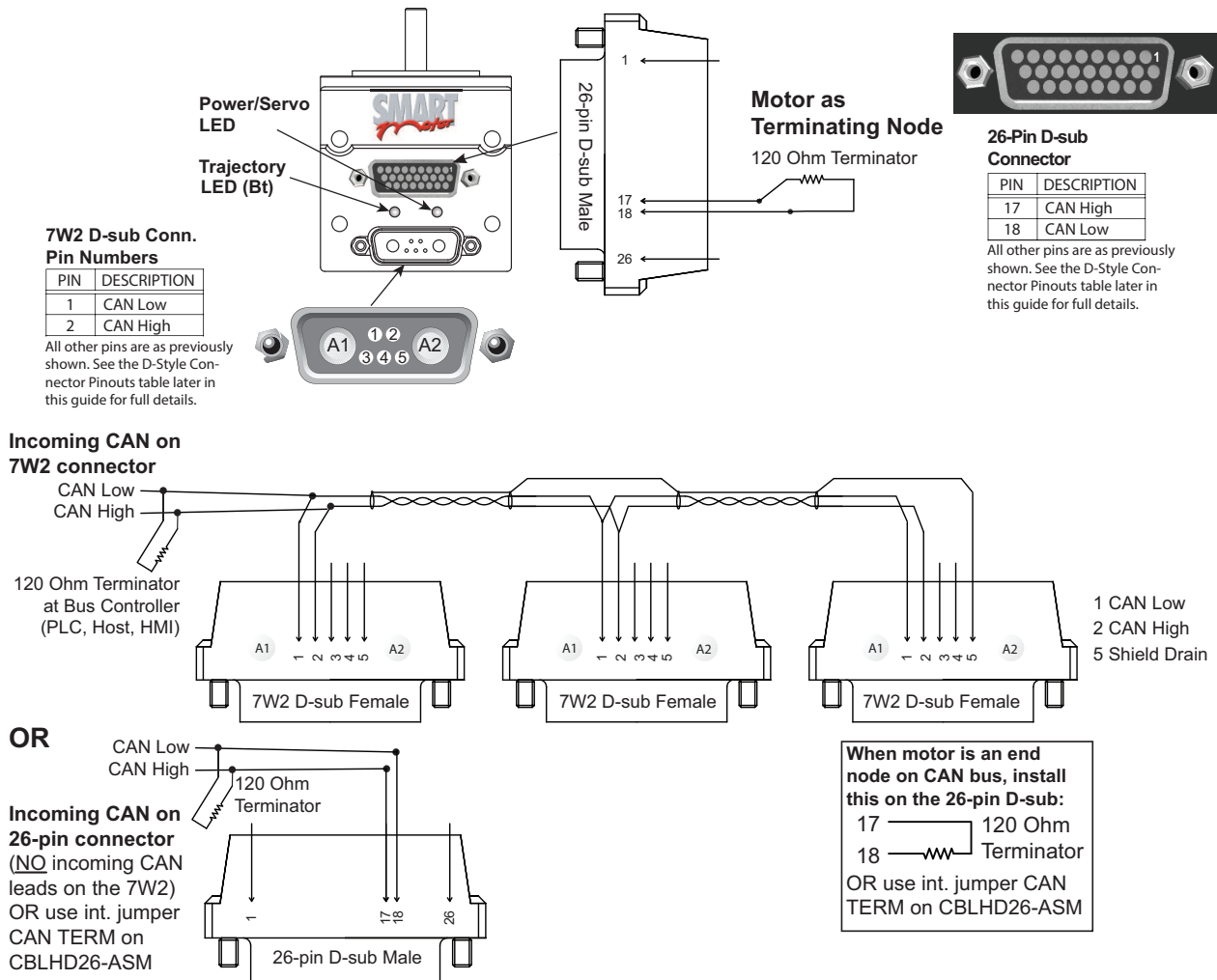

**NOTE:** A terminating resistor (shunt) or internal jumper on CBLHD26-ASM is required at each end of the bus. Bus must be multi-drop as shown, not a star network. 24V CAN bus power connection is not required at the motor.

*Schematic for CDS7 Option, D-Style SmartMotor Used as Terminating Node*

For the above methods, the incoming CAN bus signal is connected to the 7W2 connector OR the 26-pin connector, and the CDS Add-A-Motor cable (PN: CBLSMCDS-xM) will automatically provide CAN bus, RS-232 and power wiring in one cable between motors.

The next figure shows how factory cables are used to attach the incoming power and RS-232 communications to the 7W2 connector, and incoming CAN bus signal to the 7W2 connector OR the 26-pin connector (each method requires different cables).

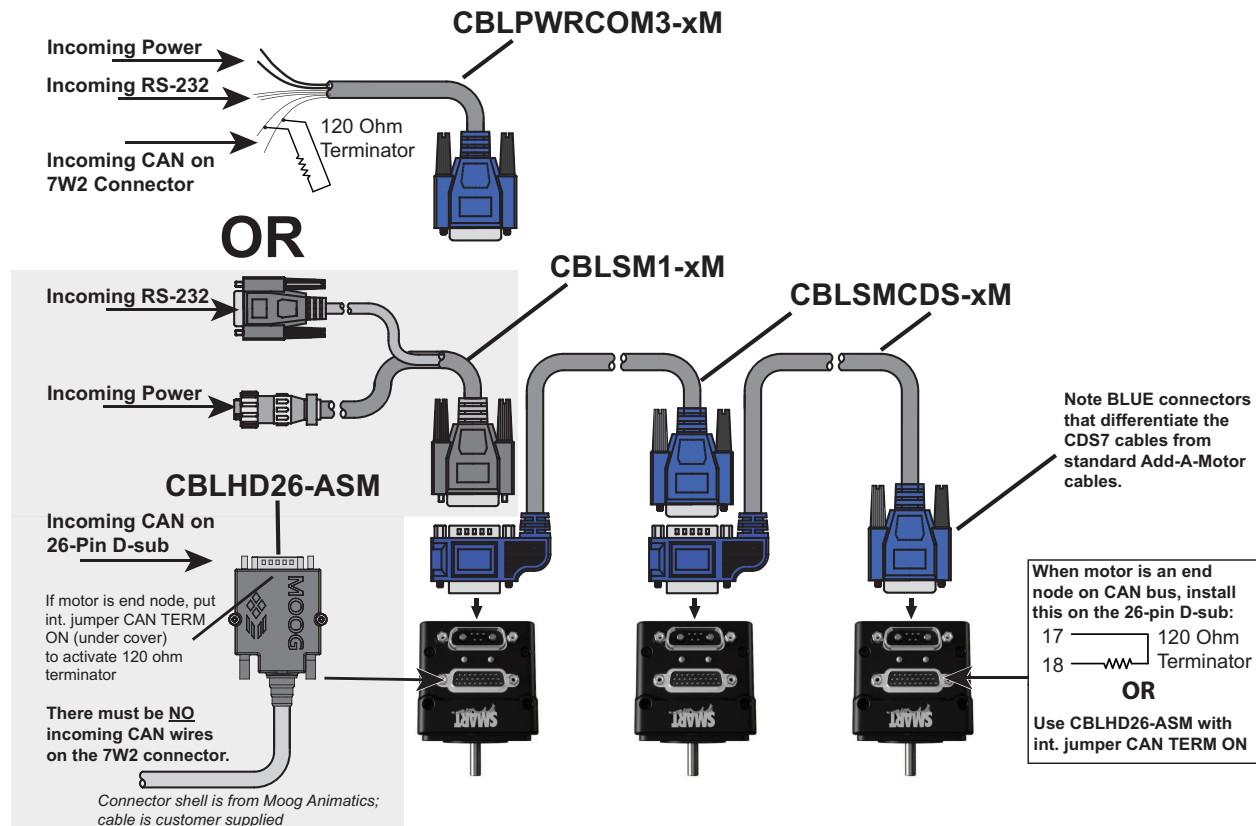

**NOTE:** A terminating resistor (shunt) or internal jumper on CBLHD26-ASM is required at each end of the bus. Bus must be multi-drop as shown, not a star network. 24V CAN bus power connection is not required at the motor.

*CDS7 Option Cabling Diagram*

Refer to these tables for part numbers and cable lengths:

CDS7 Cable PN	Length (Meters)	Power/Com Cable PN	Length (Meters)
CBLSMCDS-0.3M	0.3	CBLPWRCOM3-xM*	5, 10
CBLSMCDS-0.9M	0.9	CBLSM1-xM**	3, 10
CBLSMCDS-3.0M	3.0	CBLHD26-ASM**	

CDS7 Cable PN	Length (Meters)	Power/Com Cable PN	Length (Meters)
<b>CAUTION:</b> As noted by the BLUE connectors, these are NOT the same as the Add-A-Motor cables shown on page 37, and they are NOT interchangeable.		*Recommended method **Optional method	

See the cable data on the website or consult the factory for the schematic diagrams.

For PN: CBLHD26-ASM, see Class 6 D-Style HD26 Cable Connector (PN: CBLHD26-ASM).

### Industrial Ethernet Network

**NOTE:** If you have set your PC's network adapter to a fixed IP address for temporary connections to SmartMotors with SMI, remember to return it to DHCP when done to avoid local area network connectivity issues.

The Industrial Ethernet network is used for the EtherCAT (-EEC), EtherNet/IP (-EIP) and PROFINET (-EPN) options. Most Industrial Ethernet (IE) networks support line, tree or star device-connection topology. Tree or star network may require switches/hubs designed for that network type. Requirements for specific configurations depend on the capabilities of the controller device, the follower devices, and use of other networking equipment. For more details, refer to the corresponding SmartMotor fieldbus manual.



**CAUTION:** To minimize the possibility of electromagnetic interference (EMI), all connections should use *shielded* Ethernet Category 5 (Cat 5), or better, cables. All interconnecting cables in the daisy chain and/or ring configuration for Industrial Ethernet must have a length of at least 1 meter (3.28 feet).

The next diagram shows an example Industrial Ethernet network with the SmartMotors daisy chained to the controller device. A "ring" configuration can be created if the controller device has two ports.



**CAUTION:** When daisy-chaining SmartMotors for an EtherCAT network, you must connect the OUT port of the upstream motor to the IN port of the downstream motor. Refer to the Ethernet ports labeling on your SmartMotor.

## Industrial Ethernet Network

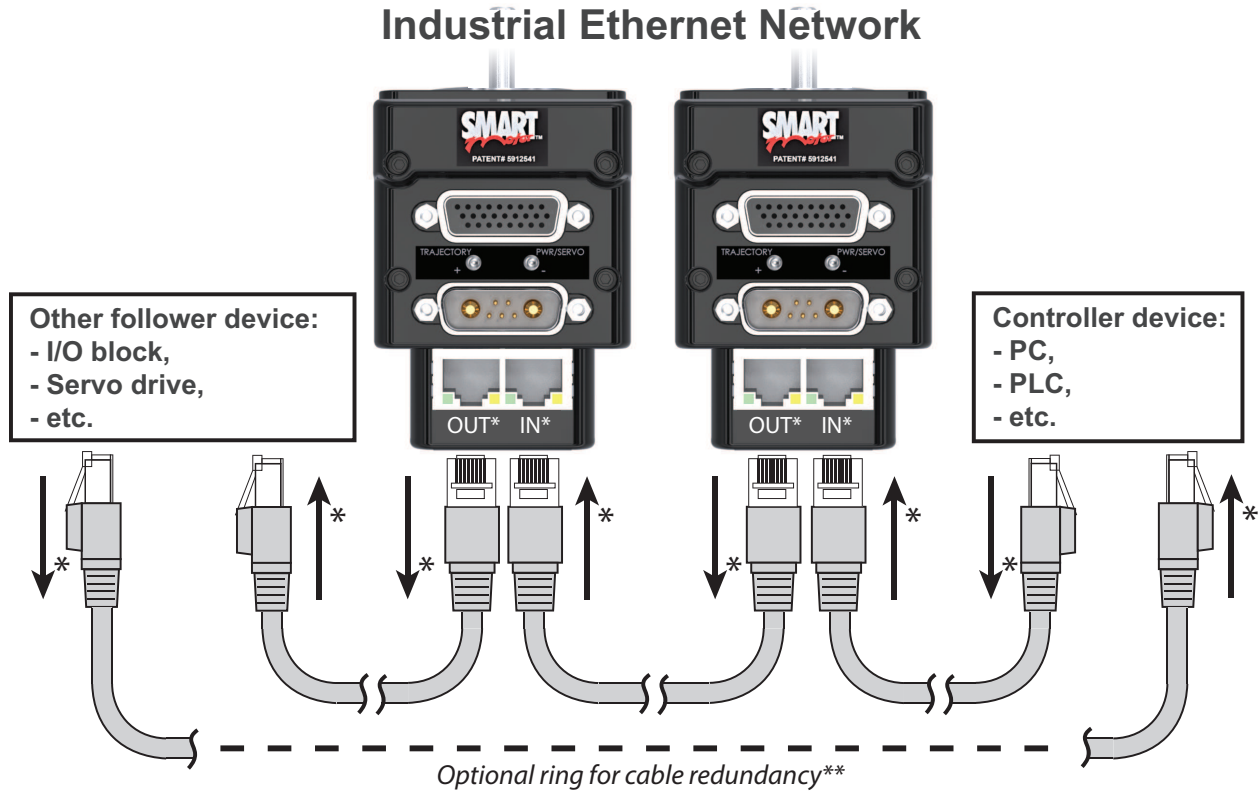

\*IN/OUT applies only to EtherCAT networks. Refer to the previous CAUTION and motor labeling.

\*\*Ring configuration requires a controller device with two ports

### Min and Max Cable Length

The minimum shielded Ethernet Cat 5 cable length between network nodes must be 1 meter.

For transmission speeds of 100 Megabits/second on shielded Ethernet Cat 5 cable, most Industrial Ethernet networks allow a maximum cable length up to 100 meters between network nodes.

### Ethernet Cables

For the Class 6 D-style SmartMotor with the Industrial Ethernet option, no special cables are required. That option adds a dual-port switch with 2 standard RJ45 connectors on the back of the motor. Those allow connection to your network, and also daisy chaining between motors using standard (not-crossover), off-the-shelf Cat 5 or better Ethernet cables, which are available from consumer electronics and computer supply stores.

**NOTE:** A crossover cable is not required. The Industrial Ethernet ports include an "auto-crossover" feature that will engage as needed.

## Understanding the Status LEDs

The section describes the functionality of the status LEDs on the Class 6 D-style SmartMotors.

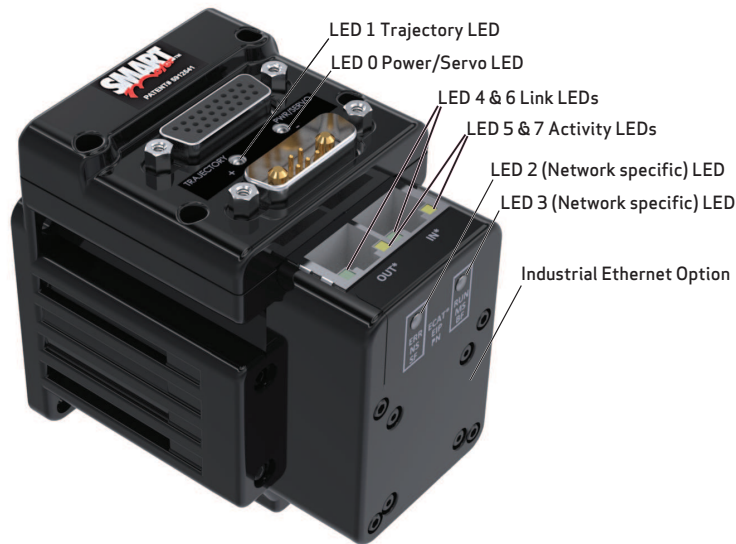

### LED 0: Power/Servo LED

Off	No power
Solid green	Drive on
Blinking green	Drive off, no faults
Triple red flash	Watchdog fault
Solid red	Faulted or no drive enable input
Alt. red/green	In boot load; needs firmware

### LED 0 and 1 Status on Power-up:

- With no program and the travel limit inputs are low:  
LED 0 solid red; motor in fault state due to travel limit fault  
LED 1 off
- With no program and the travel limits are high:  
LED 0 solid red for 500 milliseconds then flashing green  
LED 1 off
- With a program that only disables travel limits:  
LED 0 red for 500 milliseconds then flashing green  
LED 1 off

### LED 1: Trajectory LED

Off	Not busy
Solid green	Drive on, trajectory in progress
Flashing # red	Flashes fault code (see below) when Power/Servo LED is solid red

**Fault Codes:** pauses for 2 sec before flashing the code

### Flash Description

1	NOT Used
2	Bus Voltage
3	Over Current
4	Excessive Temperature
5	Excessive Position
6	Velocity Limit
7	dE/Dt - First derivative of position error is excessive
8	Hardware Positive Limit Reached
9	Hardware Negative Limit Reached
10	Software Positive Travel Limit Reached
11	Software Negative Travel Limit Reached

### LED 2: (Network specific) LED

Industrial Ethernet Option

Refer to the corresponding SmartMotor  
fieldbus guide

### LED 4 & 6 Link LEDs

Off	No/bad cable; no/bad Link port
Solid green	Link established

### LED 3: (Network specific) LED

Industrial Ethernet Option

Refer to the corresponding SmartMotor  
fieldbus guide

### LED 5 & 7 Activity LEDs

Off	No activity
Blinking amber	Activity

## Detecting and Communicating with the SmartMotors

**NOTE:** Depending on the SMI software version and SmartMotor model being used, the software version and motor information may be different on your screens.

This section describes how to detect and address the Class 6 SmartMotor.

This procedure assumes that:

- The SmartMotor is connected to the computer.
- The SmartMotor is connected to a power source.
- The SMI software has been installed and is running on the computer. For details, see *Installing the SMI Software* on page 26.

## Understanding the Detection and Configuration Options

**NOTE:** This feature requires connection to the serial (COM) port, configured as RS-232 or RS-485.

There are several ways to use the SMI software to find and address the Class 6 D-style SmartMotors that are connected to your PC:

- Use the Find Motors button—this method is recommended for first-time communications or when you don't know the port used to connect the motors. For details, see *Using the Find Motors Button* on page 46.
- Use the Detect Motors feature—this method can be used if you know the communications port used to connect your motors and if your motors may be pre-addressed. For details, see *Using the Detect Motors Feature* on page 49.

Several of these methods are described in the next sections.

### Using the Find Motors Button

The easiest way to locate any connected SmartMotor is to use the Find Motors button (see the next figure). This method searches all ports on the PC for connected motors.

To begin searching for motors on the PC, in the Configuration window of the SMI software interface, click Find Motors. The SMI software begins searching for all SmartMotors connected to the PC.

**NOTE:** The next figures show examples for an RS-232 SmartMotor. To see similar example figures for USB motors, refer to *Using the Detect Motors Feature* on page 49.

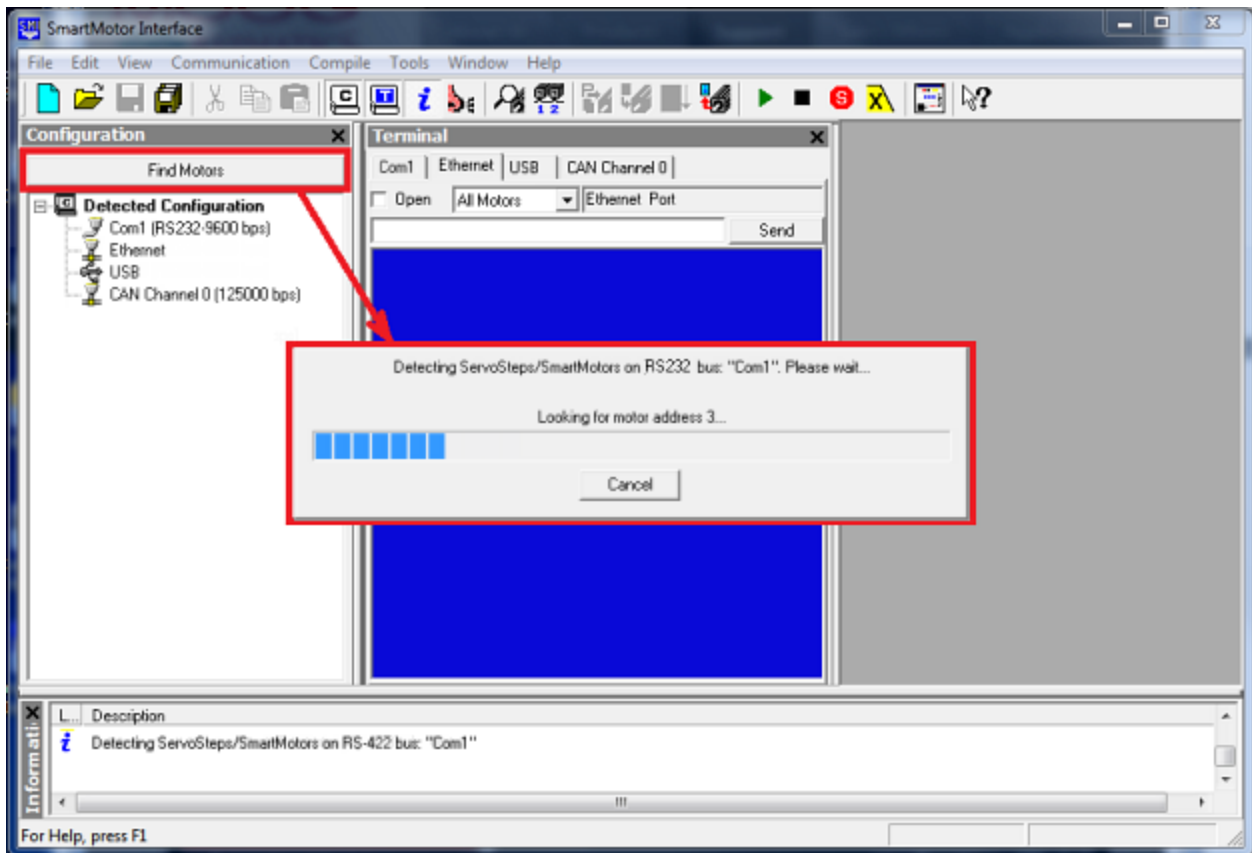

*Find Motors Detecting SmartMotors on the RS-232 Chain*

After the process has completed, the SMI software shows the found motors in the Configuration window under the corresponding communications port. Each motor is represented by a motor icon; the motor's address and firmware version are shown next to the motor icon.

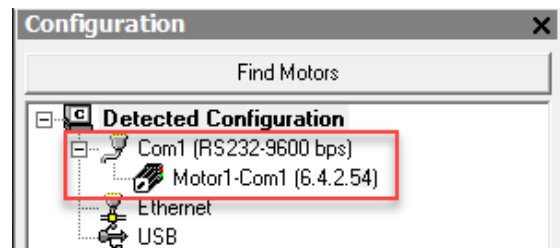

*Configuration Window Showing Found/Detected RS-232 SmartMotor*

To address the motor, right-click on the motor and select Set Motor Address. For more details, see the *SMI Software Help*, which can be accessed within SMI by pressing F1 or from the Help menu.

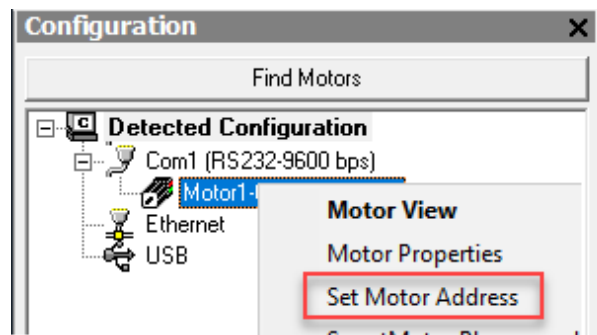

Motor Menu - Set Motor Address

The motor's detailed information can be viewed in the Motor View window, which is accessed by selecting the **Tools > Motor View > Info** tab.

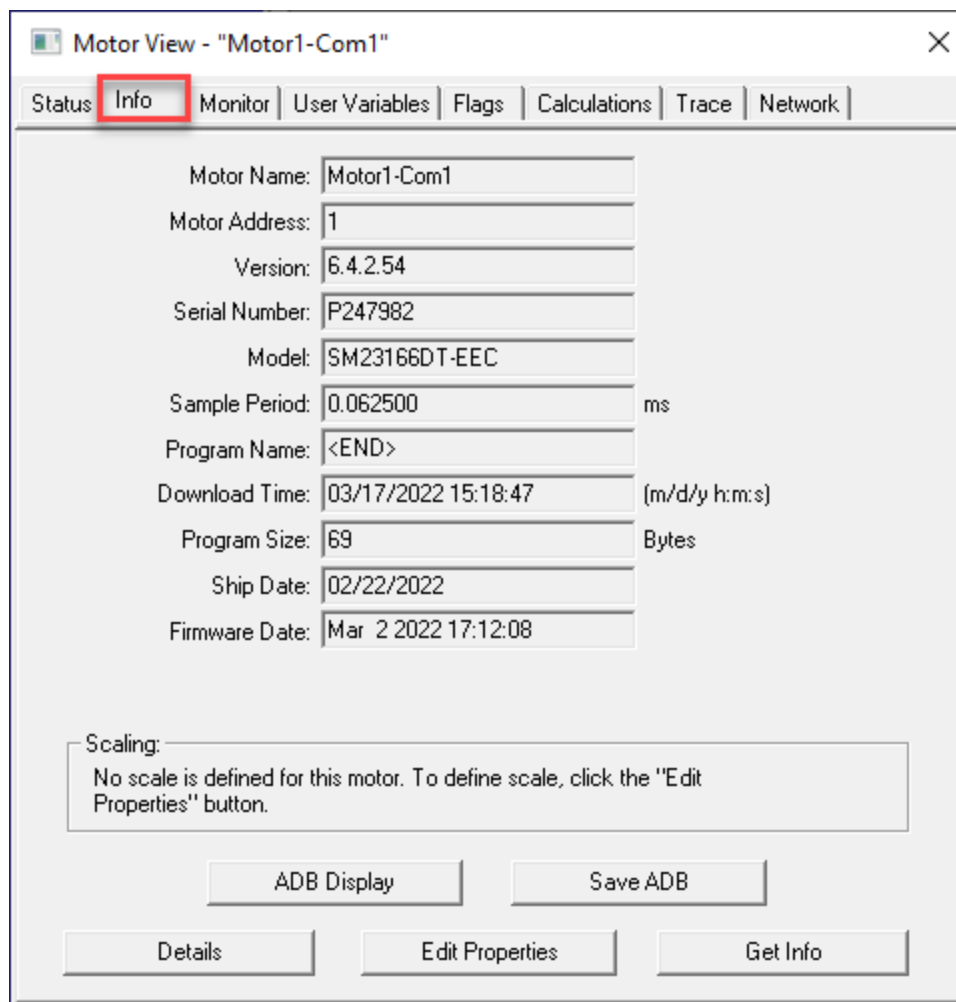

Motor View Information Tab

## Using the Detect Motors Feature

This method is similar to the Find Motors method, but it searches only the specified communications port for connected SmartMotors. This is also the recommended method for detecting Class 6 D-style motors after they have been pre-addressed and daisy-chained to the communications port.

To use the Detect Motors feature, in the Configuration window of the SMI software, right-click the desired communications port and select Detect Motors from the menu.

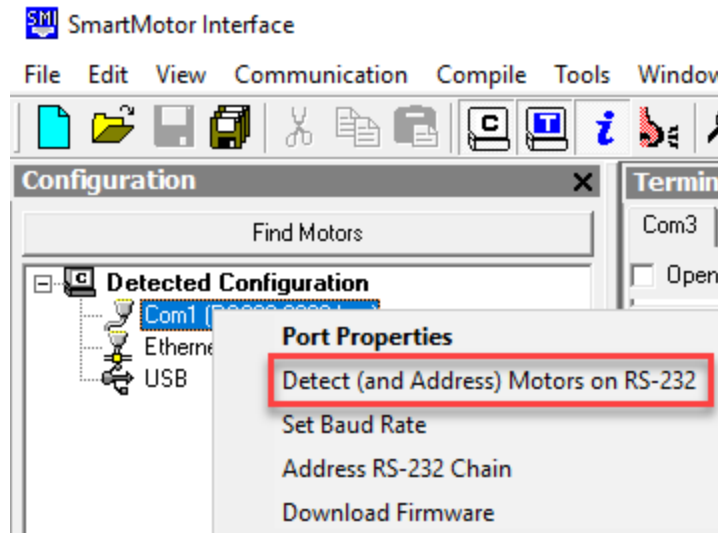

*Selecting the Detect Motors Feature*

The SMI software begins searching for all SmartMotors connected to the specified communications port. A progress bar is shown while the SMI software searches for the motors.

After the process has completed, the SMI software shows the found motors in the Configuration window under the corresponding communications port. Each motor is represented by a motor icon; the motor's address and firmware version are shown next to the motor icon.

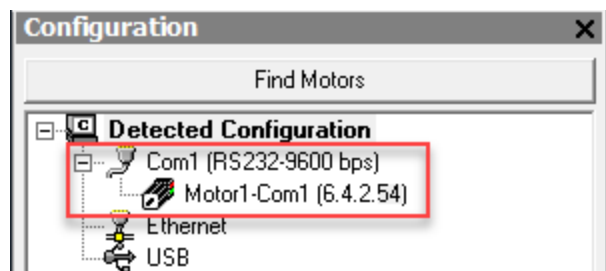

*Configuration Window Showing Found/Detected SmartMotor*

To address the motor, right-click on the motor and select Set Motor Address. For more details, see the *SMI Software Help*, which can be accessed within SMI by pressing F1 or from the Help menu.

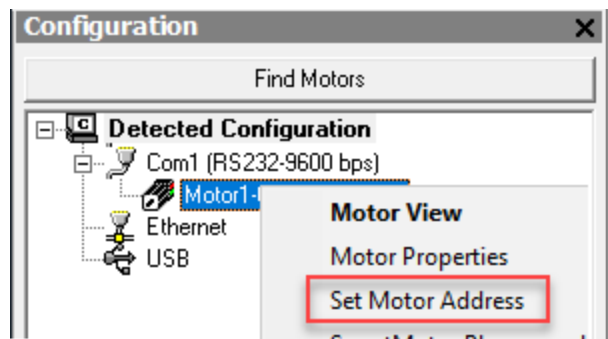

Motor Menu - Set Motor Address

The motor's detailed information can be viewed in the Motor View window, which is accessed by selecting the **Tools > Motor View > Info** tab.

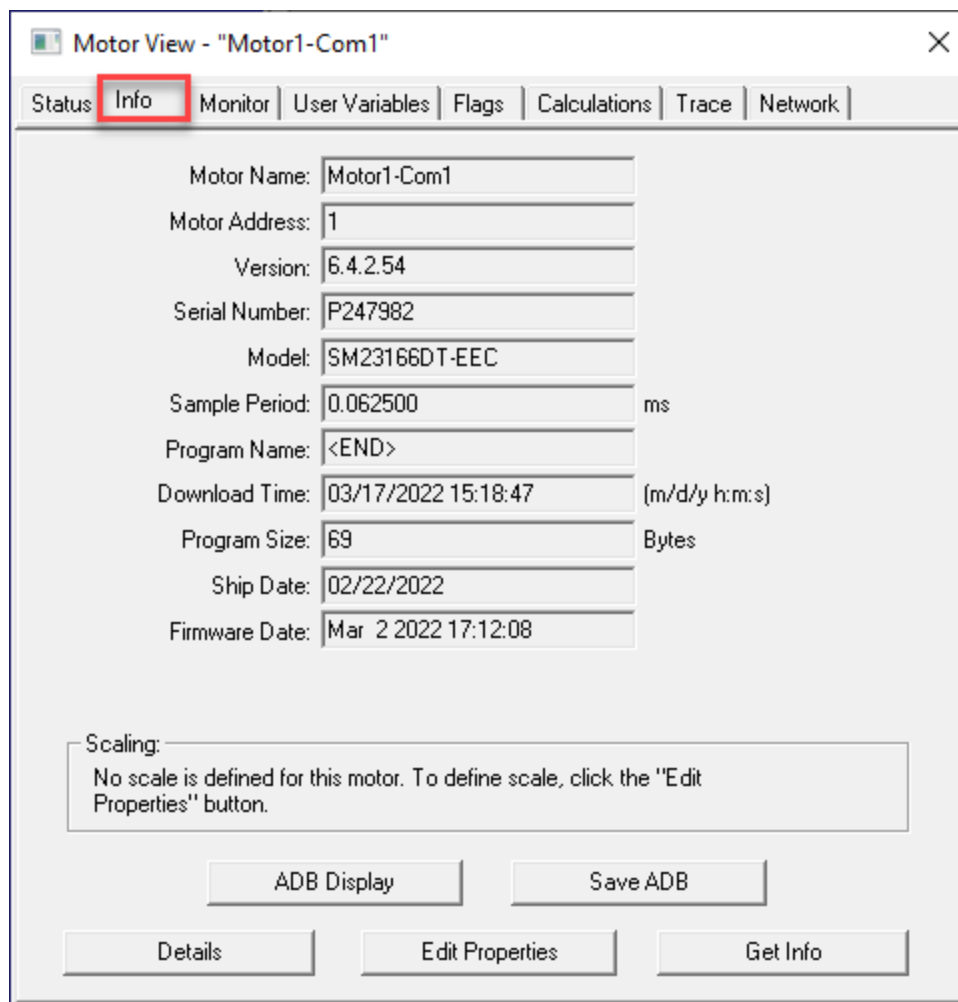

Motor View Information

## Checking and Clearing the Status Bits

**NOTE:** In addition to the software information in this section, there is context-sensitive help available within the SMI software interface, which is accessed by pressing the F1 key or selecting Help from the SMI software main menu.

The Motor View window is used to view and monitor various motor parameters. It is used in conjunction with the Terminal window to clear any active overtravel limits.

This procedure assumes that:

- The SmartMotor is connected to the computer.
- The SmartMotor is connected to a power source.
- The SMI software has been installed and is running on the computer. For details, see *Installing the SMI Software* on page 26.
- The SmartMotor has been detected and addressed.

## Polling the Motor

To view the current state of the status bits, you must poll the motor.

1. Double-click the motor icon to open the Motor View window (see the next figure).
2. Click the Poll button to begin polling data from the motor.

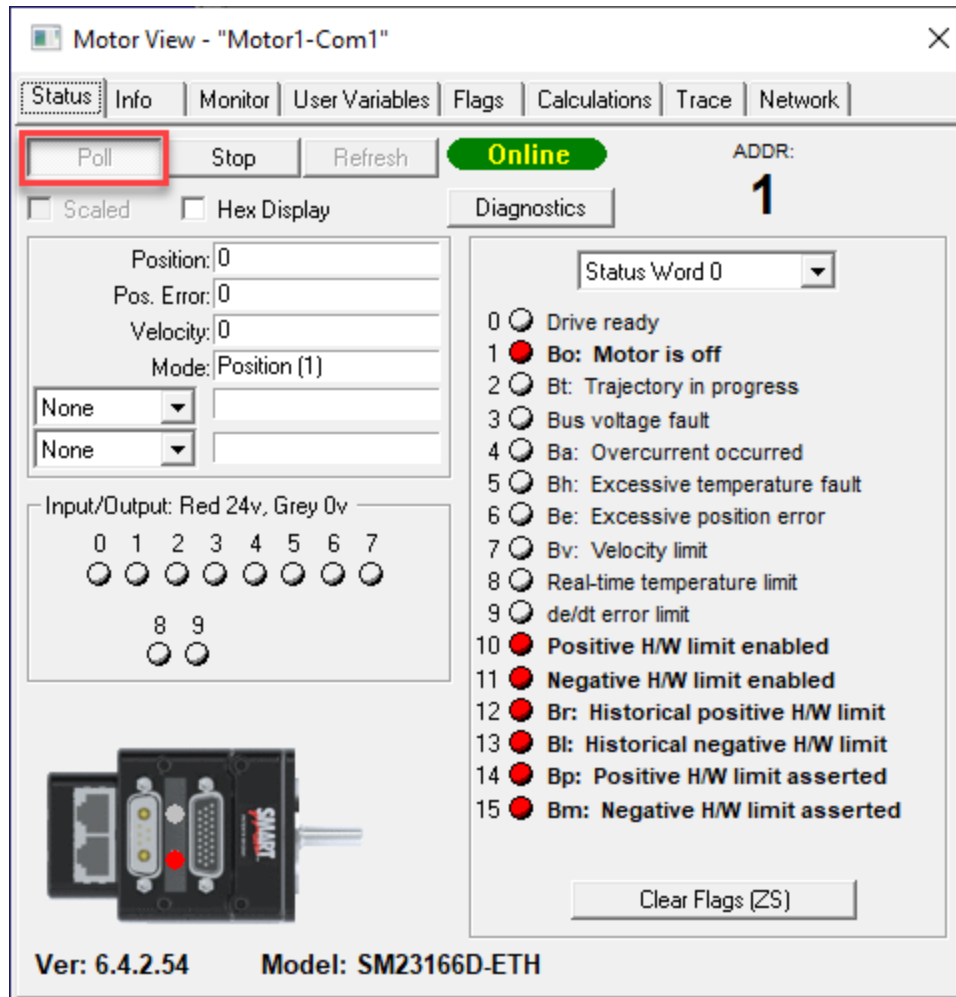

*Motor View*

A SmartMotor with no program and no I/O connections will boot up with active overtravel limits (see the red status bits numbered 10 through 15 in the previous figure).

## Clearing the Overtravel Limits and Fault Bits

To disable (clear) the overtravel limits, enter EIGN(2) and EIGN(3) in the SMI software Terminal window. This sets I/O 2 (positive overtravel limit) and I/O 3 (negative overtravel limit) as general inputs/outputs instead of being used as travel limits. To set all status bits in Word 0 as general inputs/outputs, enter EIGN(W,0).

**NOTE:** You can either type the command in the white text box or type the command directly in the blue area of the terminal screen and then click Send or press Enter.

The active and asserted bits are cleared, as shown in the next figures.

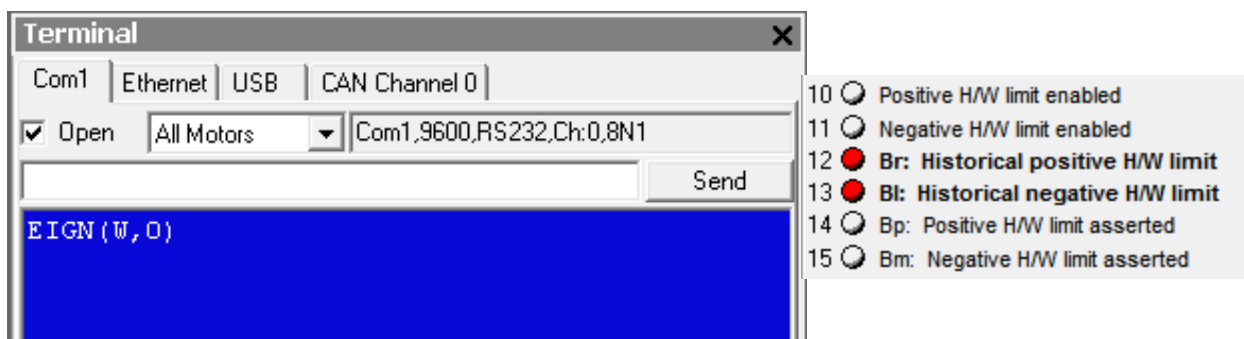

*EIGN Command Entered*

*Active and Asserted Bits Cleared*

To clear the historical fault bits, enter ZS. All remaining fault bits are cleared, as shown in the next figures.

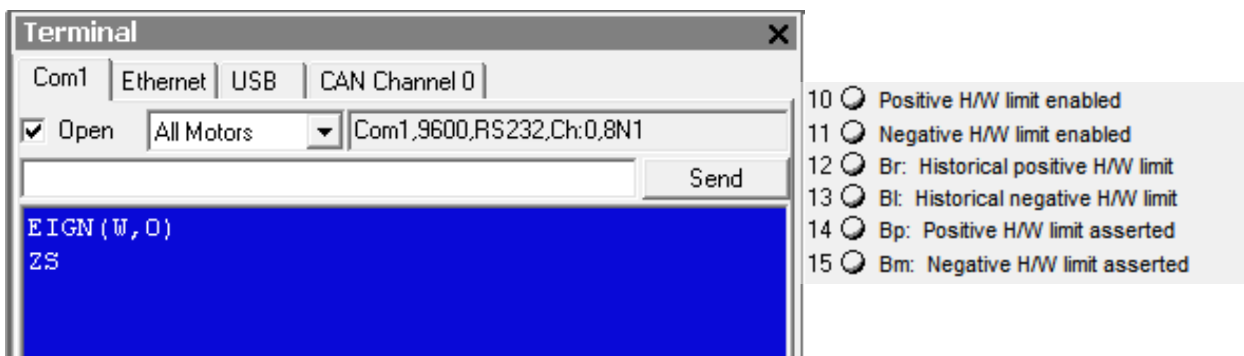

*ZS Command Entered*

*Remaining Bits Cleared*

## Moving the SmartMotor

**NOTE:** In addition to the software information in this section, there is context-sensitive help available within the SMI software interface, which is accessed by pressing the F1 key or selecting Help from the SMI software main menu.

The SMI software contains a Torque mode that is used to test the motor response and ensure the drive is operating properly.

This procedure assumes that:

- The SmartMotor is connected to the computer.
- The SmartMotor is connected to a power source.
- The SMI software has been installed and is running on the computer. For details, see Installing the SMI Software on page 26.
- The SmartMotor has been detected and addressed.
- The fault bits have been cleared. For details, see Checking and Clearing the Status Bits on page 51.

## Making the Motor Move



**WARNING:** The larger SmartMotors can shake, move quickly and exert great force. Therefore, proper motor restraints must be used, and safety precautions must be considered in the workcell design (see Other Safety Considerations on page 9).

To make the SmartMotor move:

1. In the Terminal window, select the tab that matches the communications channel to which your motors are connected. To do this, look at the Configuration window, find the channel where the motors are listed and click that tab name in the Terminal window.

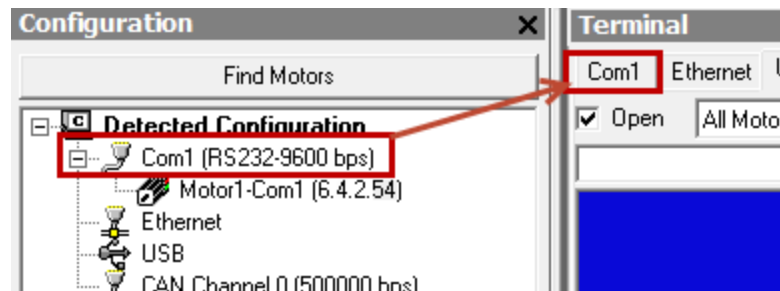

*Tab Selected that Matches the Communications Channel*

**NOTE:** If you do not have the correct tab selected, the commands you enter will not go to the motors and there will be no response.

2. Enter these commands in the Terminal window:

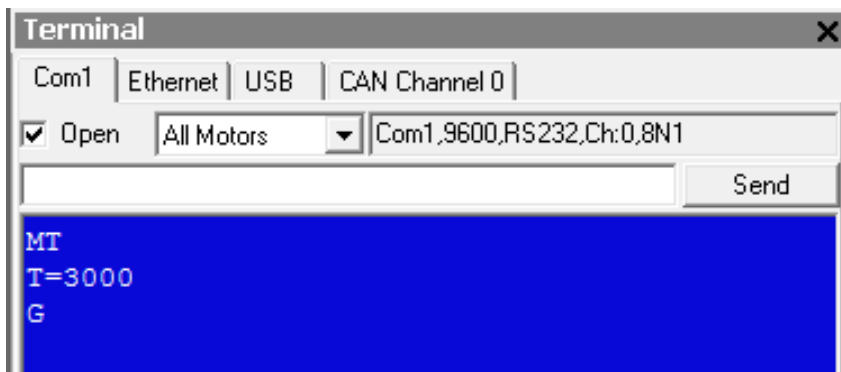

You should immediately see the motor shaft moving in the positive direction (clockwise, when looking at the end of the motor shaft). If the motor does not respond to the commands, see Troubleshooting on page 69 for troubleshooting tips.

**NOTE:** Macros (shortcut keys) can be used to simplify entry of frequently-used commands. For details, see Macros in the *SmartMotor™ Developer's Guide*.

3. After you have observed the motor shaft turning, enter the X command to decelerate the motor to a stop.

## Setting and Reporting Torque

The commands in this section are related to the previous motion procedure. For more details on these commands, see the *SmartMotor™ Developer's Guide*.

### MT (Mode Torque)

MT sets the mode of operation to torque mode. In this mode, the SmartMotor shaft applies a torque independent of position. For more details, see Torque Mode in the *SmartMotor™ Developer's Guide*.

### T=formula (Set Target Torque)

T can be set to any value from -32767 to +32767, which represents -99.99% to +99.99% PWM (pulse-width modulation) commanded.

### RTRQ (Report Actual Torque)

Enter RTRQ at the Terminal window to report the commanded torque from the trajectory generator.

Note that RTRQ typically reports a value that's one less than the T value. In the previous example, T=3000, but RTRQ reports 2999. The value returned by TRQ (and RTRQ) will typically be one less than the T (torque) value due to internal calculations. It may also be reduced in cases where the motor's output is in limitation. TRQ represents the output effort of the motor in both MT (torque mode) and servo modes (MV, MP, etc.). Therefore, it provides a seamless transfer across those modes without causing a ripple or bump in force to the load.

### TS (Set Torque Slope)

The TS command defines how fast the processor applies a change in torque. For an example of the TS command, see the Chart View Example in the *SmartMotor™ Developer's Guide*.

Torque slope can range from -1 to 2147483647 (default). At a value of 65536, the processor changes torque by a value of 1 for each PID sample. The default sample rate is 16000; you can view the current sample rate with the RSAMP command.

**NOTE:** If you're moving from a Class 5 to a Class 6 SmartMotor, the faster Class 6 sample rate means the torque slope operates twice as fast in real-world time.

## Checking the Motor Position

There are several ways to check the motor position:

- Report the position using commands from the Terminal window
- View the position in the Motor View tool

These two methods are described in the next sections. You can also view the position in the Monitor or Chart View software tools. For details, see SMI Software Features in the *SmartMotor™ Developer's Guide*.

This procedure assumes that:

- The SmartMotor is connected to the computer.
- The SmartMotor is connected to a power source.
- The SMI software has been installed and is running on the computer. For details, see Installing the SMI Software on page 26.
- The SmartMotor has been detected and addressed.
- The fault bits have been cleared. For details, see Checking and Clearing the Status Bits on page 51.

### Viewing the Motor Position with a Report Command

To report the motor position, in the Terminal window, issue the RPA (Report Position Actual) command:

```
RPA
```

The terminal responds with the current position of the motor:

```
RPA      3593657
```

**NOTE:** The position is reported on the same line as the command; there is no line feed or carriage return for "report" commands.

The RPA command reports the actual motor position at the time the command was issued. Therefore, it is just a "snapshot"—if the motor is moving, the reported position is not dynamically updated.

### Viewing the Motor Position with the Motor View Tool

The Motor View tool provides another way to view the motor position. The advantage of using this tool is that the position is dynamically updated when the motor is moving.

To open the Motor View tool, from the SMI software Configuration window, right-click the motor you want to view and select Motor View from the menu.

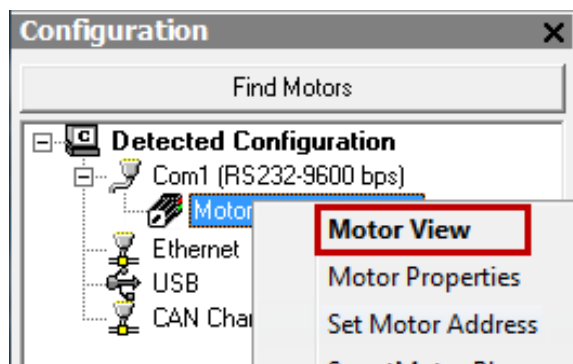

Opening the Motor View Tool

After the Motor View window opens, click the Poll button to begin polling (getting information from) the motor. After polling begins, the motor position is shown in the Position box.

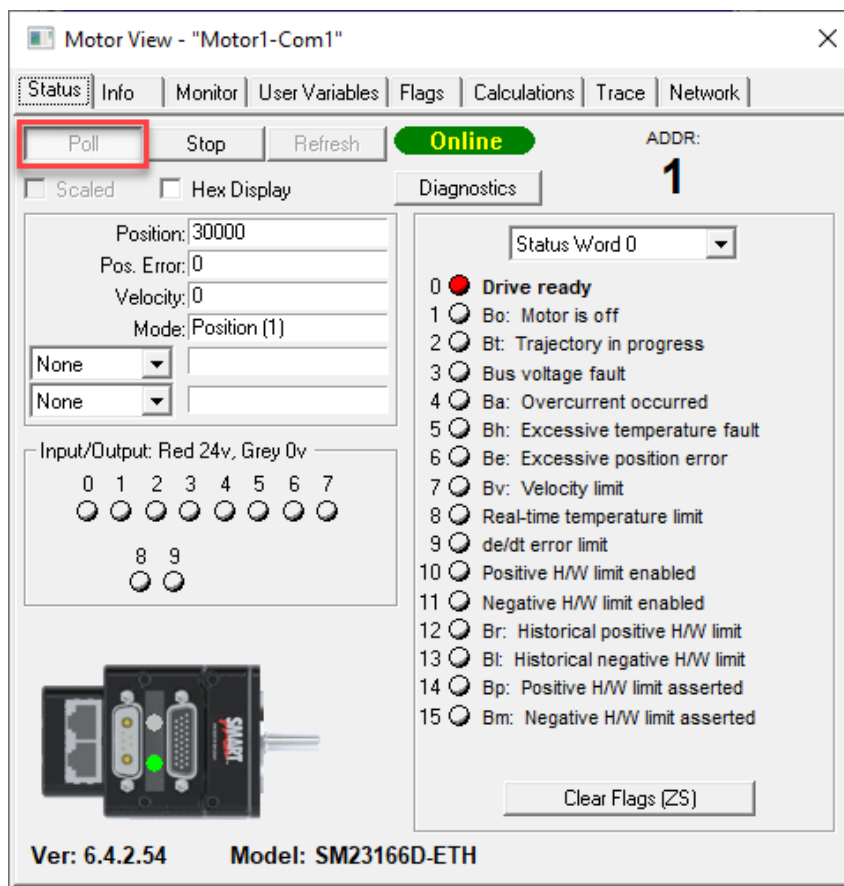

Motor View Tool Showing the Motor Position

## Connectors, Pinouts and Examples

This chapter provides information on the SmartMotor connector pinouts and specifications. It also provides example I/O connection diagrams. For information on connecting the motors, see .

<b>Class 6 D-Style Connector Pinouts</b> .....	<b>59</b>
<b>Class 6 D-Style I/O Connection Examples</b> .....	<b>60</b>
<b>Class 6 D-Style HD26 Cable Connector (PN: CBLHD26-ASM)</b> .....	<b>62</b>

## Class 6 D-Style Connector Pinouts

This table shows the pinouts for the connectors on the Class 6 D-style SmartMotors.

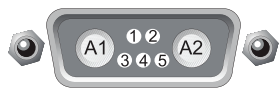
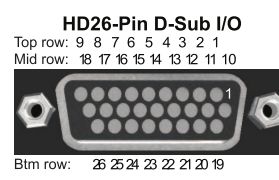
Pin	7W2 Connector (Main Power)	Specifications:	Notes:	P1
1	CAN Low (also on HD26)	1 Mbit/sec Max	Redundant to HD26 connector	
2	CAN High (also on HD26)			
3	RS-232 Transmit (COM CH 0)	115.2 Kbaud Max		
4	RS-232 Receive (COM CH 0)			
5	SIG Ground			
A1	Main Power	+24-48 VDC	See NOTE	
A2	Common Ground (req'd. POWER Ground)		Must be Main Power Ground	
Pin	HD26 Connector (24 V Sourcing I/O)	Specifications:	Notes:	P2
1	IN0 GP, also Analog Input		<b>For Inputs:</b> 9 Configurable and 1 Dedicated Low Lvl Thld: 3.6 V Max High Lvl Thld: 6.0 V Min Analog Input Scale: 10 V FS Inp Impedance >10 Kohm	
2	IN1 GP, also Analog Input			
3	IN2 Positive Limit or GP			
4	IN3 Negative Limit or GP			
5	IN/OUT4 GP or Ext. Enc. Index Capture			
6	IN/OUT5 GP or Int. Enc. Index Capture			
7	IN6 GP, G Command or Homing Input			
8	IN7 Drive Enable Input (Dedicated)		<b>For Outputs:</b> Do not exceed 200 mAmps source each or 400 mAmps combined	
9	IN/OUT8 GP or Brake Line Output			
10	IN/OUT9 GP or Not Fault Output		Also supplies I/O; do not exceed 32 V max Nonisolated	
11	+24 VDC Control Power	+24 V Logic I/O, range 18 - 32 V max Ground Reference		
12	Control Power Return (Ground, Common)			
13	Encoder A+ Input			
14	Encoder A- Input	1.5 MHz max as Enc or Step input		
15	Encoder B+ Input			
16	Encoder B- Input			
17	CAN High (also on 7W2)	1 Mbit/sec Max	Redundant to 7W2 connector	
18	CAN Low (also on 7W2)			
19	RS-485 B (COM CH 1)	115.2 Kbaud Max		
20	RS-485 A (COM CH 1)			
21	nc.			
22	nc.			
23	USB +5 V Bus		For programming from SMI, not recommended for running the motor	
24	USB D+			
25	USB D-			
26	Ground, Common			

**NOTE:** These motors can operate on power down to +20 VDC, but it is not recommended due to greatly reduced performance—optimum performance is achieved at 48VDC.

**NOTE:** Optional dual-port Ethernet connectors (not shown above) are industry standard RJ 45 and compatible with off-the-shelf Cat 5 or better cables available at any consumer electronics or computer supply store.

**NOTE:** All specifications are subject to change without notice. Consult the factory for the latest information.

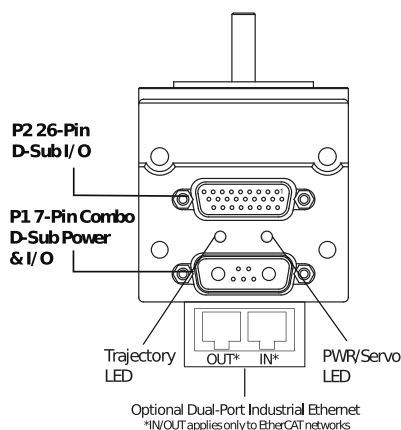

**CAUTION:** DO NOT exceed the specified voltage limits, as this may cause immediate damage to the internal electronics, which will void the warranty.

**CAUTION:** Pins 11 and 12 are intended as an input for control/ IO power only. DO NOT attempt to use those pins for main servo-drive power, as this may result in immediate damage to the electronics, which will void the warranty.

## Class 6 D-Style I/O Connection Examples

This section shows I/O connection examples for the Class 6 D-style motors. Also, refer to Class 6 D-Style Connector Pinouts on page 59 for connector specifications.

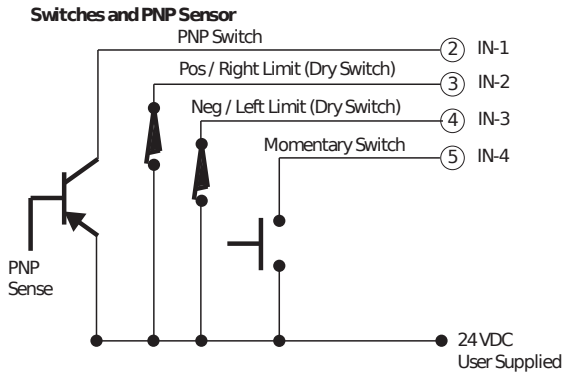

**NOTE:** I/O is Sourcing type (PNP)

PIN	DESCRIPTION
1	IN0 GP, also Analog Input
2	IN1 GP, also Analog Input
3	IN2 Positive Limit or GP
4	IN3 Negative Limit or GP
5	IN/OUT4 GP or Ext. Enc. Index Capture
6	IN/OUT5 GP or Int. Enc. Index Capture
7	IN6, G cmd or Homing Input
8	IN7, Drive Enable Input (Dedicated)
9	IN/OUT8, GP or Brake Line Output
10	IN/OUT9, GP or Not Fault Output
11	+24 VDC Control Power
12	Control Power Rtn (Ground, Common)
13	Encoder A+ Input

PIN	DESCRIPTION
14	Encoder A- input
15	Encoder B+ input
16	Encoder B- input
17	CAN High (also on 7W2)
18	CAN Low (also on 7W2)
19	RS-485 B (COM CH 1)
20	RS-485 A (COM CH 1)
21	n.c.
22	n.c.
23	USB +5 V Bus
24	USB D+
25	USB D-
26	Ground, Common

### HD26-Pin D-Sub I/O

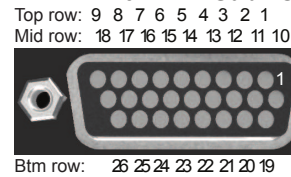

### Class 6 D-Style Analog Pot and Sensor

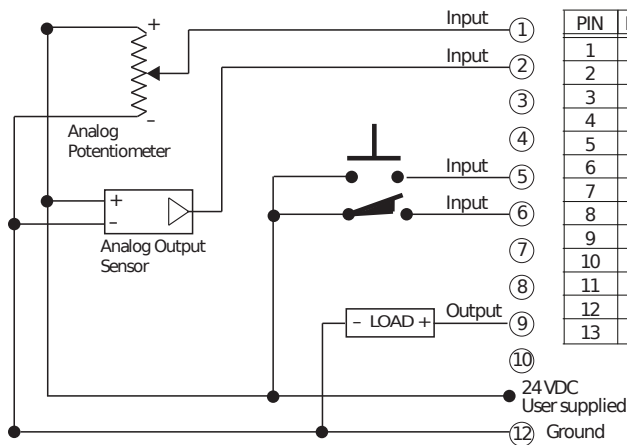

**NOTE:** I/O is Sourcing type (PNP)

PIN	DESCRIPTION
1	IN0 GP, also Analog Input
2	IN1 GP, also Analog Input
3	IN2 Positive Limit or GP
4	IN3 Negative Limit or GP
5	IN/OUT4 GP or Ext. Enc. Index Capture
6	IN/OUT5 GP or Int. Enc. Index Capture
7	IN6, G cmd or Homing Input
8	IN7, Drive Enable Input (Dedicated)
9	IN/OUT8, GP or Brake Line Output
10	IN/OUT9, GP or Not Fault Output
11	+24 VDC Control Power
12	Control Power Rtn (Ground, Common)
13	Encoder A+ Input

PIN	DESCRIPTION
14	Encoder A- input
15	Encoder B+ input
16	Encoder B- input
17	CAN High (also on 7W2)
18	CAN Low (also on 7W2)
19	RS-485 B (COM CH 1)
20	RS-485 A (COM CH 1)
21	n.c.
22	n.c.
23	USB +5 V Bus
24	USB D+
25	USB D-
26	Ground, Common

### NOTES:

#### I/O TYPE

The Class 6 D-style motor I/O is Sourcing type (PNP).

#### DRIVE ENABLE

The Drive Enable input (pin 8) must be satisfied in order for the motor to turn.

## 24 VOLTS DC POWER

Pin 11 is not a source for 24 VDC power; it is an input only.

- I/O devices must be sourced from an external power supply.
- Loads on specific outputs are allowed (when within the described limits).

## ANALOG INPUTS

- Analog input reading will be saturated at 10 VDC, although the control power level can go up to 24 VDC. In other words, if you place an analog voltage into it, and it went from 0 to 24 VDC, the reading will max out at 10 VDC, even though the input voltage keeps rising.

## DIFFERENTIAL ENCODER

The Differential Encoder inputs use the standard RS-485 chipset:

- If a true differential output TTL encoder is used, just wire A and B signals as labeled.



**CAUTION:** NO differential encoder signals higher than 5V TTL should be used!

## RS-485

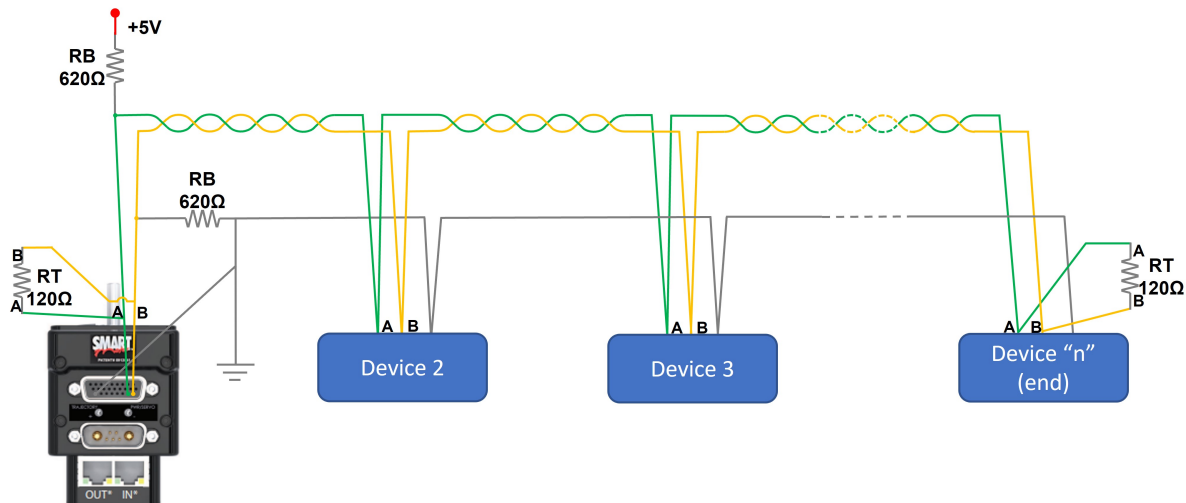

**Note:** The 620 ohm biasing resistors are not needed in most cases but recommended if there are communication problems.

## Class 6 D-Style HD26 Cable Connector (PN: CBLHD26-ASM)

Part CBLHD26-ASM is available so that users can construct their own interface cable for the Class 6 D-style SmartMotor. The connector (with customer-supplied cable) attaches to the HD26 D-sub connector on the motor. The figure and table show the PCB connection points for the cable.

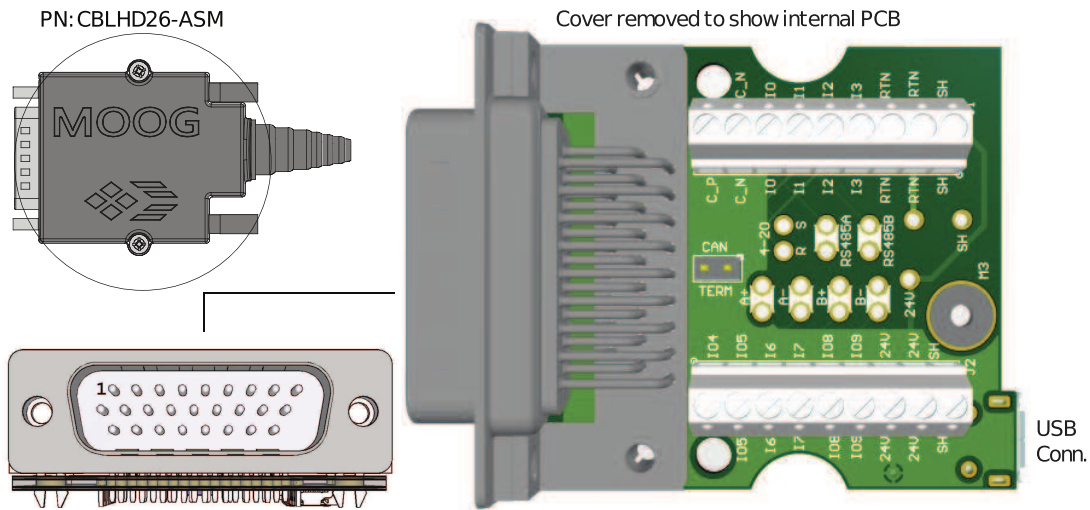

Pin	PCB	AWG	HD26 Connector (24 V Sourcing I/ O)	Specifications:	Notes:
1	I0		IN0 GP, also Analog Input		<b>For Inputs:</b> 9 Configurable and 1 Dedicated Low Lvl Thld: 3.6 V Max High Lvl Thld: 6.0 V Min Analog Input Scale: 10 V FS Inp Impedance >10 Kohm
2	I1		IN1 GP, also Analog Input		
3	I2		IN2 Positive Limit or GP		
4	I3		IN3 Negative Limit or GP		
5	IO4	26	IN/OUT4 GP or Ext. Enc. Index Capture		<b>For Outputs:</b> Do not exceed 200 mAmps source each or 400 mAmps combined
6	IO5		IN/OUT5 GP or Int. Enc. Index Capture		
7	I6		IN6 GP, G Command or Homing Input		<b>For Outputs:</b> Do not exceed 200 mAmps source each or 400 mAmps combined
8	I7		IN7 Drive Enable Input (Dedicated)		
9	IO8		IN/OUT8 GP or Brake Line Output		Also supplies I/O; do not exceed 32 V max
10	IO9		IN/OUT9 GP or Not Fault Output		
11	24V	18	+24 VDC Control Power	+24 V logic I/O; range 18 - 32 V Max	Nonisolated
12	RTN		Control Power Return (Ground, Common)	Ground Reference	
13	A+	26	Encoder A+ Input	1.5 MHz max as Enc or Step input	
14	A-		Encoder A- Input		
15	B+		Encoder B+ Input		
16	B-		Encoder B- Input		
17	C_P	18	CAN High (also on 7W2)	1 Mbit/sec Max	Redundant to 7W2 connector
18	C_N		CAN Low (also on 7W2)		
19	RS485B	26	RS-485 B (COM CH 1)	115.2 KBaud Max	
20	RS485A		RS-485 A (COM CH 1)		
21	—	—			
22	—	—			
23	—	—	USB +5 V Bus		For the USB connector on PCB; used to program from SMI, not recommended for running the motor
24	—	—	USB D+		
25	—	—	USB D-		
26	—	—	Ground, Common		
	RTN		Ground, Common		Additional ground points
	SH		Shield		
	CAN TERM		Jumper - CAN 120 Ohm Term if start/end CAN node		ON =terminated

**NOTE:** All wiring should be twisted pairs unless otherwise noted. Cable should be shielded with spiral wrap aluminumized tape and a .5 mm<sup>2</sup> drain wire of stranded tinned copper. Consult the factory for the more information.

**CAUTION:** DO NOT exceed the specified voltage limits, as this may cause immediate damage to the internal electronics, which will void the warranty.

**CAUTION:** Pins 11 and 12 are intended as an input for control/IO power only. DO NOT attempt to use those pins for main servo-drive power, as this may result in immediate damage to the electronics, which will void the warranty.

**NOTE:** All specifications are subject to change without notice. Consult the factory for the latest information.

## Other Class 6 D-Style Changes

This chapter provides information on getting started with your SmartMotor.

<b>Batteryless Absolute Multiturn Encoder</b> .....	<b>64</b>
Absolute Encoder Control Commands .....	64
<b>EOBK(IO) Command Limitations</b> .....	<b>64</b>
<b>EOFT(IO) Command Limitations</b> .....	<b>64</b>
<b>Ethernet Error, Status Word 2 Bit 6</b> .....	<b>64</b>
<b>I/O Control Details</b> .....	<b>65</b>
I/O Control Examples .....	66
<b>Scale Factor Calculation - Sample Rates</b> .....	<b>66</b>
<b>Commands for Class 6</b> .....	<b>67</b>
<b>Commands That Have Changed</b> .....	<b>68</b>
<b>Commands Not Supported</b> .....	<b>68</b>
<b>Commands Supporting the DS2020 Combitronic System</b> .....	<b>68</b>
<b>Features not Available in Class 6 D-Style</b> .....	<b>68</b>

## Batteryless Absolute Multiturn Encoder

The batteryless absolute multiturn encoder is a standard feature on every Class 6 D-style SmartMotor. It is a magnetic absolute multiturn encoder that requires NO backup battery. Its internal circuitry allows the motor to retain the absolute encoder position and allows continued multiturn position tracking when main power is removed from the motor. This provides the benefits of no rehoming and minimized downtime when main power is removed due to an emergency stop, power outage or other cause.

### Absolute Encoder Control Commands

This section describes the batteryless absolute multiturn encoder control commands that are available for the Class 6 D-style SmartMotor. For more details on these commands, see the *SmartMotor™ Developer's Guide*.

**CAUTION:** Use of the O= or OSH= command will confuse the absolute position information. Therefore, do not use these commands. Instead, use the ENCCTL command (described in this section).

**ENCCTL(-1,x)** removes the effect of the ENCCTL(0,x) command – the PA offset is then set as shipped from factory.

x can be any value.

**ENCCTL(0,x)** sets the absolute position to x, offset is nonvolatile and maintained in the SmartMotor's EEPROM memory. At power-up, the motor's firmware will adjust absolute position with offset.

0 is the command; x is the desired position at the time the instruction is executed and is a signed 32-bit integer.

**ENCCTL(11,x)** selection of encoder resolution relative to 12-bit (4096 counts per revolution). Positive value increases resolution as a bit shift by that value; negative value decreases resolution as a bit shift by that value.

x can be from -2 to 2.

### EOBK(IO) Command Limitations

The EOBK(IO) command configures the specified SmartMotor output to control an external brake. However, only output 8 works for the Class 6 D-style SmartMotor. Therefore, the valid EOBK(IO) values are:

- EOBK(8) to enable
- EOBK(-1) to disable

### EOFT(IO) Command Limitations

The EOFT(IO) command configures the specified SmartMotor output to the fault indication. However, only output 9 works for the Class 6 D-style SmartMotor. Therefore, the valid EOFT(IO) values are:

- EOFT(9) to enable
- EOFT(-1) to disable

### Ethernet Error, Status Word 2 Bit 6

The intent of Status Word 2 bit 6 is to inform the user that one or more errors has occurred through the Ethernet interface. To determine the specific error that has occurred, consult the RETH command

description in the corresponding fieldbus guide.

## **I/O Control Details**

The SmartMotor fieldbus guides describe the details of accessing I/O for each communication protocol. The *SmartMotor™ Developer's Guide* also describes I/O control details.

In a local program or serial command, the OR, OS and OUT commands are the same as Class 5. For details, see the *SmartMotor™ Developer's Guide*.

For the Class 6 D-style SmartMotor, it is important to note which are inputs, which are outputs, and which have special functions. For those details, refer to the next table.

Logical I/O Number	Input or Output	Possible (Selectable) Functions	Default Operation
0	Input only	General purpose, discrete or analog	General purpose
1	Input only	General purpose, discrete or analog	General purpose
2	Input only	Positive limit, or general purpose	Positive limit
3	Input only	Negative limit, or general purpose	Negative limit
4	Input/Output	General purpose, or index capture for external encoder	General purpose
5	Input/Output	General purpose, or index capture for internal encoder	General purpose
6	Input only	General purpose, G command, or homing input	General purpose
7	Input only	Drive enable	Drive enable
8	Input/Output	General purpose or brake output	General purpose
9	Input/Output	General purpose or not fault output	General purpose

## I/O Control Examples

To read inputs:

```
x=IN(W,0,15) 'Reads inputs 0,1,2,3 as bitfield stored into variable x
EIGN(2)      'Disables positive limit, makes a general-purpose input
EIGN(3)      'Disables negative limit, makes a general-purpose input
EILP         'Re-enables positive limit
RIN(3)       'Reads input 3
```

## Scale Factor Calculation - Sample Rates

The sample rate for Class 6 SmartMotors is fixed at 16,000 Hz (16 kHz).

## Commands for Class 6

When transitioning from Class 5 to Class 6 motors, be aware that the commands in this section were added for the Class 6 SmartMotor.

**NOTE:** These commands are *not* available for the Class 5 SmartMotor.

**EOFT:** Configure a specified output for the fault indication.

**GROUP(function,value):** Configure group addressing settings of the Combitronic over Ethernet (UDP) communications.

**IDENT=, RIDENT, x=IDENT:** Set the IDENT value which is useful for user programs to detect which axis they are. Report, use in expression, or assign the value of IDENT to a user variable.

**IPCTL(action,"string"):** Sets IP address, Mask, or Gateway:  
action= 0, set IP address; 1, set Mask; 2, set Gateway;  
"string": formatted as an IP address and entered as a string;  
e.g., IPCTL(0,"192.168.0.10") sets IP address to 192.168.0.10

**PRINT0:** Explicitly outputs to the COM 0 serial port.

**PRINT8:** Explicitly outputs to the USB port.

**RGROUP(function):** Report group addressing setting of the Combitronic over Ethernet (UDP) communications.

**RSP5:** Reports network interface card firmware version.

**RUSB(arg), x=USB(arg):** Report the value of the specified USB status word (specified by arg) or assign it to a variable.

**RUSB, x=USB:** Report the value of USB status word 0 or assign it to a variable.

**SNAME("string"):** Sets a unique PROFINET station name. See the *Class 6 SmartMotor™ PROFINET Guide*.

For details on these commands, see the *SmartMotor™ Developer's Guide*.

These Industrial Ethernet (IE) commands were added for the Class 6 SmartMotor:

**NOTE:** These commands are *not* available for the Class 5 SmartMotor.

**RETH(arg), x=ETH(arg):** Assign result to a variable or report errors and certain status information for the EtherCAT or PROFINET bus. See the corresponding fieldbus manual for arg values.

**ETHCTL(action,value):** Controls network features. See the corresponding fieldbus manual for details.

For details on these commands, see the *Class 6 SmartMotor EtherCAT Guide* or the *Class 6 SmartMotor™ PROFINET Guide*.

## Commands That Have Changed

These commands have been modified for the Class 6 D-Style SmartMotor:

**ENCCTL:** Parameters were added for control of the Class 6 D-style batteryless absolute multiturn encoder. For more information, see Batteryless Absolute Multiturn Encoder on page 64.

**PRINT:** Corresponds with the value of **STDOUT**, which is 0 (RS-232 port) by default. Note that this behavior is different than in Class 5 motors.

**STDOUT=0:** (Default) Sets internal report commands to the COM 0/RS-232 port.

For details on these commands, see the *SmartMotor™ Developer's Guide*.

## Commands Not Supported

These commands are not supported in the Class 6 D-style SmartMotor:

ENCD, EOIDX, MDH, MDHV, MDT, OC, OF, PID, SCALEA, SCALEP, SCALEV

## Commands Supporting the DS2020 Combitronic System

Note that the Class 6 D-style motors support the DS2020 Combitronic system. Therefore, any commands specific to that product are available on these motors.

For details on the commands for the DS2020 Combitronic system, see the topic "Commands for DS2020 Combitronic" in the *SmartMotor™ Developer's Guide*.

## Features not Available in Class 6 D-Style

These features are not implemented:

- DeviceNet protocol
- PROFIBUS protocol
- I<sup>2</sup>C communications
- AD1 option

## Troubleshooting

This section provides troubleshooting information for common problems. For additional support resources, see: <http://www.animatics.com/support.html>.

Issue	Cause	Solution
<b>Communication and Control Issues</b>		
Motor does not communicate with SMI.	Transmit, receive or ground pins are not connected correctly.	Ensure that transmit, receive and ground are all connected properly to the host PC.
	Motor program is stuck in a continuous loop or is disabling communications.	To prevent the program from running on power up, use the Communications Lockup Wizard located on the SMI software Communications menu.
Motor disconnects from SMI sporadically.	COM port buffer settings are too high.	Adjust the COM port buffer settings to their lowest values. This is done in the Windows Device Manager> Advanced Settings dialog box for the associated COM port driver.
	Poor connection on cable from motor to PC.	Check the cable connections and/or replace it.
	Power supply unit (PSU) brownout.	PSU may be undersized for the application, which causes it to brown-out during motion. Make moves less aggressive, increase PSU size or change to a linear unregulated power supply.
Motor stops communicating after power reset, requires redetection.	Motor does not have its address set in the user program. NOTE: Serial addresses are lost when motor power is off or reset.	Use the SADDR or ADDR= command within the program to set the motor address.
Motor doesn't turn.	Faults not cleared and/or drive enable not satisfied.	Clear faults (see Checking and Clearing the Status Bits on page 51). Satisfy the drive enable input (see Drive Enable Input on page 33).
No CAN bus signal on the flying lead cable	HD26 cable DIP switches are set incorrectly.	Check the cable DIP switch settings. For CAN bus pass-thru, switches 1 & 2 must be ON, switches 3 & 4 must be OFF; reverse those settings for CAN bus termination.
<b>Common Faults</b>		
Bus voltage fault.	Bus voltage is too high for operation.	Check servo bus voltage. Check for excessive regenerative energy from motor due to no/insufficient shunt resistor.
	Bus voltage is too low for operation.	If motor uses the dual-power configuration (separate drive and control power supplies), ensure that both power supplies are connected and are sized correctly for the motor.
Overcurrent occurred.	Motor intermittently drew more than its rated level of current. Does not cease motion.	Consider making motion less abrupt with softer tuning parameters or lower acceleration profiles.
Excessive temperature fault.	Motor has exceeded internal PCB temperature limit of 85°C. Motor will remain unresponsive until it cools down below 80°C.	Motor may be undersized or ambient temperature is too high. Check motor sizing for the application in terms of continuous rating. Consider adding heat sinks or forced air cooling to the system.
Excessive position error.	The motor's commanded position and actual position differ by more than the user-supplied error limit.	Increase error limit, decrease load or make movement less aggressive. Also, ensure you are not voltage limited for the torque at speed required. If running from less than 48 VDC, check ratings for lower bus voltages and ensure the motor is within required torque capacity.
Motor faults on position error only after a certain amount of time.	Motor sized incorrectly.	Check motor sizing for the application in terms of continuous rating. Also, ensure you are not voltage limited for the torque at speed required. If running from less than 48 VDC, check ratings for lower bus voltages and ensure the motor is within required torque capacity.
Motor is not accurately corresponding to trajectory.		

For Further Information...

Issue	Cause	Solution
<b>Programming and SMI Issues</b>		
Several commands not recognized during compiling.	Compiler default firmware version set incorrectly.	Use the Compiler default firmware version option in the SMI software Compile menu to select a default firmware version closest to the motor's firmware version. In the SMI software, view the motor's firmware version by right-clicking the motor and selecting Motor Properties.

## For Further Information...

Now that your SmartMotor is installed and operating, the next step is to learn about its features, commands and programming in order to create a useful application.

Information on SMI software features, SmartMotor programming, communications, motion control and more is provided in the *SmartMotor™ Developer's Guide*. That guide also includes a complete SmartMotor command reference, and an Appendix of other related topics that are useful during application development.

# TAKE A CLOSER LOOK

Moog Animatics, a sub-brand of Moog Inc. since 2011, is a global leader in integrated automation solutions. With over 30 years of experience in the motion control industry, the company has U.S. operations and international offices as well as a network of Automation Solution Providers worldwide.

Moog Animatics  
1995 NC Hwy 141  
Murphy, NC 28906  
United States

Email: [animatics\\_sales@moog.com](mailto:animatics_sales@moog.com)

For Animatics product information, visit [www.animatics.com](http://www.animatics.com)

For more information or to find the office nearest you, email [animatics\\_sales@moog.com](mailto:animatics_sales@moog.com)

Moog is a registered trademark of Moog Inc. and its subsidiaries.  
All trademarks as indicated herein are the property of Moog Inc. and its subsidiaries.  
©2015-2026 Moog Inc. All rights reserved. All changes are reserved.

Moog Animatics Class 6 D-Style SmartMotor™ Installation and Startup Guide,  
Rev. G, February 2026, SC80100022-001

[www.animatics.com](http://www.animatics.com)

